



Performance Requirements for Large Loads Connected to the LIPA System

Overview Presentation



Acknowledgements

PSEG Long Island, on behalf of the Long Island Power Authority, has retained electric industry reliability experts to recommend potential local reliability requirements to preserve and enhance the reliability of LIPA's electric system to mitigate potential reliability risks caused by large swings or problematic oscillations in power usage by Large Loads that connect to LIPA's transmission system consistent with industry practices including NERC and Good Utility Practice.

We would like to acknowledge the following specialized technical consultants in developing these requirements and presentation:

Telos Energy - Matthew Richwine

Telos Energy - Nicholas Oberski

WESC - Reigh Walling

Overview – Large Load Technical Requirements

Overall Approach

- Start with “Performance Requirements For Transmission-Connected Non-Synchronous Resources”
- Adjust/drop what is not applicable, add what is uniquely applicable for large load interconnections

Major Sections (Significant differences from the NSR for Generation)

- Scope of Applicability
- Voltage Ride-Through
- Active Power Variations
- Small Signal Stability
- Model Requirements
- Verification, Monitoring, and Protection



What is In Scope?

- $\geq 20\text{MW}$ **Gross** Load (not net load)
- Transmission or Distribution Connected
- Exceptions for 'campuses' with diversified loads
- Includes aggregation of multiple “synchronously operated” loads

Figure 3: Thresholds applied to define a large load in the US

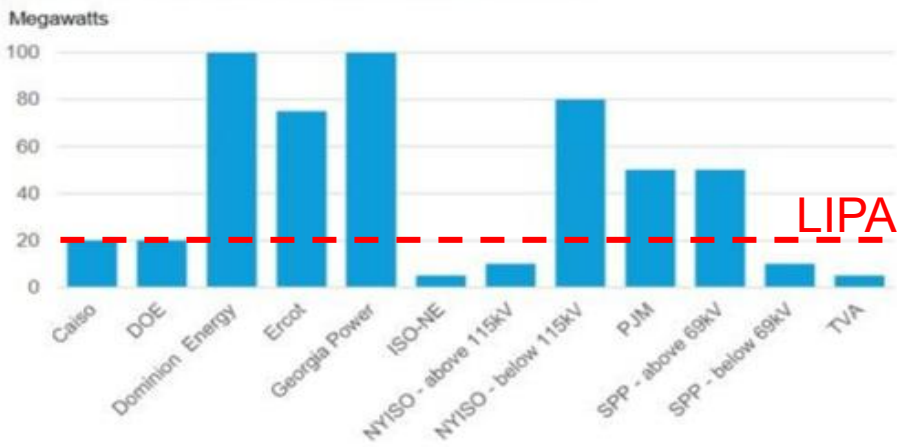

Source: BloombergNEF, company reports, press releases. Note: Caiso is California ISO, ISO is independent system operator, DOE is department of energy, Ercot is Electric Reliability Council of Texas, NYISO is New York ISO, ISO-NE is ISO New England, PJM is PJM interconnection, SPP is Southwest Power Pool, TVA is Tennessee Valley Authority, kV is kilovolt.

Ex 1: Load $\geq 20\text{MW}$; **In-Scope**

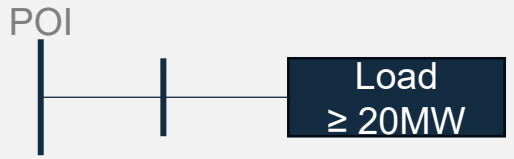

Ex 3: Diversified Load $\geq 20\text{MW}$,
Non-diversified $< 20\text{MW}$;
May be exempted

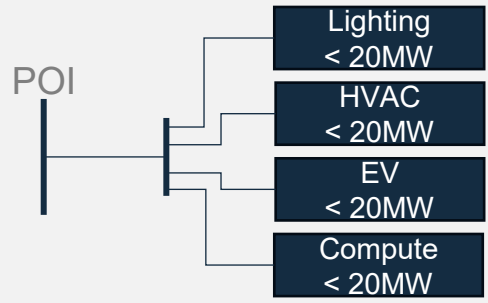

Ex 2: Gross Load $\geq 20\text{MW}$,
Net Load $< 20\text{MW}$; **In-Scope**

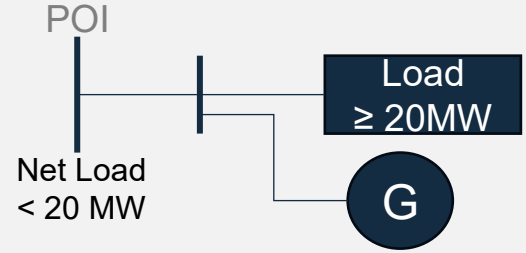

Ex 4: Aggregate, Synchronized
Load $\geq 20\text{MW}$,
Individual load $< 20\text{MW}$;
In-Scope

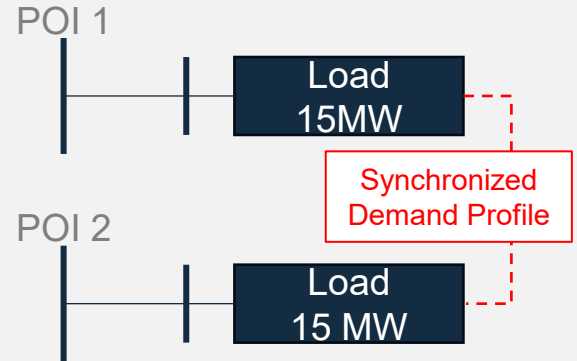

Voltage Ride-Through, Summarized

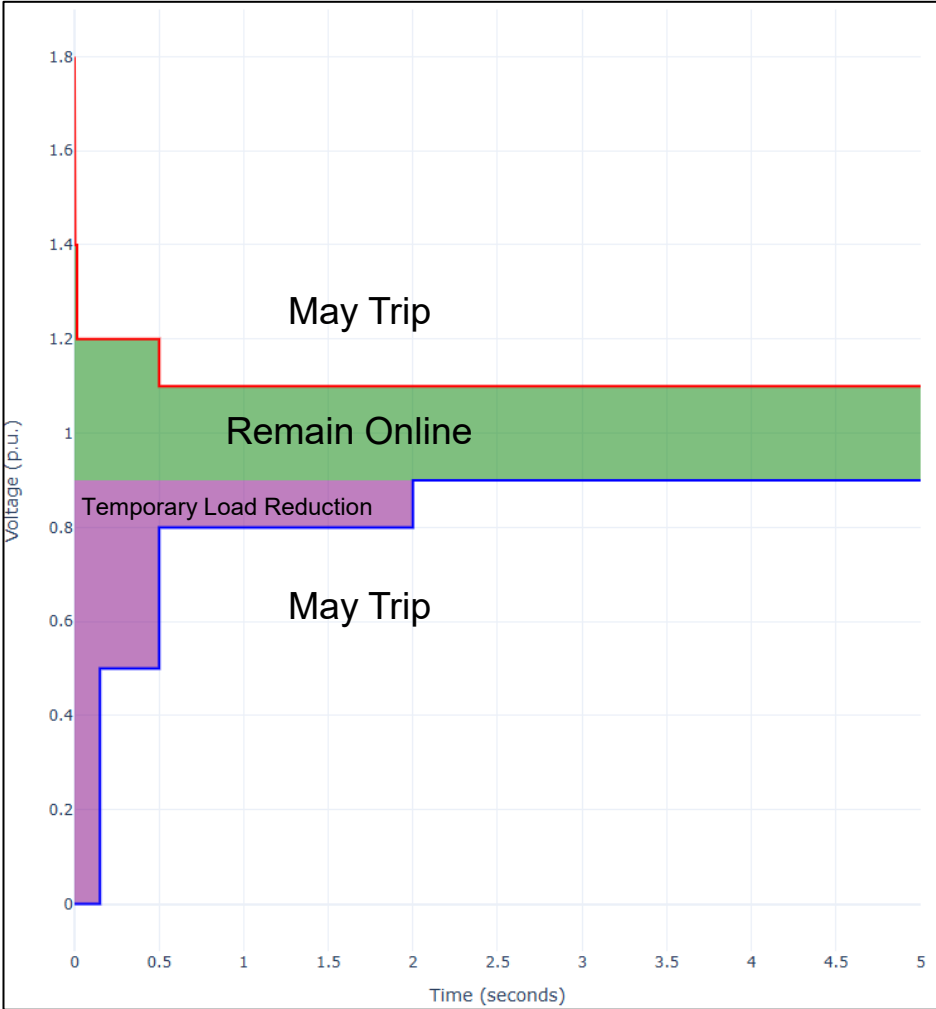

During low voltages (< 0.90pu), power consumption may temporarily drop, but power must resume 90% pre-disturbance levels within 1.0 seconds of voltage recovering to > 0.90 pu

*Proposed Requirements were developed with consideration of existing requirements by ERCOT, ATC, IEEE 2800, etc.

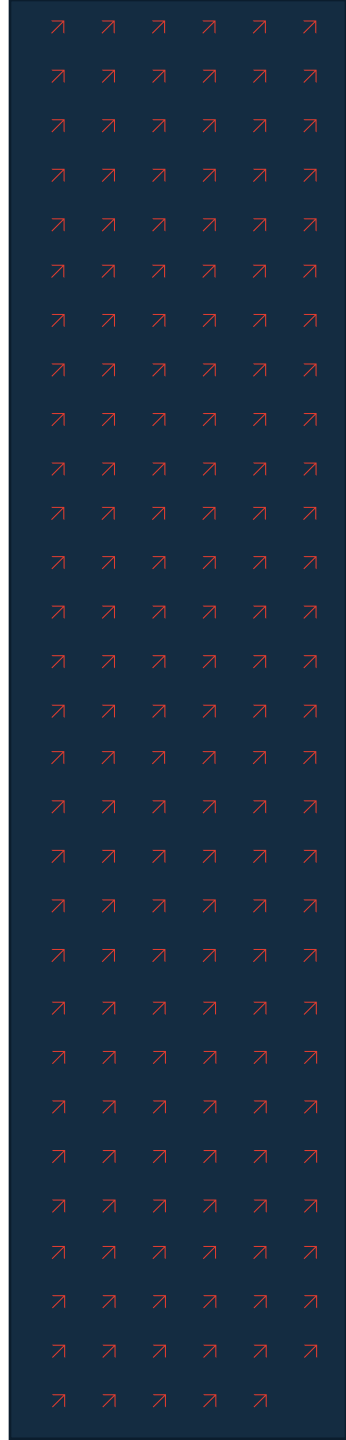

Active Power Variation Risk

Load

Consider if one of the loads had power demand like this:

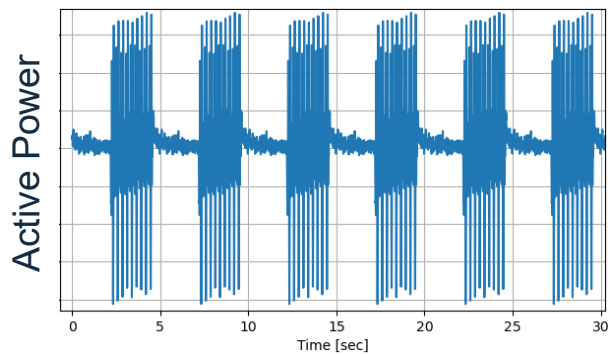

Network

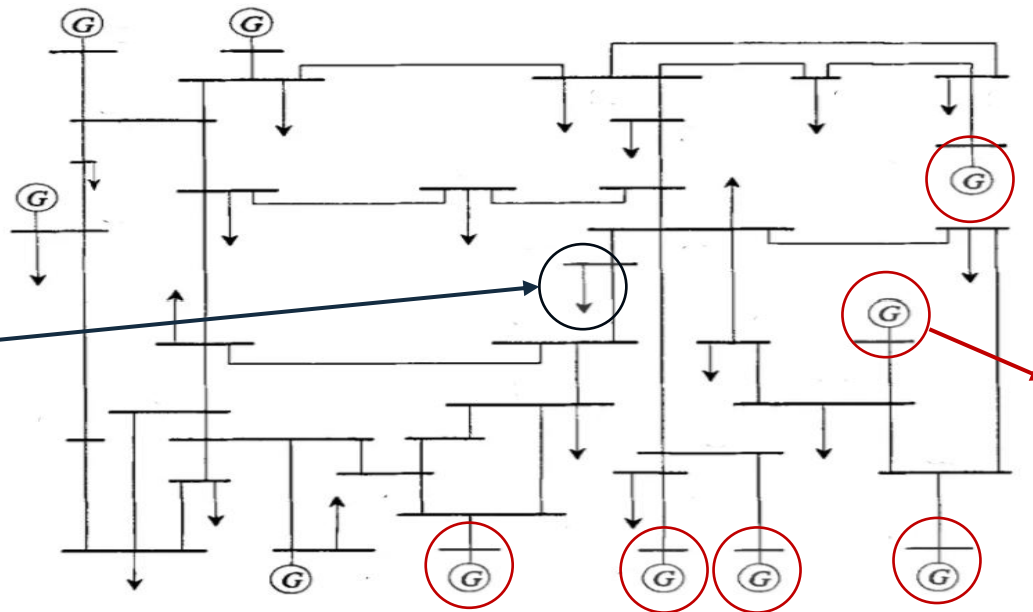

Synchronous Machinery

Power variation could cause significant alternating torques on the shaft(s) of nearby synchronous generator(s)

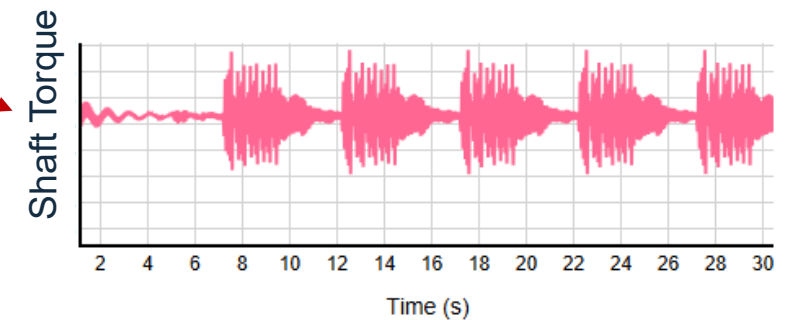

The Risk:

- Excessive alternating torques on a drivetrain will cause consumption of shaft life
- If undetected, it may consume all design life resulting in a premature, catastrophic failure of the shaft
- *Other potential impact to inverter-based facilities, in addition to Torsional Stress

Mohave Shaft Failure due to Excessive Torsional Stress



Active Power Variation Requirements

Approach:

- Set conservative, generalized limits
- Allow exceptions for special studies
- Acknowledge that location of interconnection matters, but it's hard to generalize requirements by location

Why this approach?

- Projects that meet the limits can move relatively quickly through the process (by avoiding detailed study)
- Smaller projects would likely have an easier time meeting fixed MW requirements, and may be able to move faster
- Large projects with significant pulsing power may not meet conservative requirements. These will either need mitigation or detailed study work to show that risks are sufficiently low without mitigations

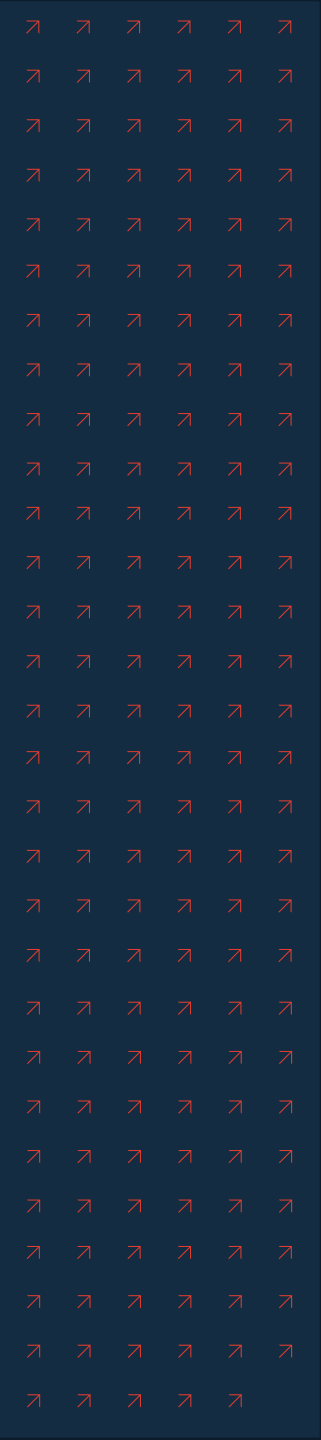

Active Power Variation

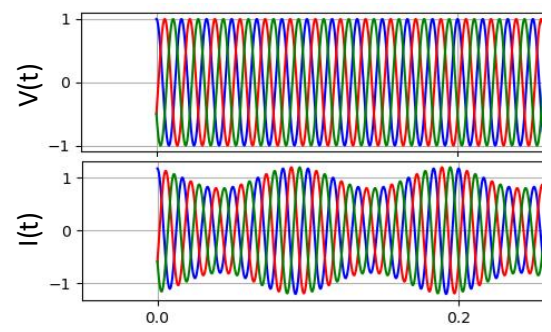
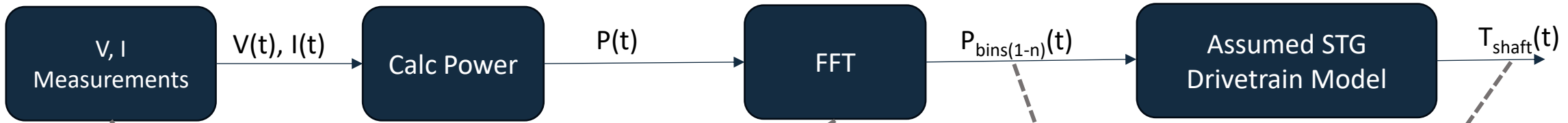

Spectral Power Density, Snapshot in Time

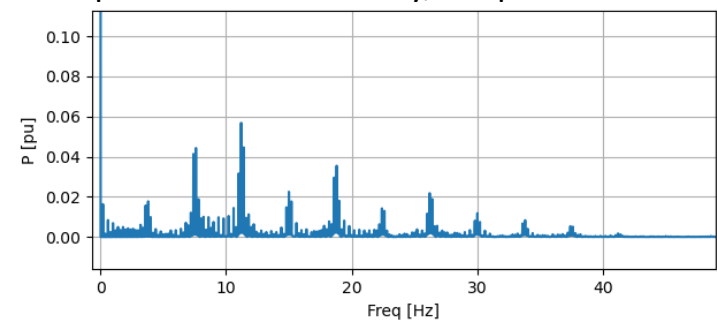

Example STG Gen Shaft Torques

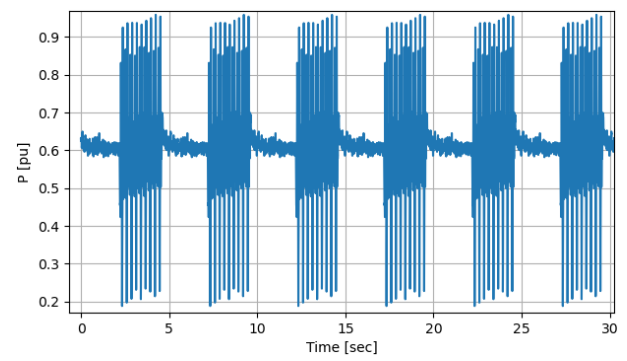
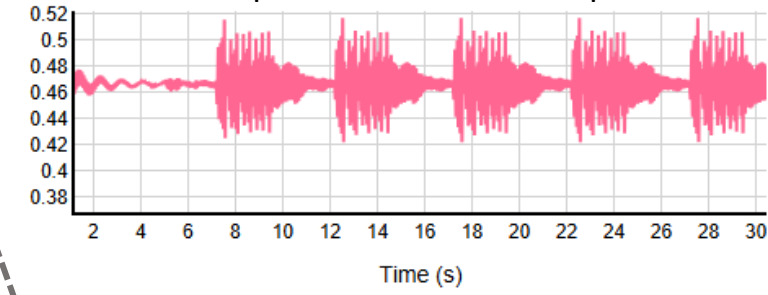

Spectral Power Density, Rolling Window in Time

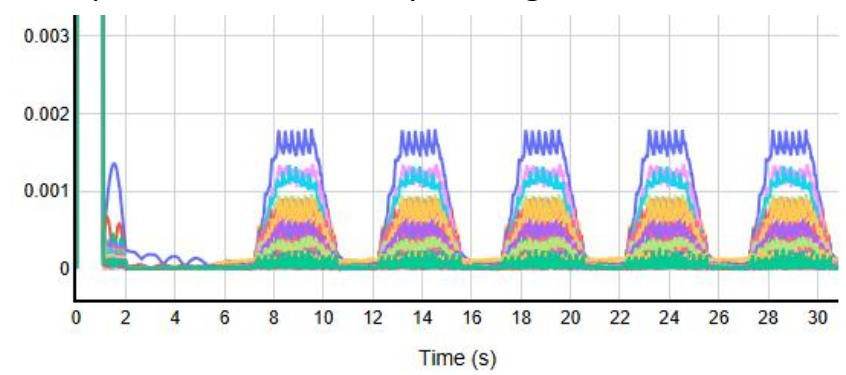

Active Power Variation Impact

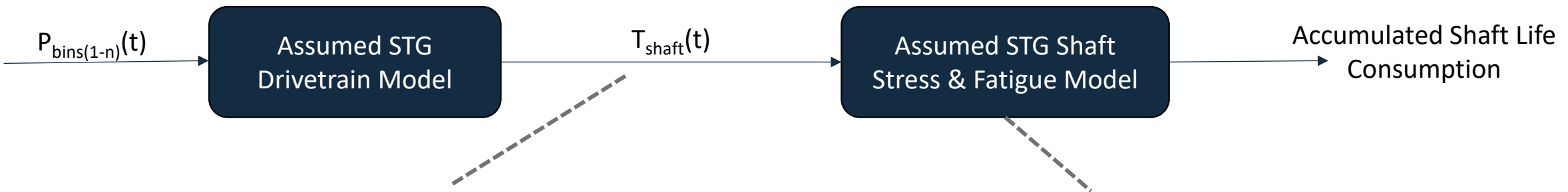

Example STG Gen Shaft Torques

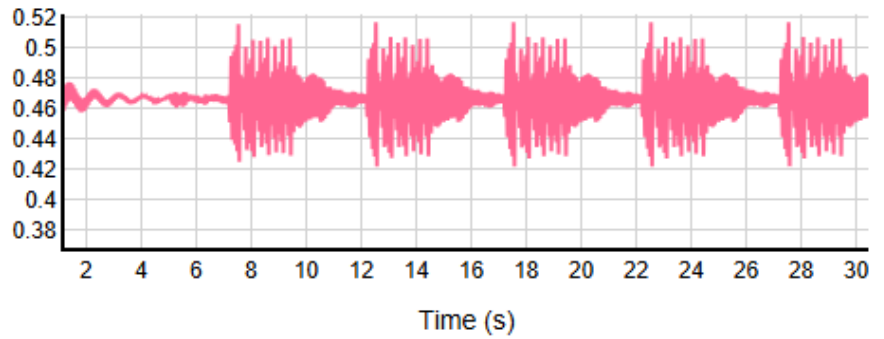

S-N Curve, Conservative Assumptions

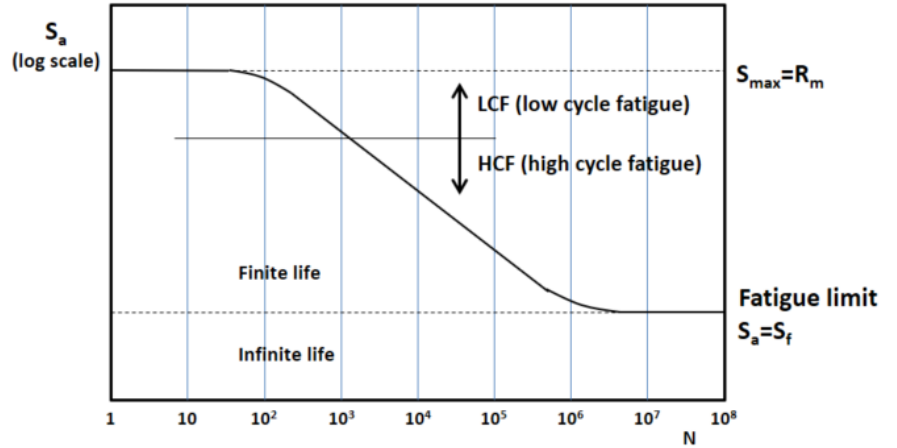

Active Power Variation Requirement

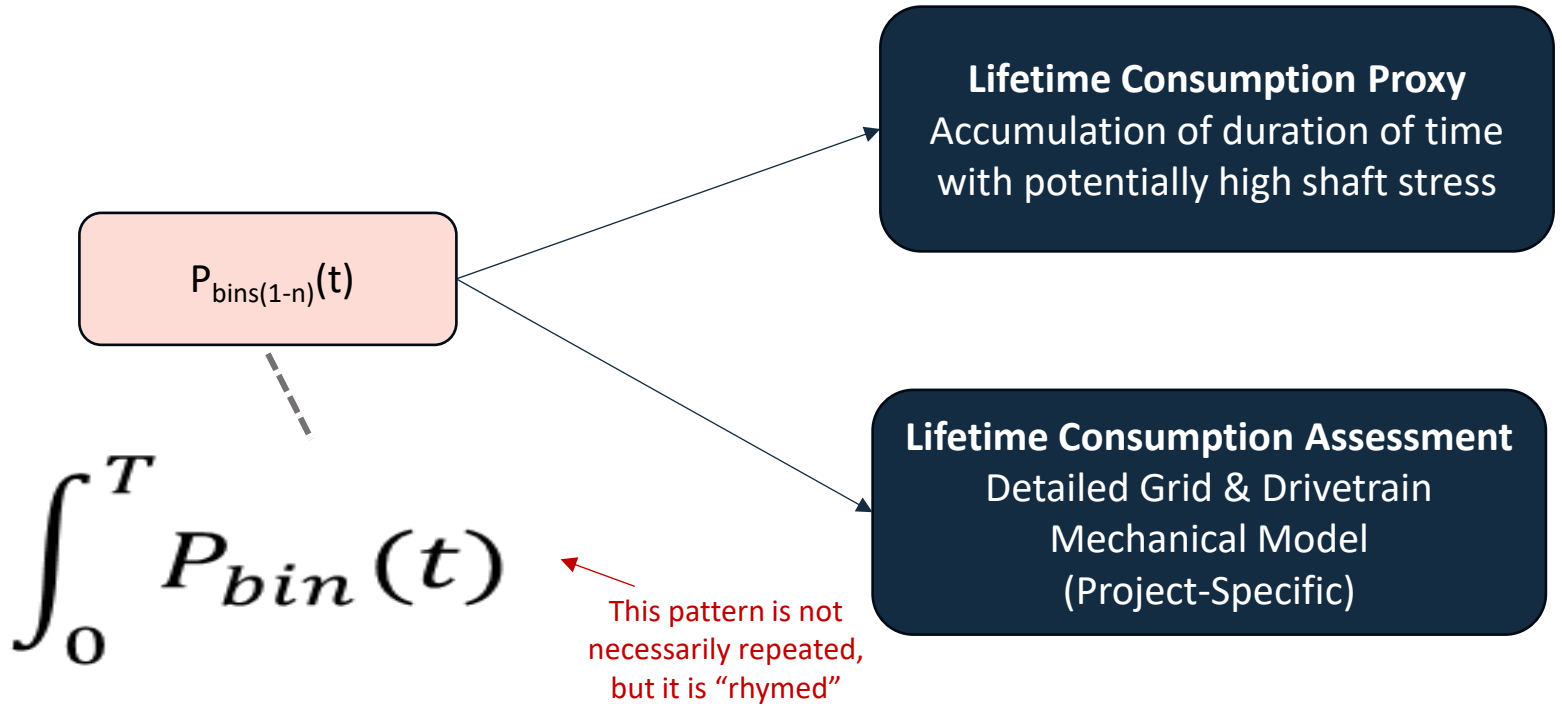

$\int_0^T P_{bin}(t)$ Set Maximum Limits on the Average Power for each frequency bin

A detailed model with conservative grid assumptions and a typical STG model were used to calibrate limits for requirements

- An Additional Challenge:
- Power profile for some processes (AI DC) is stochastic and always changing in time
 - How to avoid being overly onerous with a requirement for an occasional torque spike (above the endurance stress limit) that does not meaningfully contribute to shaft fatigue?

Active Power Variation Result

Final Requirement:

Established operational limits using conservative system baselines and real-world steam turbine modeling

Frequency Band	Limit	Rolling Window (w) for Calculation
High Subsynchronous (5.0 – 55.0 Hz)	The $P_{0-pk,avg}$ for the sum of any two adjacent frequency bins shall not exceed 3.5 MW _{0-pk,avg}	10 second rolling window
Low Subsynchronous (0.1 – 5.0 Hz)	The $P_{0-pk,avg}$ for the sum of any two adjacent frequency bins shall not exceed 10.0 MW _{0-pk,avg}	60 second rolling window

$$P_{0-pk,avg}(t, bin) = \left(\frac{1}{w}\right) \int_{t-w}^t P_{bin}(t) dt$$

Dynamic Performance – Small Signal Stability

The response of a load (change in power) to a small change in voltage (magnitude and/or angle) can either:

- Reduce the original change in voltage (**increase damping**)
- Exacerbate the original change (**reduce damping**)

Requirement: Do not reduce damping

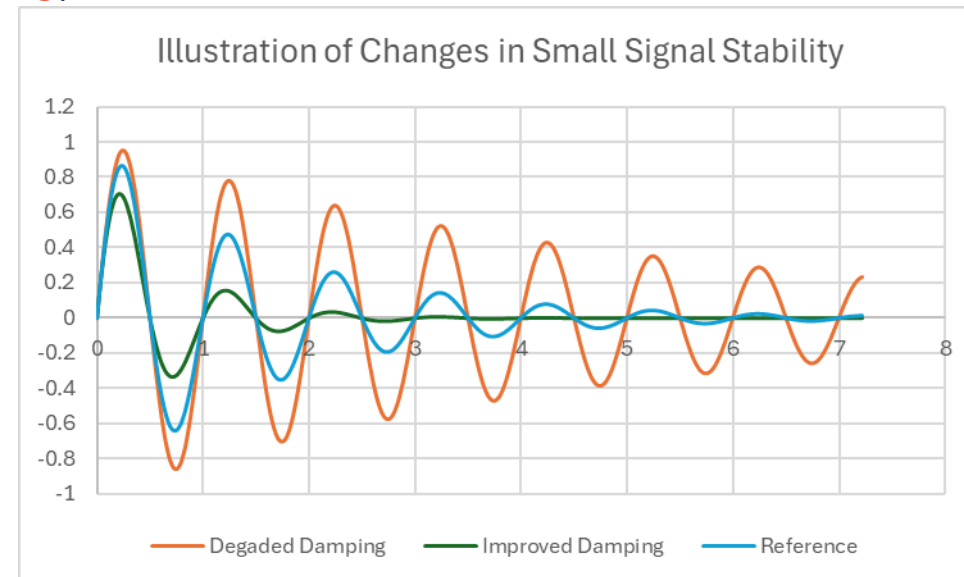
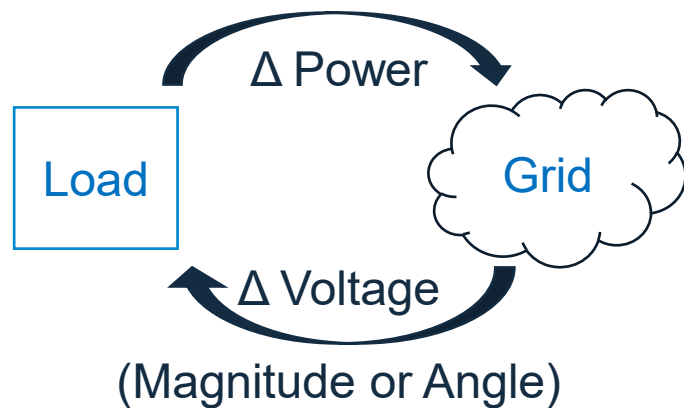

Proposed Model Requirements

Models Required:

- Steady-State (Power Flow)
- Dynamics, Phasor Domain (PSSE)
- Dynamics, EMT (PSCAD)

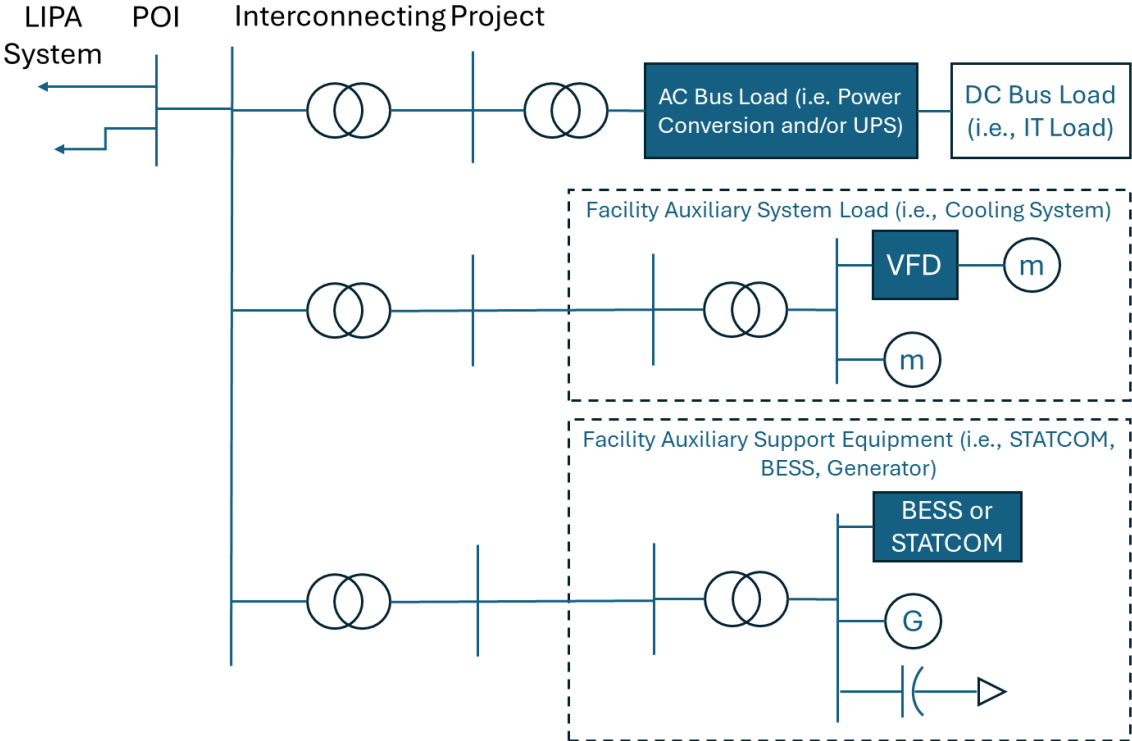

Large Load Equipment	Example Equipment Variants	Phasor Domain Dynamic Model Representation	EMT Model Representation
Facility Major Components	Facility-Specific	Required for all Facility Major Components	Required for all Facility Major Components
DC Bus Load	IT Load: Algorithm-Specific, Software-Driven Load Cycling; Post-Rectification Load	Simplified Representation Is Acceptable	Simplified Representation Is Acceptable
AC Bus Load	Power Electronics - Diode-Front-End or Active-Front-End Rectification	Required, Explicit Representation	Required, Facility-Specific Representation with OEM Models
Facility Auxiliary System Load	Large Motors for Pumps/Fans, which may be VFD-interfaced or line-connected induction motors	Required, Explicit Representation	Required, Facility-Specific Representation with OEM Models
Facility Auxiliary Support Equipment	STATCOMs, Battery Systems, Generation, etc.	Required, Explicit Representation	Required, Facility-Specific Representation with OEM Models

*Additional details on applicability are detailed in the requirement document

Performance Verification & Monitoring

Performance Verification

- Combinations of detailed simulations, laboratory testing, field testing
- Provide data in advance for new power variation profiles

Real-Time Monitoring

- DFR, DDR – Disturbance Recording for Post-Event Analysis
 - DFR – Digital Fault Recorder
 - DDR – Dynamic Data Recorder
- Power Quality (PQ) meter – Continuous monitoring for harmonic distortion

Real-Time Protection

- Active Power Variation Protection Relay – Continuous protection for excessive repetitive variations in active power



Other Sections

- Limitation of Overvoltage
- Transient Reactive Current Demand During Large Disturbances
- Response to Large Voltage Angle Deviations
- Response to Small Voltage Magnitude Deviations
- Active Power Control Response
- Active Power Ramp Rate Limits
- Response to Deviations in Frequency

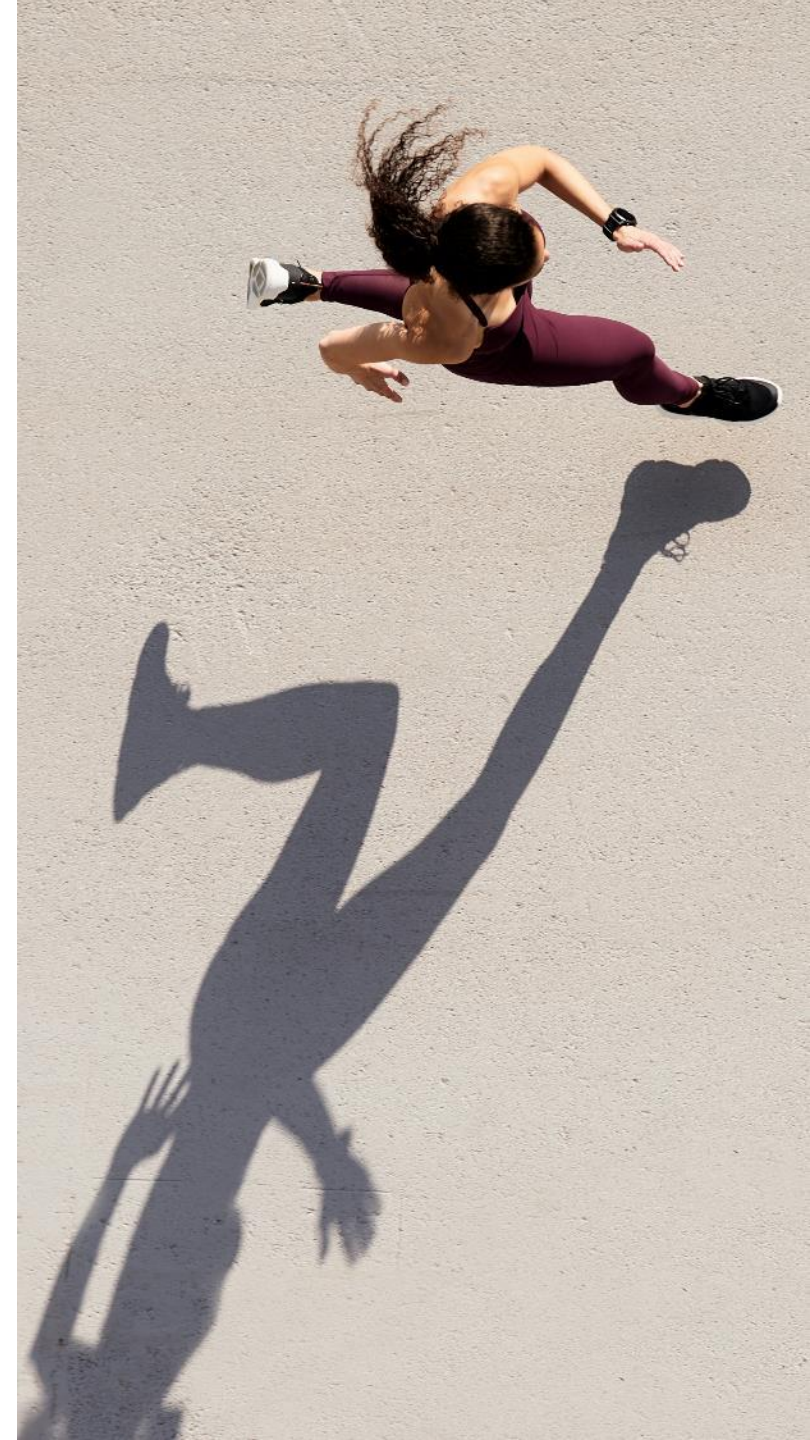



 Thank
you

Dylan Dreisch – Dylan.Dreisch@psegliny.com

Full Criteria Document posted at:

<https://www.psegliny.com/aboutpseglongisland/LegalandRegulatory>



Appendix

Additional References

[AESO Connection Requirements for Transmission-Connected Data Centers, Aug 2025](#)

[ATC Load Interconnection Guide, Revision 15, Aug 22, 2025, Section 1.1](#)

[ATC TO Planning Criteria, v25, Aug 28, 2025, Section 9](#)

[Dominion Facility Interconnection Requirements](#)

[ERCOT Planning Guide 5.5 and 6.2 \(PGRR-085\)](#)

[ERCOT Proposed Large Electrical Load Requirements, December 2025](#)

[IEEE Std. 2800 – Interconnection and Operability of Inverter-Based Resources](#)

[NERC PRC-029 – Frequency and Voltage Ride-Through](#)

[NERC Alert – Large Load Interconnection, September 2025](#)

[NYISO UG-21 – Transmission Expansion and Interconnection Guide](#)

[NYISO UG-28 – Modeling Guideline](#)

[Southern Company Large Load Technical Requirements](#)

