



Non-Synchronous Energy Electronics, LLC

ERCOT AI Data Center Interconnection Solutions;

**Series Connected AC/DC/AC PCS BESS Solutions for;
LVRT, CLR, BYOG, Ancillary Services, Generator Optimization
and 800VDC Solutions**

Alan McDonnell, President, NSEE

May 21, 2026

**NSEE is partnered with Sabre Canada of Calgary and Indrivetec of Zurich
to deliver PCS Projects, in Canada & the USA**

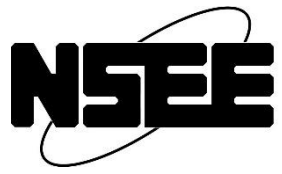

- Sabre Canada, based in Calgary, is the commercial lead on the projects
- Sabre packages the Power Converter Systems, transformers and switchgear at their facility in Calgary



- Indrivetec provides the power converters from their factory in Bulgaria, and engineering and technical support from their head office in Zurich



SWISS engineering

Presentation Description

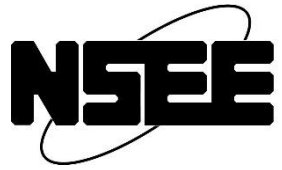

The need for Power Flow Control and Grid Stability while integrating erratic AI loads;

This presentation describes the variety of solutions that NSEE/Sabre/Indrivetec can supply for AI Data Centers to interconnect to the bulk power grid.

NSEE takes a total energy approach to system design, taking into account the needs of each stakeholder, and the realities of reliably feeding and operating such large erratic loads.

With these Series PCS solutions, the modelling requirements for interconnection permitting in markets like ERCOT are much more simple, similar to a standard BESS project

We concur that it should be the burden of a data center developer to include power conditioning systems that will smooth out the load drawn from the grid, such that it appears stable, and can even help support instabilities in the grid caused by others or events.

The following slide shows how erratic an AI Data Center load can be, and then how it can be served by a smooth power feed from the grid

The presentation also shows how a wide variety of storage and on-site generation BYOG assets may be connected, in order to ensure seamless operation of the Data Center, essentially using the Power Conversion Interface as an Uninterruptible Power Supply.

Block Diagram Example – Standard Load Interconnection

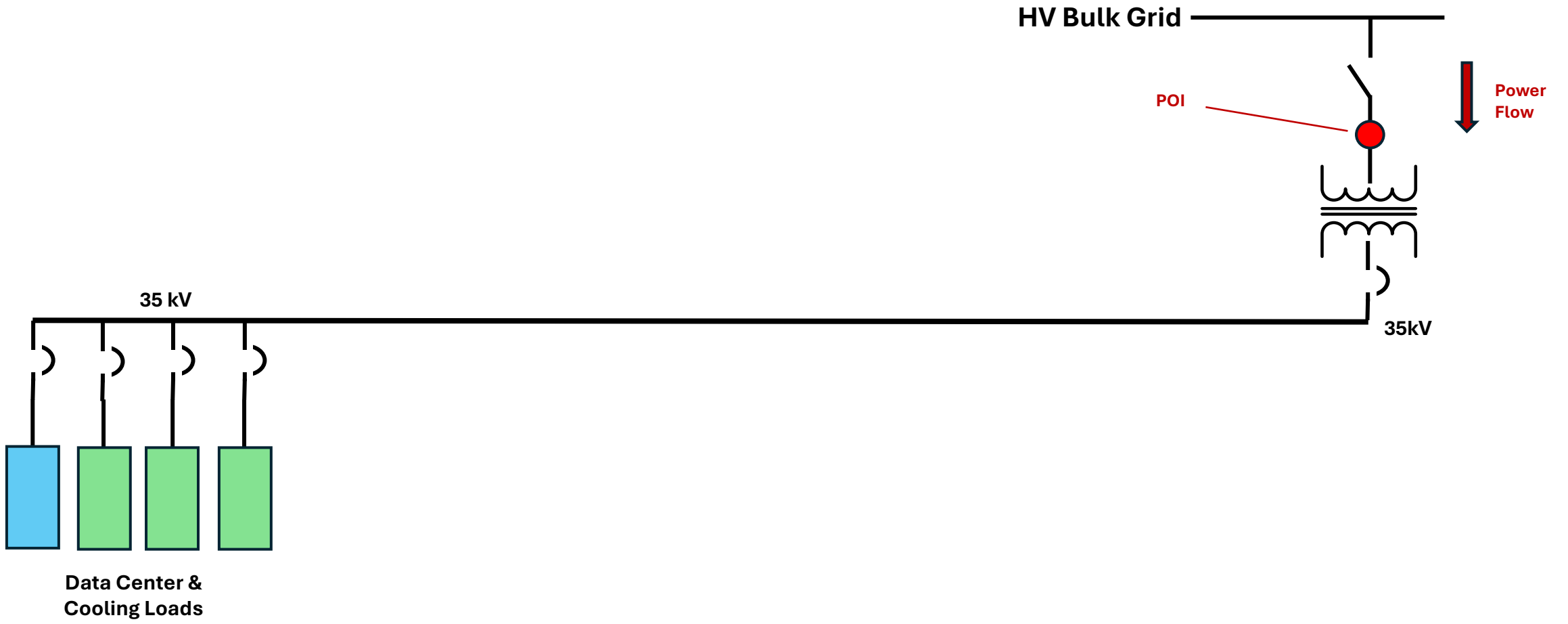
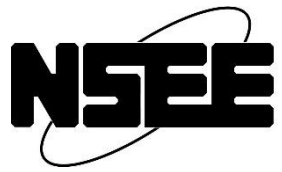

A measured example of an AI Data Center load that needs to be smoothed by the ESS

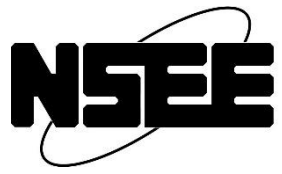

Ultra-Capacitor solutions may be needed when the duty cycle is too great for batteries, or a combination of the two if bulk storage is also required.

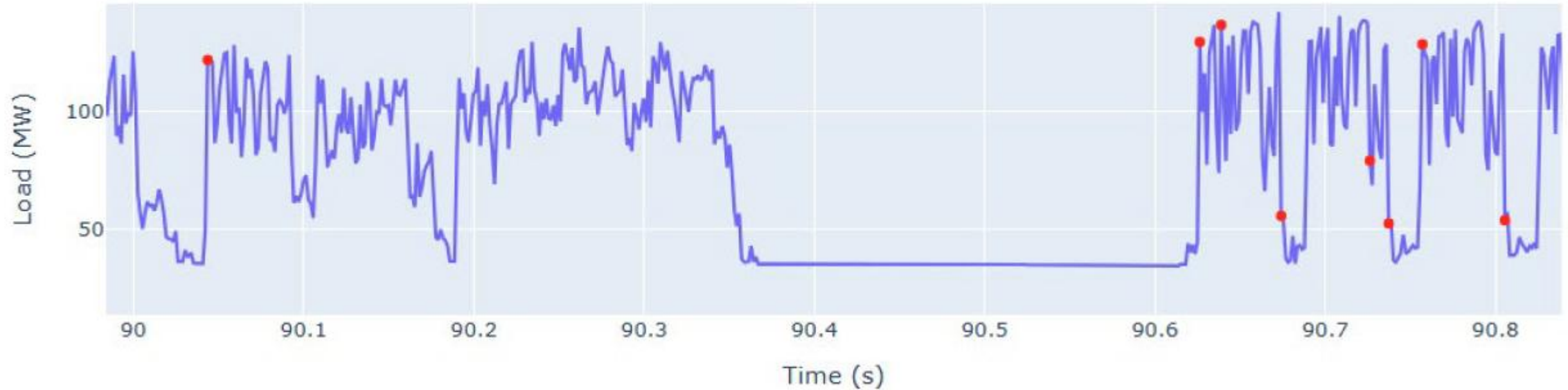

Block Diagram Example – Standard Load Interconnection with Parallel BESS

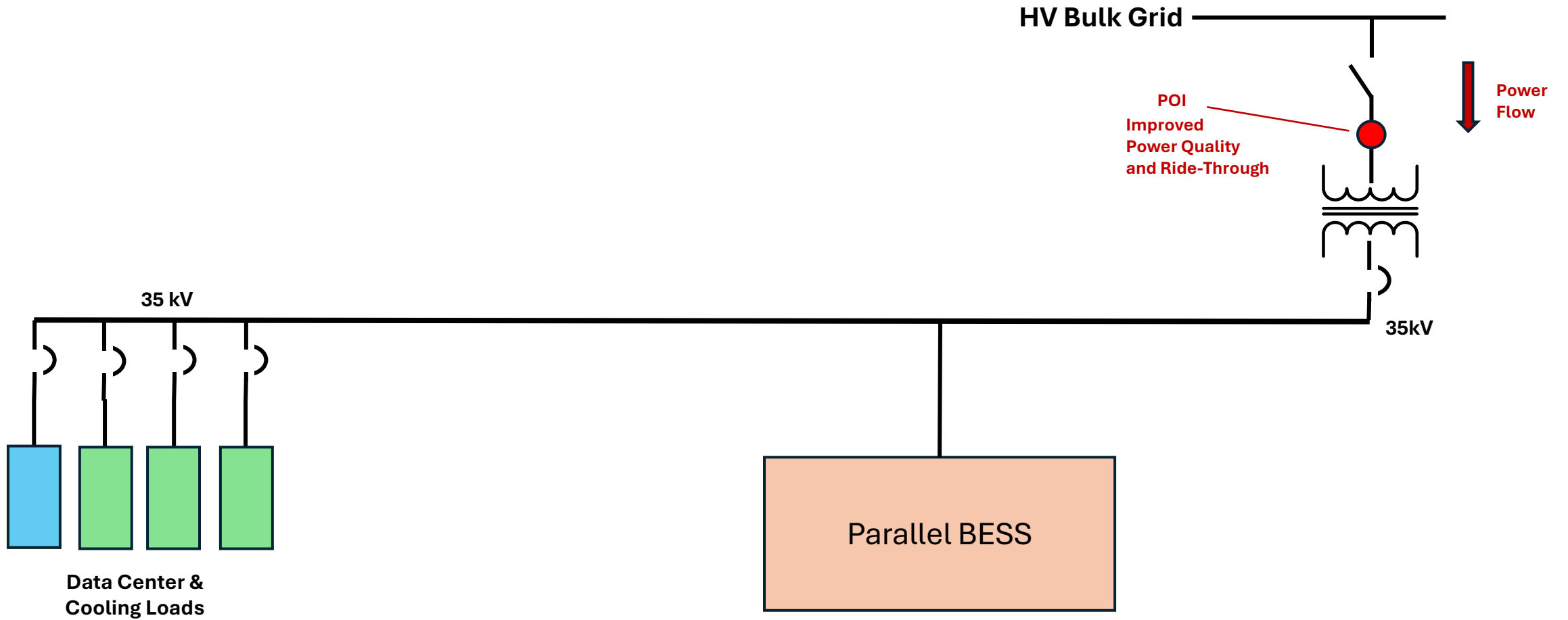

Block Diagram Example – Standard Load Interconnection with Series BESS CLR inherent in design

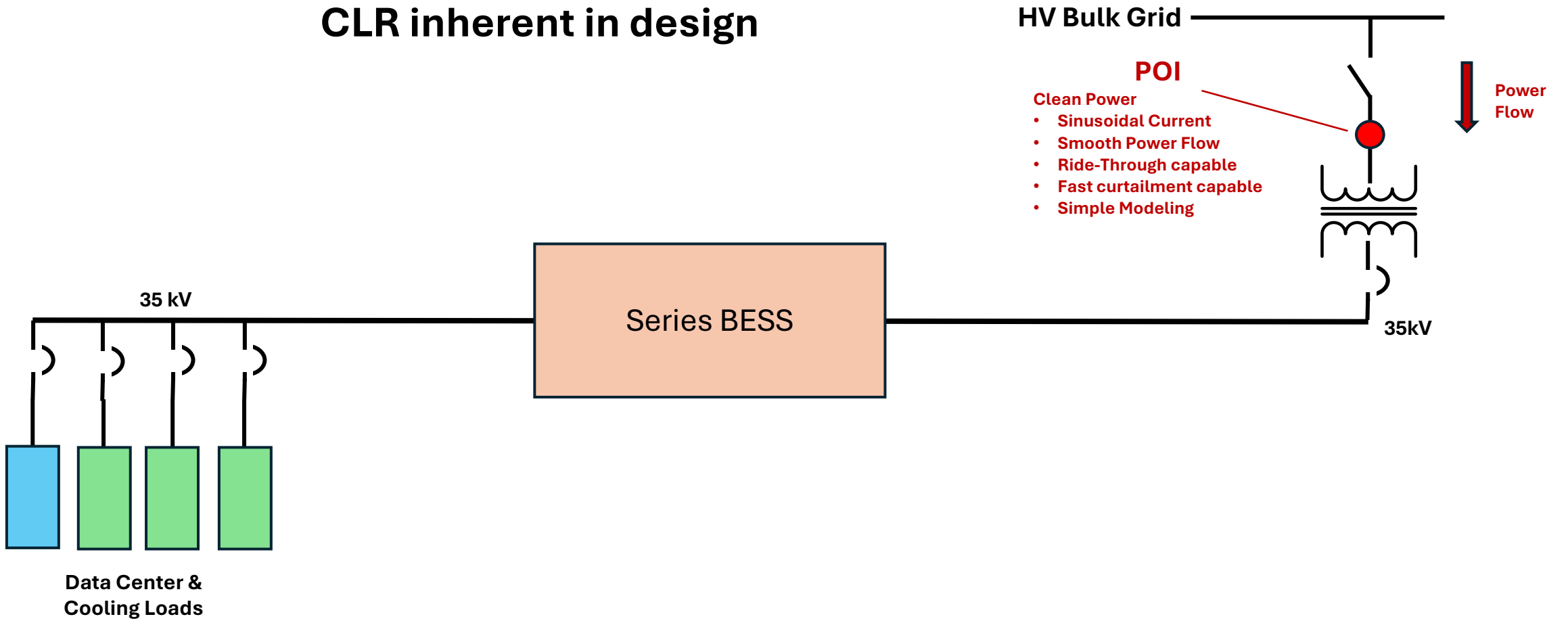
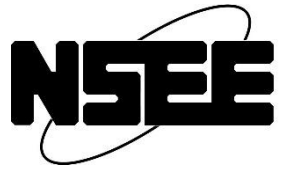

Block Diagram Example – Standard Load Interconnection with Series BESS

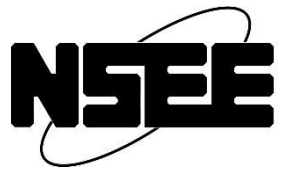

With optional cooling load bypass for efficiency & cost savings

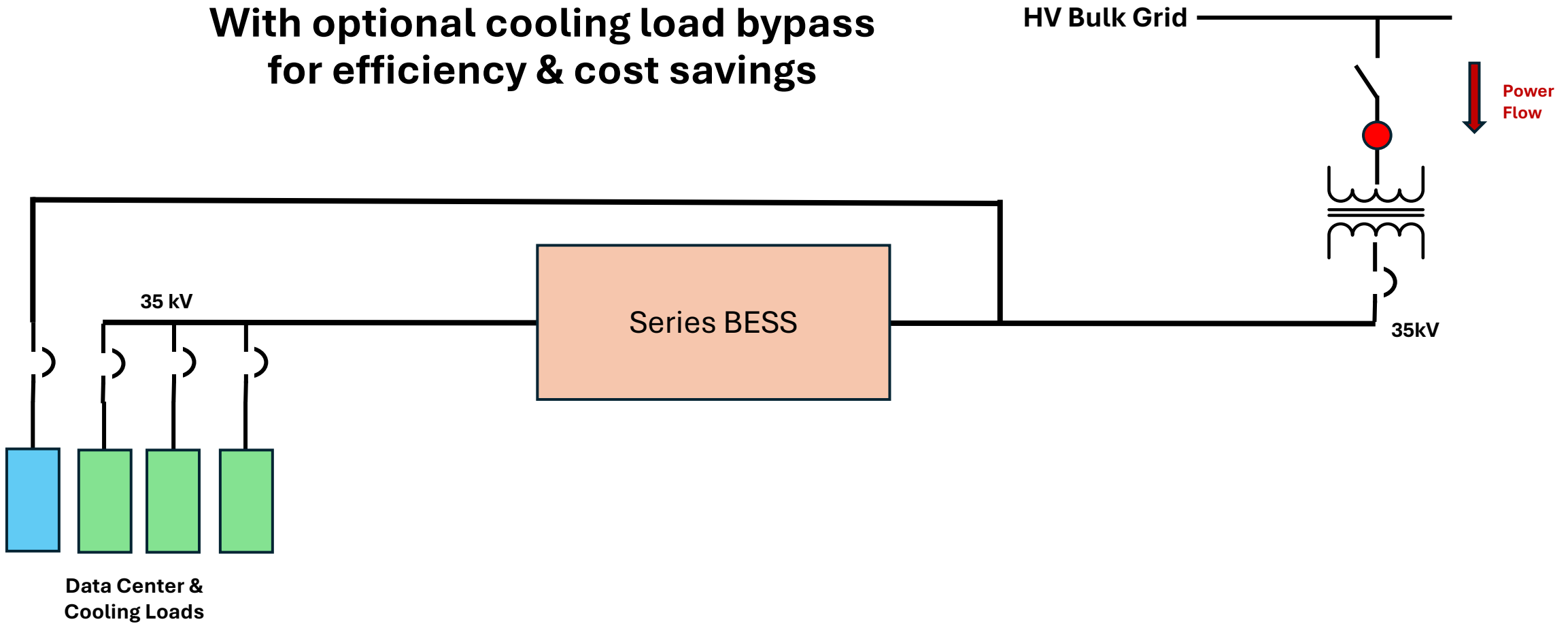

Block Diagram Example – Standard Load Interconnection with Series BESS & BYOG (&CLR)

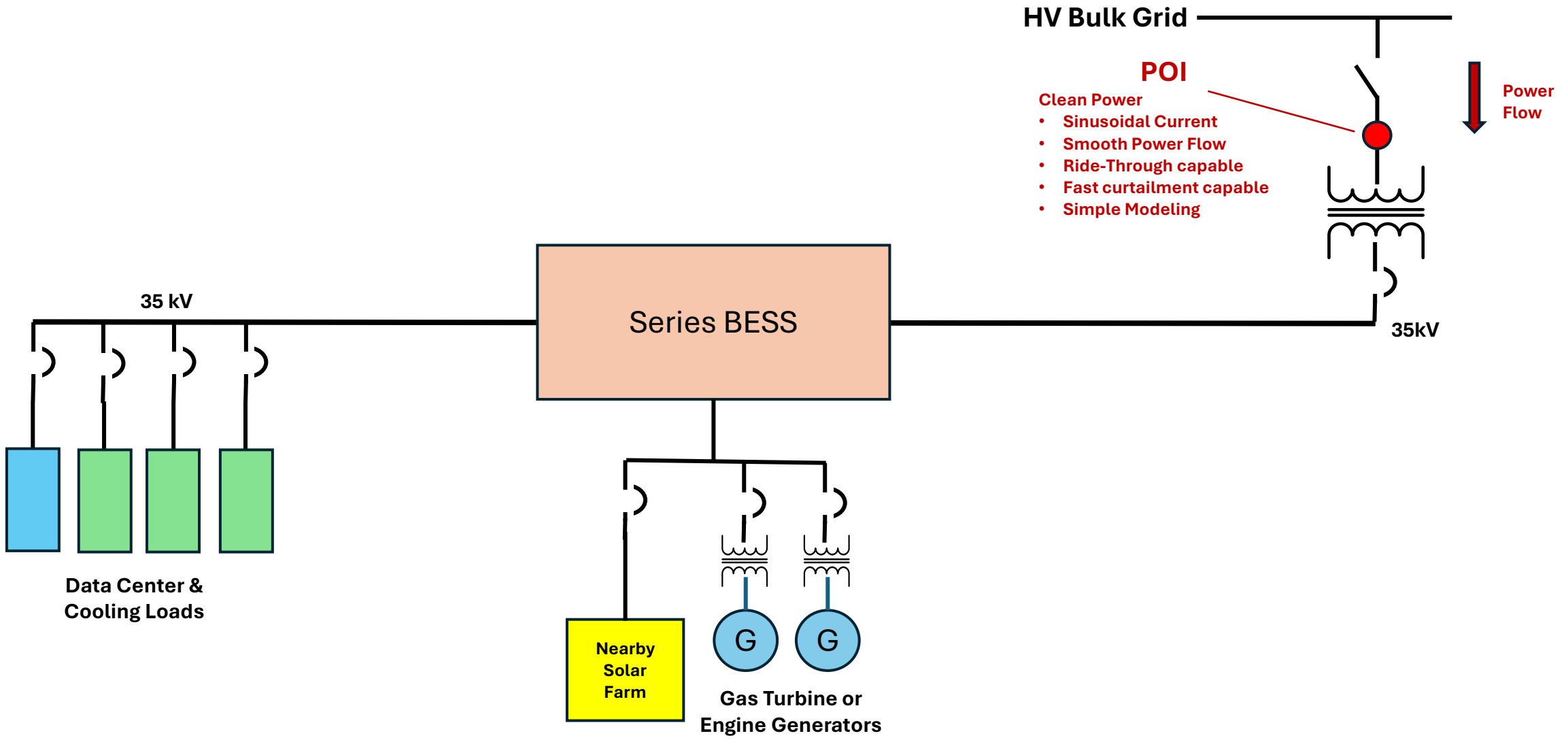

Block Diagram Example – Standard Load Interconnection with Series BESS & BYOG And Bi-Directional Power Flow

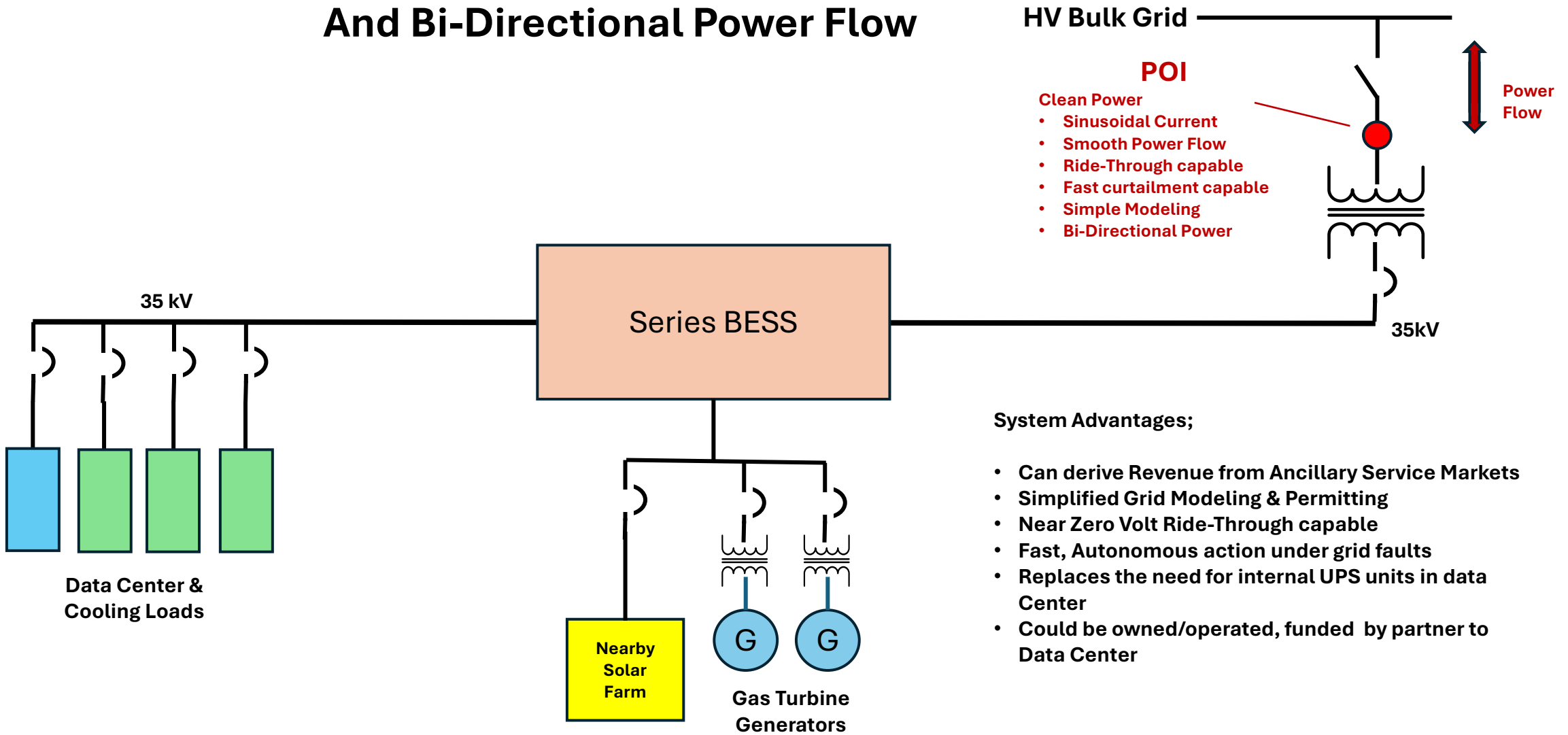
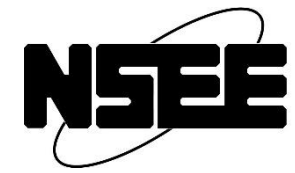

System Advantages;

- Can derive Revenue from Ancillary Service Markets
- Simplified Grid Modeling & Permitting
- Near Zero Volt Ride-Through capable
- Fast, Autonomous action under grid faults
- Replaces the need for internal UPS units in data Center
- Could be owned/operated, funded by partner to Data Center

Block Diagram Example – Back-to-Back AC/DC/AC PCS

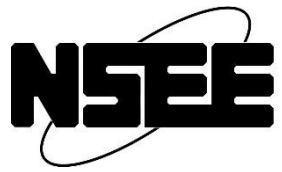

A solution for integrating data centers into the grid without the power quality concerns to the grid that AI data centers bring if synchronized.

This solution provides clean power to the gas turbines as well as bi-directional power exchange and grid stability services to the bulk grid through DC isolation. Due to the erratic nature of the AI load, Ultra-Capacitors are used instead of LFP Batteries

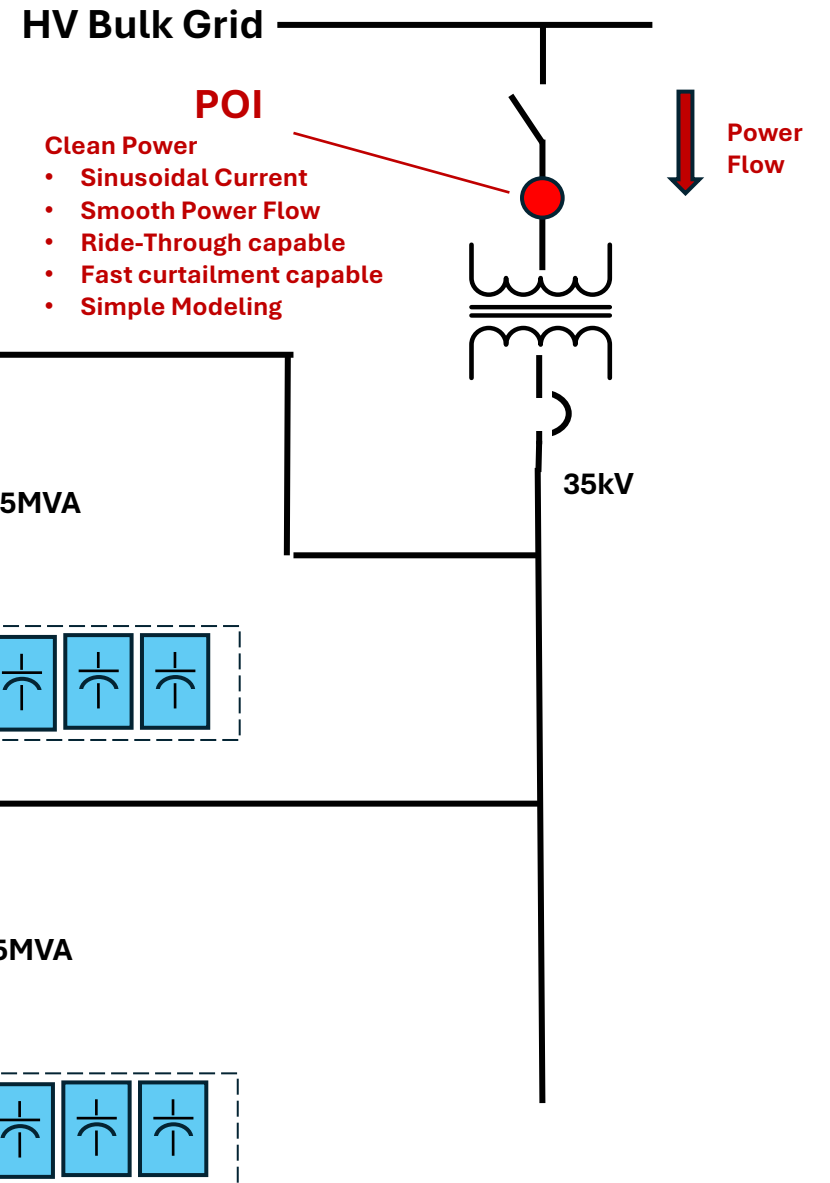
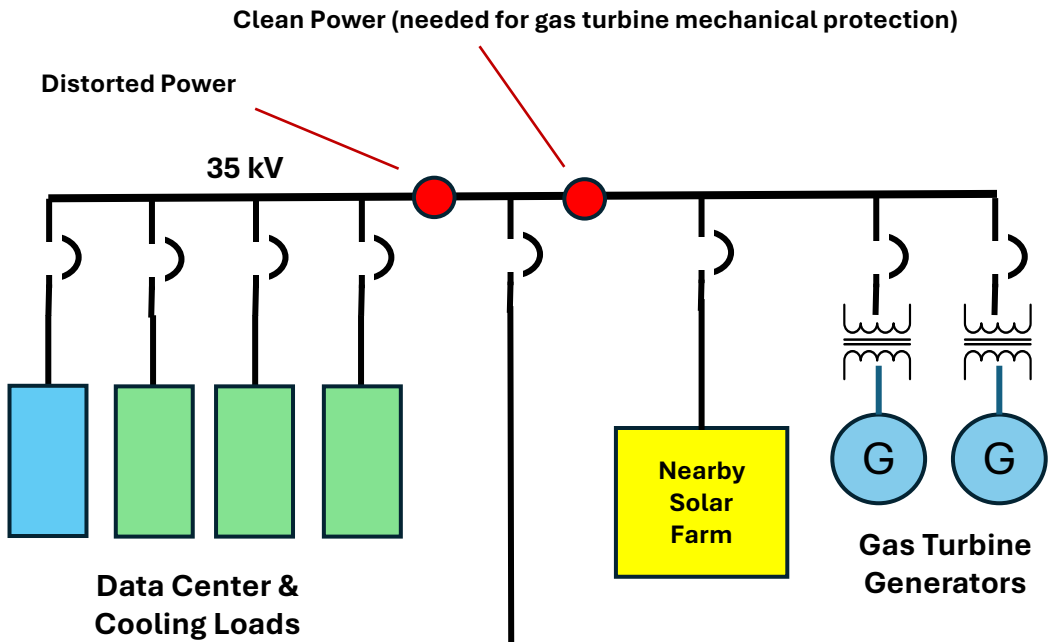

Block diagram of a 6MW AC/DC/AC Converter System with 20 ft. containers for packaging Ultra-Capacitors

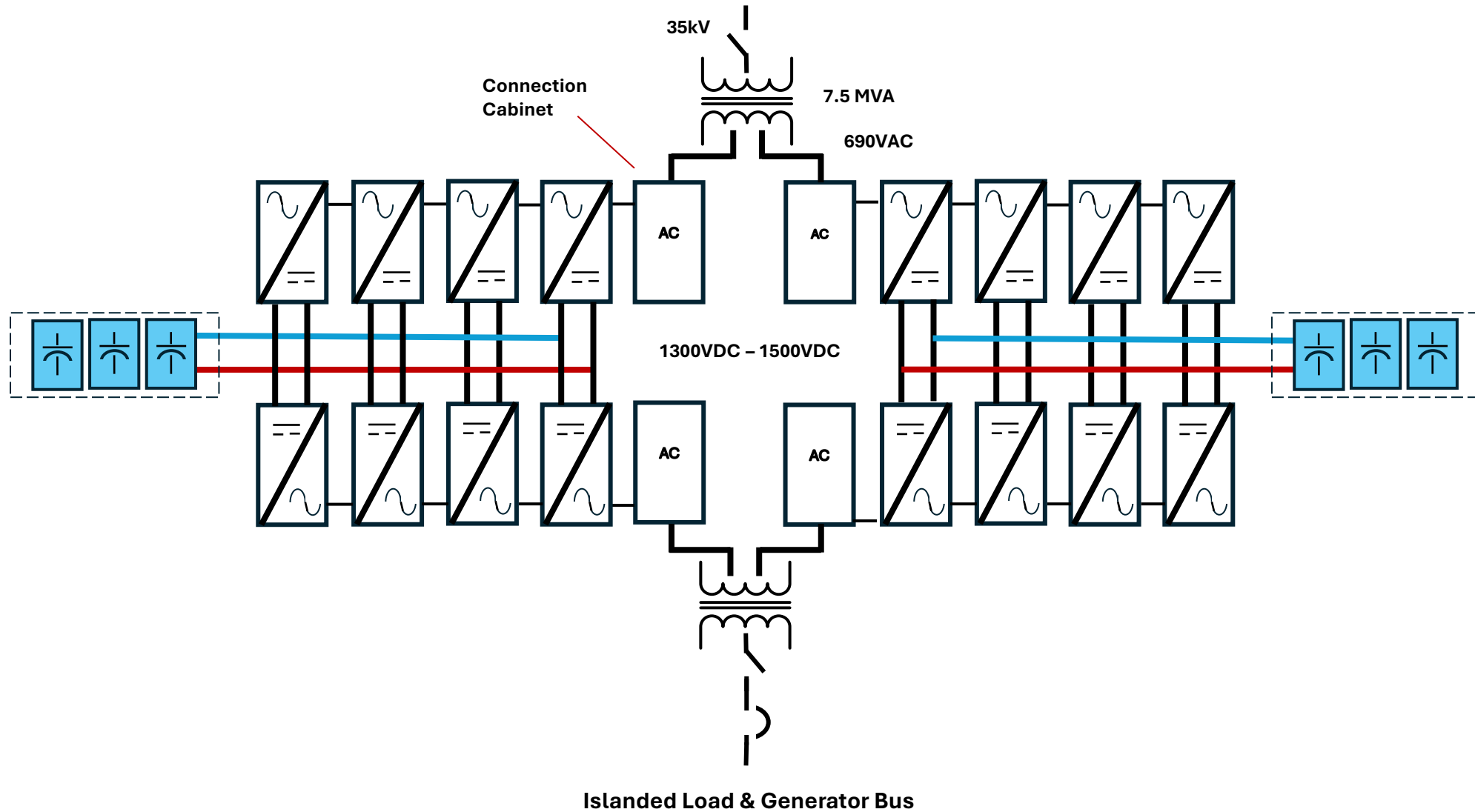
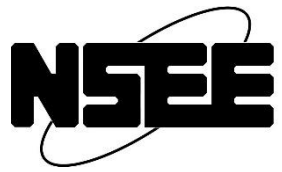

Field Installed PCS, part of an Industrial 6MW GFM BESS



Flexible arrangements of AC/DC and DC/DC Blocks can be connected as required on a common DC Bus

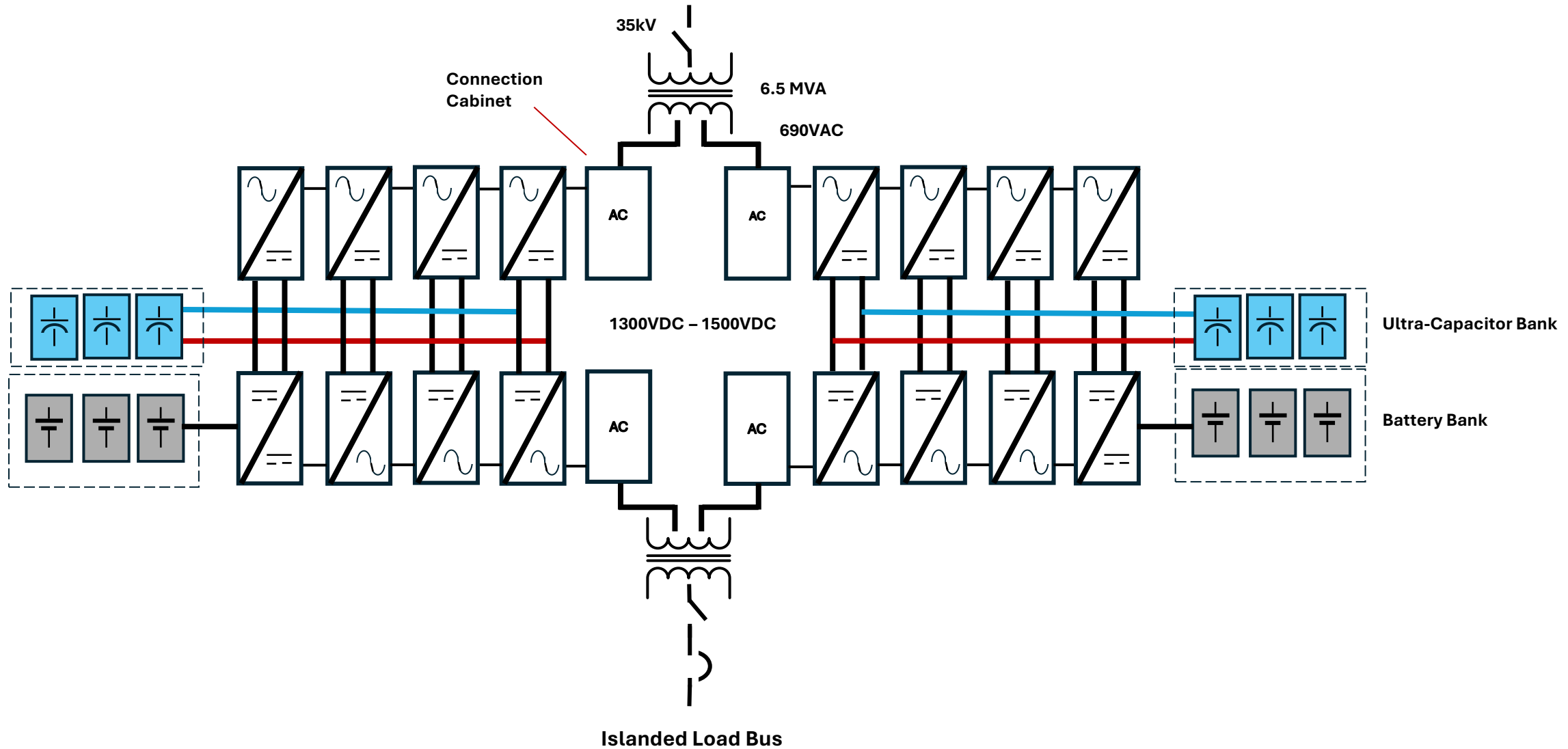
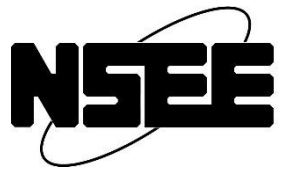

Many Units can be connected in parallel to achieve high power ratings,
 Grid Forming and Black Start on either side can also be supplied.
 Example; 40 parallel blocks = 200MW

35 kV
 3000A – 200MW

35 kV
 Utility
 Distribution

35kV Feeders on the left and right sides are NOT synchronized to each other.

Each side is connected similar to a standard BESS connection..

Batteries can also be mixed with Ultra-Capacitors for longer duration energy storage added to the high cyclic power conditioning needed for Data Centers

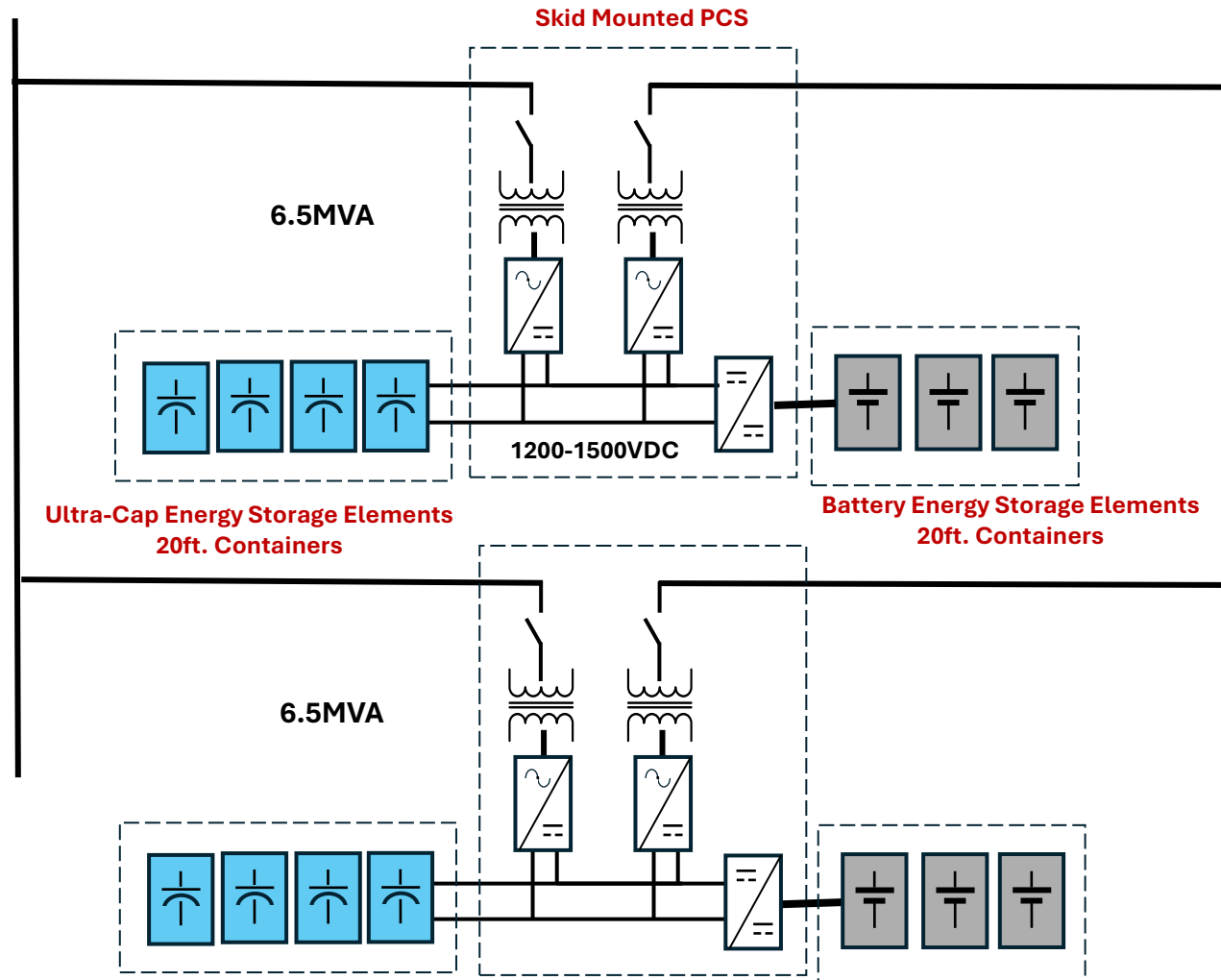

(12) **United States Patent**
McDonnell

(10) **Patent No.:** US 11,101,658 B2

(45) **Date of Patent:** Aug. 24, 2021

(54) **TECHNIQUES FOR ELECTRIC POWER DISTRIBUTION AND A SYSTEM IMPLEMENTING THE SAME**

(71) Applicant: **Non-Synchronous Energy Electronics, LLC**, St. Louis Park, MN (US)

(72) Inventor: **Alan McDonnell**, Hopkins, MN (US)

(73) Assignee: **NON-ASYNCHRONOUS ENERGY ELECTRONICS, LLC**, St. Louis Park, MN (US)

(*) Notice: Subject to any disclaimer, the term of this patent is extended or adjusted under 35 U.S.C. 154(b) by 0 days.

(21) Appl. No.: **16/411,082**

(22) Filed: **May 13, 2019**

(65) **Prior Publication Data**

US 2020/0235580 A1 Jul. 23, 2020

Related U.S. Application Data

(60) Provisional application No. 62/794,038, filed on Jan. 18, 2019.

(51) **Int. Cl.**
H02J 3/34 (2006.01)
H02J 3/38 (2006.01)
H02J 3/32 (2006.01)
G05B 19/042 (2006.01)

(52) **U.S. Cl.**
 CPC **H02J 3/34** (2013.01); **G05B 19/042** (2013.01); **H02J 3/32** (2013.01); **H02J 3/383** (2013.01); **H02J 3/386** (2013.01); **G05B 2219/2639** (2013.01)

(58) **Field of Classification Search**
 CPC H02J 3/34; H02J 3/32; H02J 3/383; G05B 19/042

See application file for complete search history.

(56) **References Cited**

U.S. PATENT DOCUMENTS

8,073,573 B2* 12/2011 Chassin H02J 13/00002
 700/286
 8,159,178 B2* 4/2012 Serban G05F 1/67
 320/101
 8,183,714 B2 5/2012 McDonnell
 9,793,755 B2* 10/2017 Garrity H02J 7/007
 2012/0200155 A1 8/2012 McDonnell
 2013/0054987 A1* 2/2013 Pfeiffer G06F 1/305
 713/300
 2014/0001845 A1* 1/2014 Bonicatto H02J 3/14
 307/11
 2015/0357936 A1* 12/2015 Jeon H02M 7/537
 363/97
 2015/0372490 A1* 12/2015 Bakas H02M 7/42
 307/52

(Continued)

Primary Examiner — Vincent H Tran

(74) *Attorney, Agent, or Firm* — Grossman, Tucker, Perreault & Pfeiffer, PLLC

(57) **ABSTRACT**

Techniques are disclosed for providing a variable output micro-grid frequency in order to cause loads and producers coupled to a micro-grid to change operating modes/behaviors accordingly. For example, the utility frequency delivered via the micro-grid may be used as a control signal for the purposes of demand response, e.g., increasing or decreasing load, energy storage control, e.g., to cause storage of energy or the discharging of energy, and generator output curtailment as is mandated by generator interconnection standards such as UL1741 for output power curtailment under high frequency.

18 Claims, 2 Drawing Sheets

Connecting Synchronous Generators to the Non-Synchronous Load Bus

NSEE holds a Patent for the design of a system where the synchronous generators can be connected to a MV feeder without having to submit to standard generator interconnection permitting and limitations from the bulk grid.

The main advantages of this system design include overcoming the size limitations of the bulk grid and not incurring PCS losses between the generator and load.

Other advantages include less mechanical stress and higher efficiencies on the turbine or engine, and not being required to trip during a grid loss (for UPS power).

Depending upon the system and chosen generators, the variable frequency capabilities of the GFM output inverters may be able to make use of the rotating inertia of the generators to reduce the amount of energy storage needed, and protect against torsional stress by controlling generator torque.

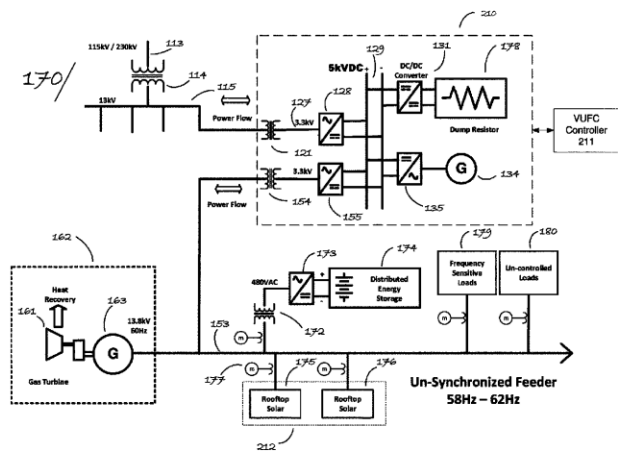

From AC to VDC

Moving to an 800 VDC Architecture

Data center architectures will gradually evolve from today's AC distribution to 800 VDC. The NVIDIA 800 VDC architecture supports all existing data centers while providing a smooth path to an all 800 VDC future.

2025

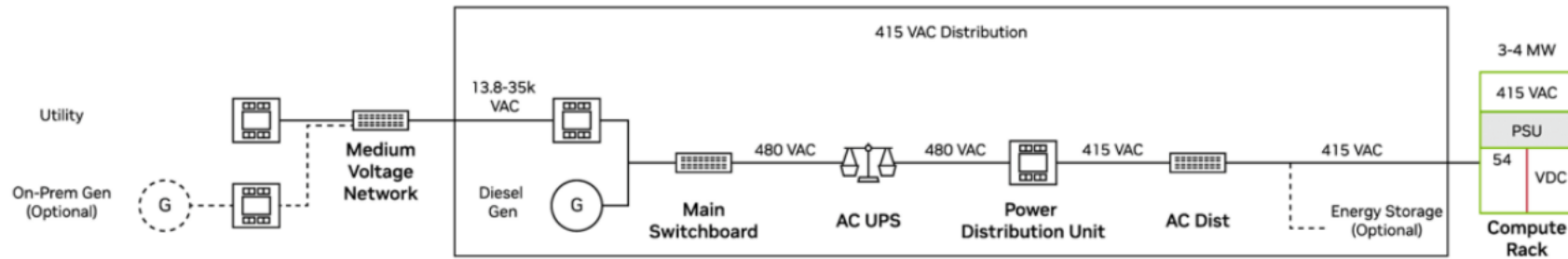

2027

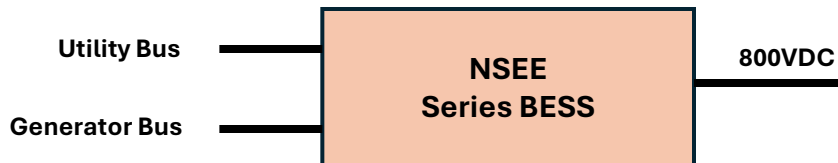
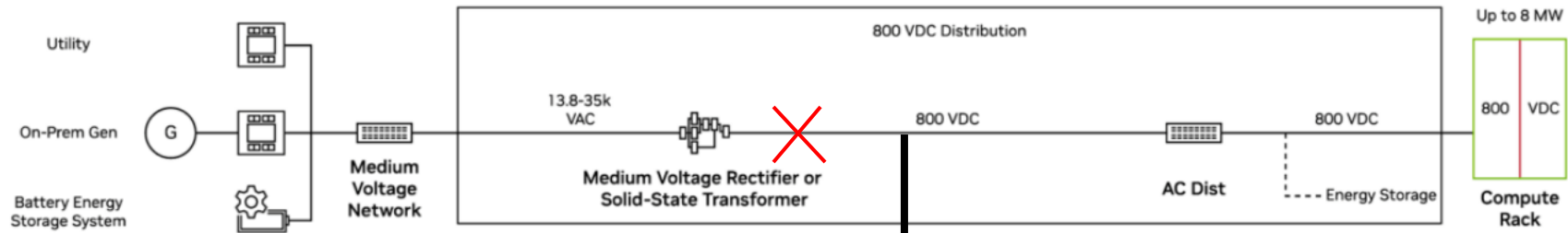

A flexible arrangement for feeding an 800VDC Data Center

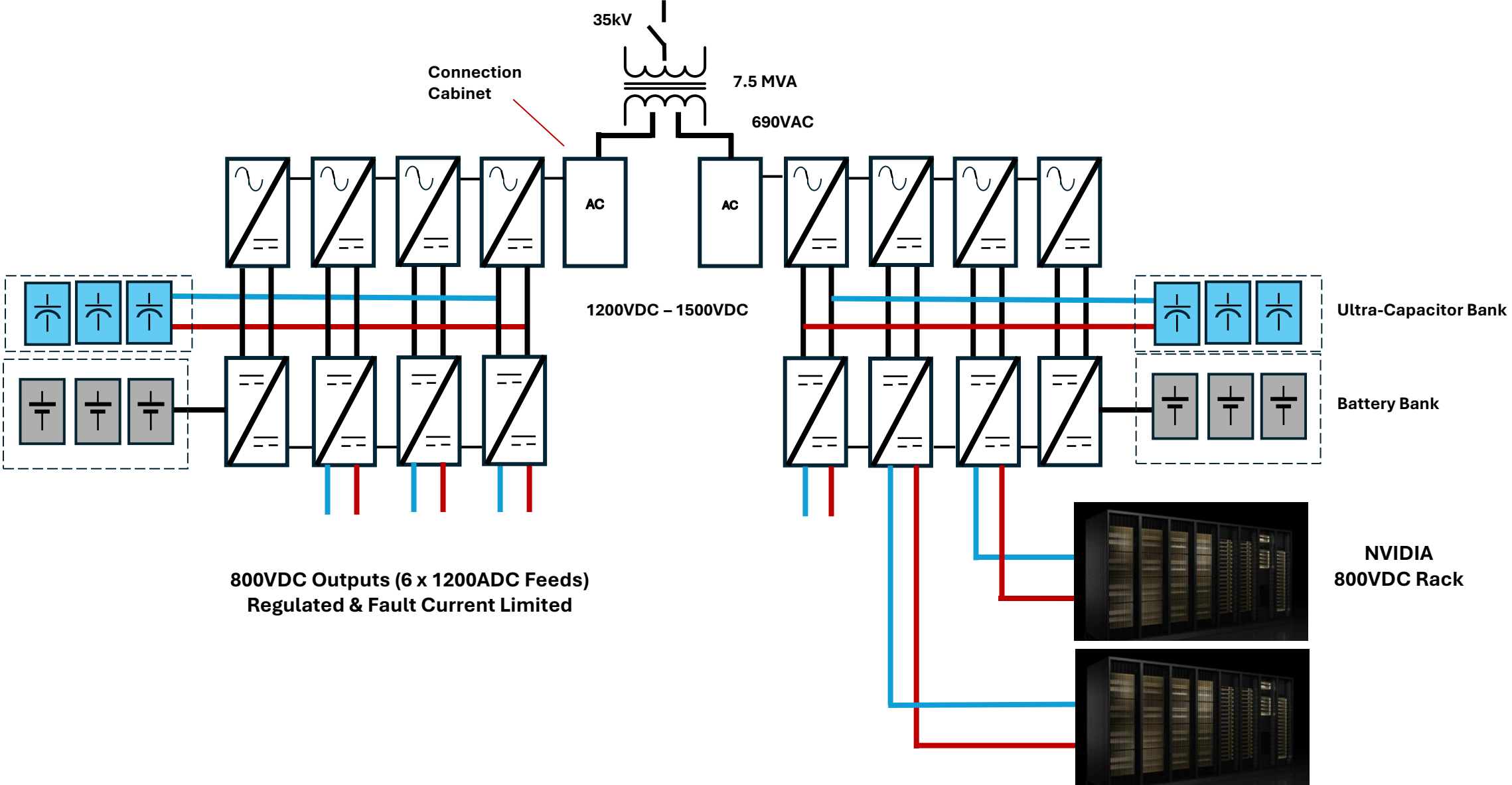

Flexible arrangements of AC/DC and DC/DC Blocks can be connected as required on common DC Buses, as per the previous slide, for Islanded Generation, Grid and 800VDC output w/Ultra-Caps & Batteries

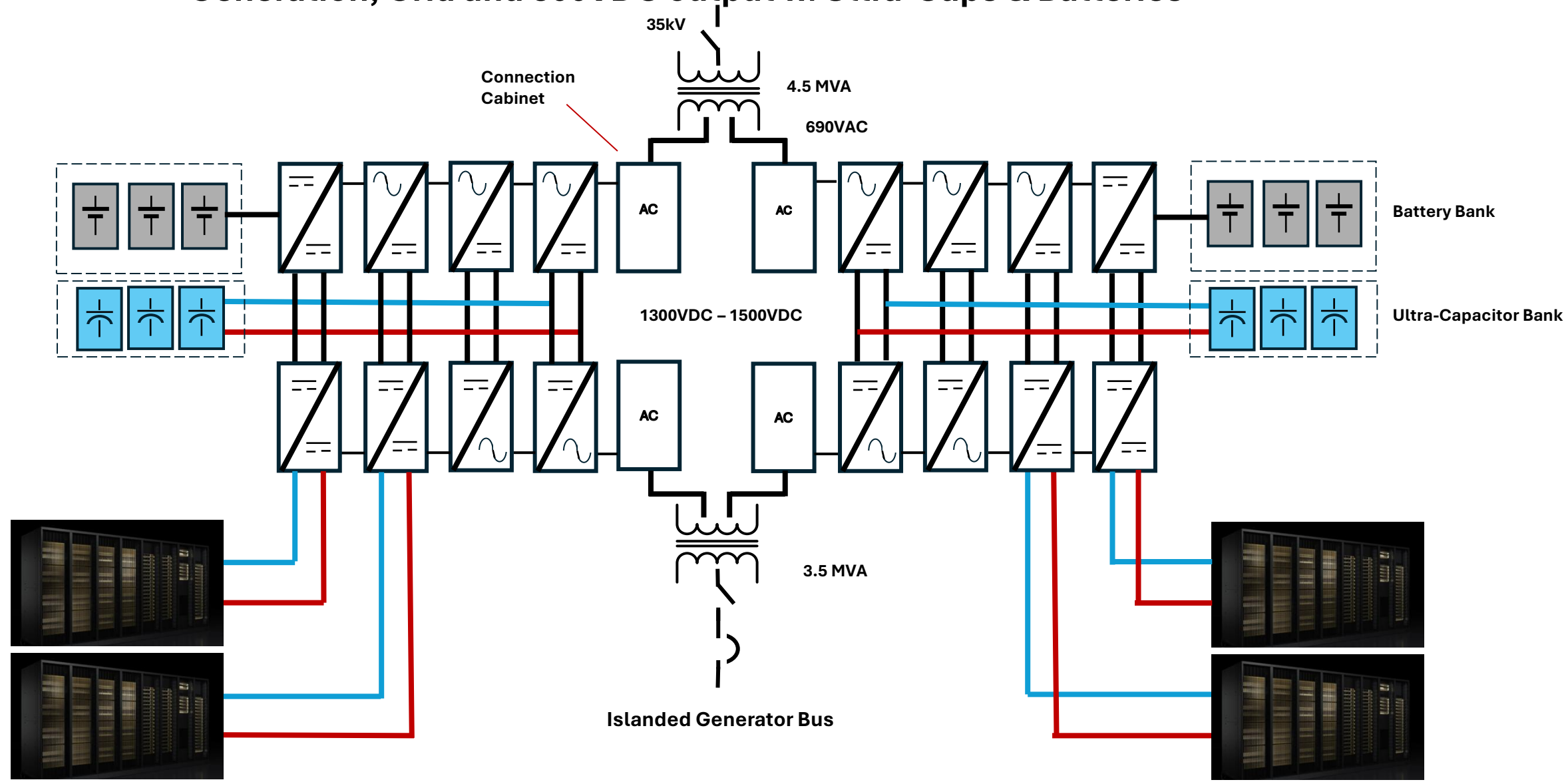

Example, planned large off-grid Power and Data Center



NSEE can integrate these into the grid and use as a grid asset



- **Some projects are being built off-grid to avoid interconnection delays.**
- **These projects could benefit from connecting some of their capacity to nearby transmission lines, permitting similar to a standard BESS project**
- **This would allow the project to bid into ERCOT markets, once approved**
- **By making use of nearby transmission lines, the connections could be sized to not require upgrades of these lines, and improve the stability and both load and hosting capacity of the areas around them.**

Islanded Power and Data Center HV Grid

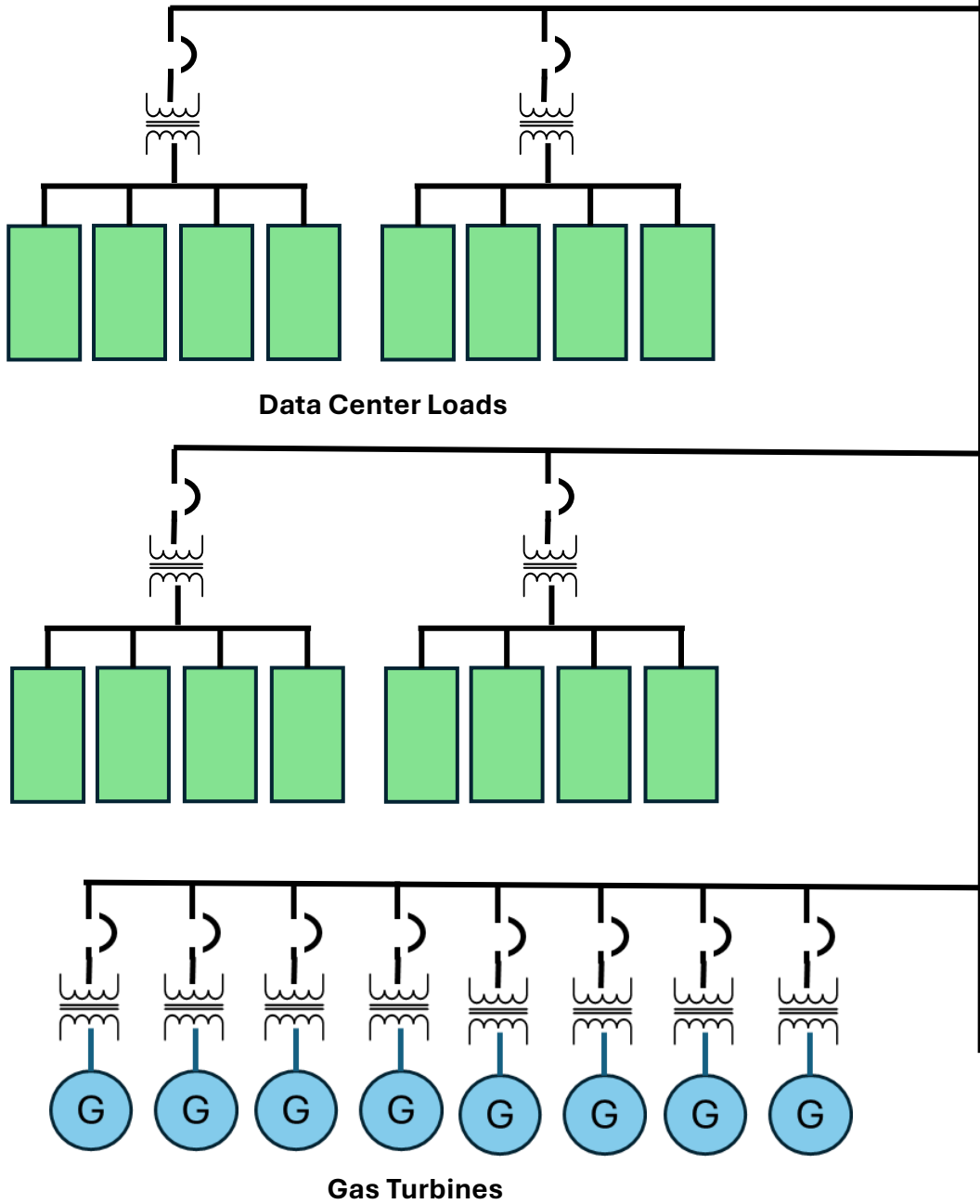

Data Center Loads

Gas Turbines

Series BESS

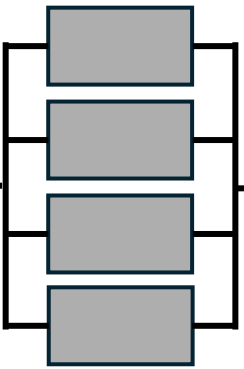

Power Flow

Series BESS

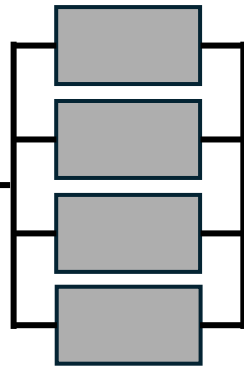

Power Flow

345kV

Nearby HV Transmission Line #1

138kV

Nearby HV Transmission Line #2

- Clean Power Interconnection
- Sinusoidal Current
 - Smooth Power Flow
 - Advance Grid Support
 - FFR (mSec) Curtailment
 - No PERC1 load modelling needed



US 20250088006A1



(19) **United States**
 (12) **Patent Application Publication** (10) **Pub. No.: US 2025/0088006 A1**
McDonnell (43) **Pub. Date: Mar. 13, 2025**

(54) **TECHNOLOGIES FOR ENERGY STORAGE DRIVEN SYNCHRONOUS CONDENSERS** (52) **U.S. CL.**
 CPC *H02J 3/38* (2013.01); *H02P 6/08* (2013.01); *H02J 2203/10* (2020.01)

(71) Applicant: **Non-Synchronous Energy Electronics, LLC**, St. Louis Park, MN (US)

(72) Inventor: **Alan McDonnell**, Hopkins, MN (US)

(21) Appl. No.: **18/434,157**

(22) Filed: **Feb. 6, 2024**

Related U.S. Application Data

(60) Provisional application No. 63/581,437, filed on Sep. 8, 2023.

Publication Classification

(51) **Int. Cl.**
H02J 3/38 (2006.01)
H02P 6/08 (2006.01)

(57) **ABSTRACT**
 Technologies for power grid regulation include a synchronous machine coupled to a high voltage power grid, an induction motor mechanically coupled to the synchronous machine, a power converter coupled to the induction motor, and an energy storage device coupled to the power converter. A controller may be configured to regulate torque of the induction motor by controlling output of the power converter. The controller may selectively cause the power converter to transfer energy from the energy storage device to the induction motor and to transfer energy from the induction motor to the energy storage device. The controller may regulate speed of the induction motor using a shaft speed sensor coupled to the induction motor. The controller may be configured to cause the power converter to start rotation of the induction motor when the high voltage power grid is not energized. Other embodiments are described and claimed.

Ustream Grid Stability and Grid Strength

NSEE is focused on optimizing the entire grid system, including power generation optimization, frequency stability, short circuit ratio, system oscillation and associated issues relevant to a strong and reliable grid.

One of the solutions we are working on involves using energy storage coupled with synchronous condensers/generators to provide these services.

A Patent will soon be issued for the system shown.

This will also allow for much more renewable energy, especially nearby connected solar power, to replace gas turbines in the functions of forming and stabilizing the grid.

Although there are not yet any ancillary service markets for such services, integrating such systems into the energy storage of a data center will allow for higher capacity from the existing or planned transmission feeders.

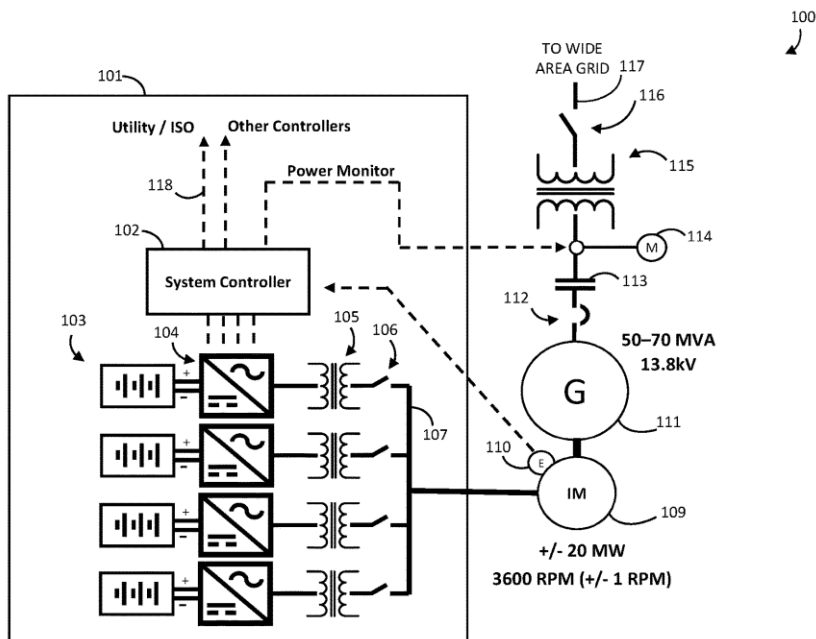

A more detailed description of an Energy Storage Driven Synchronous Condenser (ESDSYC), sized similar to an LM6000 gas turbine generator

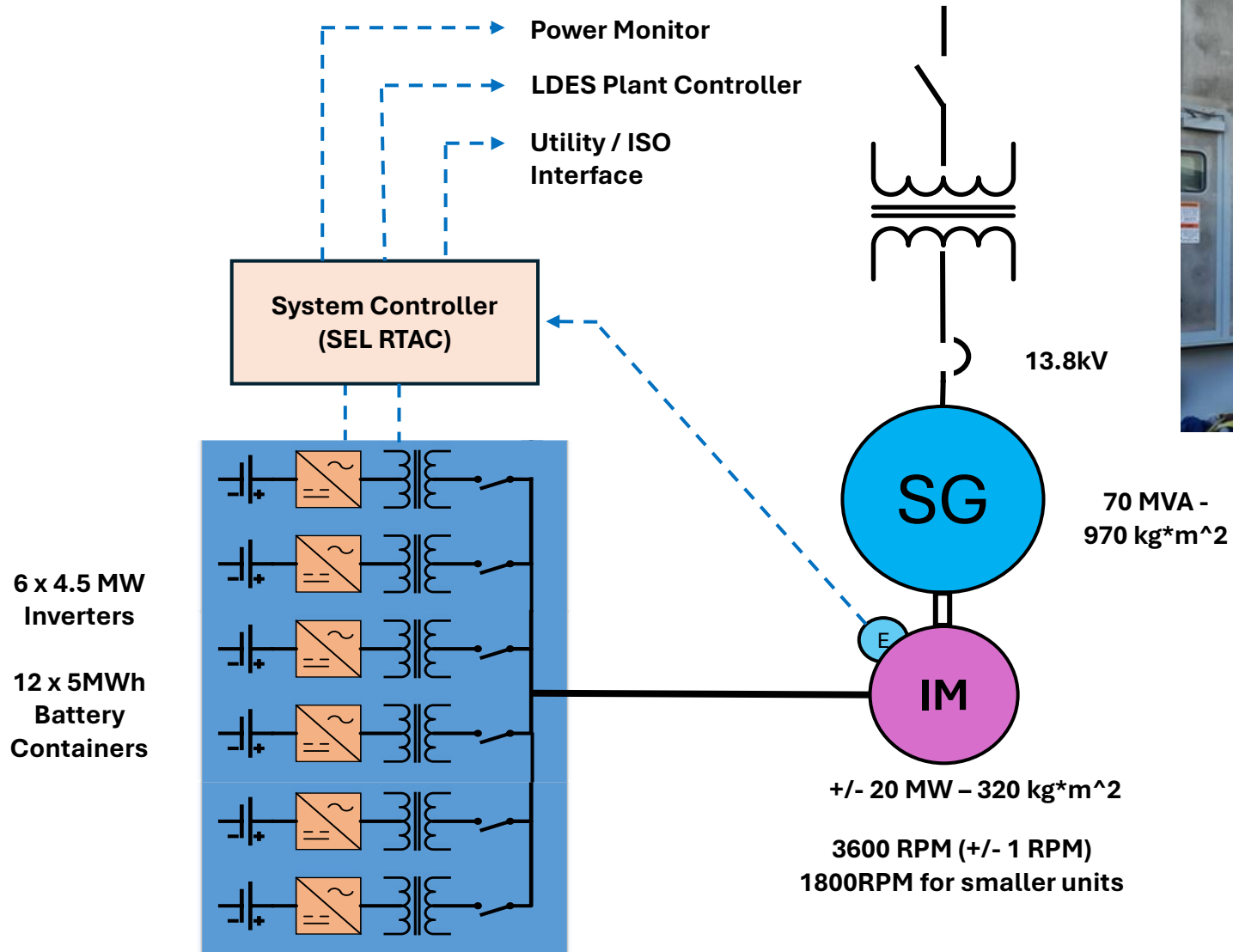
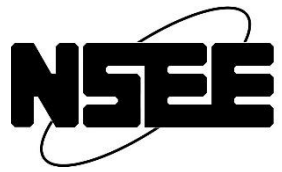

Replace the Gas Turbine in the Generator Set with an Induction Motor

A performance example (NREL) of a traditional parallel connected Sync Condenser and BESS with grid forming inverter

In order to produce a steady state FFR output, the BESS needs to be sized at 275% of the Continuous output in order to stabilize the sync condenser

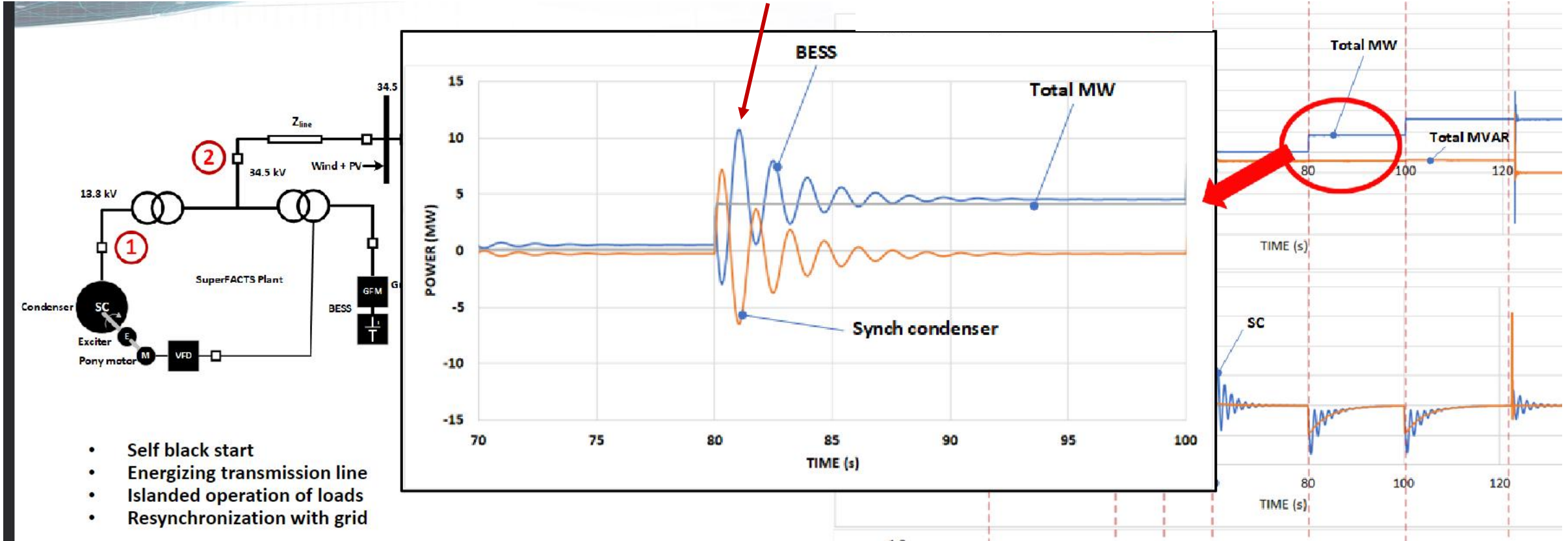

- Self black start
- Energizing transmission line
- Islanded operation of loads
- Resynchronization with grid

The time to settle the oscillations for a step change in load is about 8 sec.

The freewheeling sync condensers being added to the ERCOT grid could increase the sub-synchronous oscillation problems, especially with more LELs added.

Example ESDSYC Power Output Response

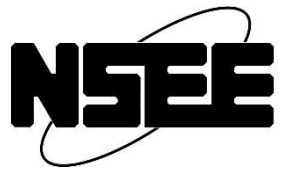

25 deg. Phase Angle Jump; also an example of system oscillation damping

Phase angle jump 25 deg
Case B: (Natural) inertia response
+ P(f) droop through inverter control

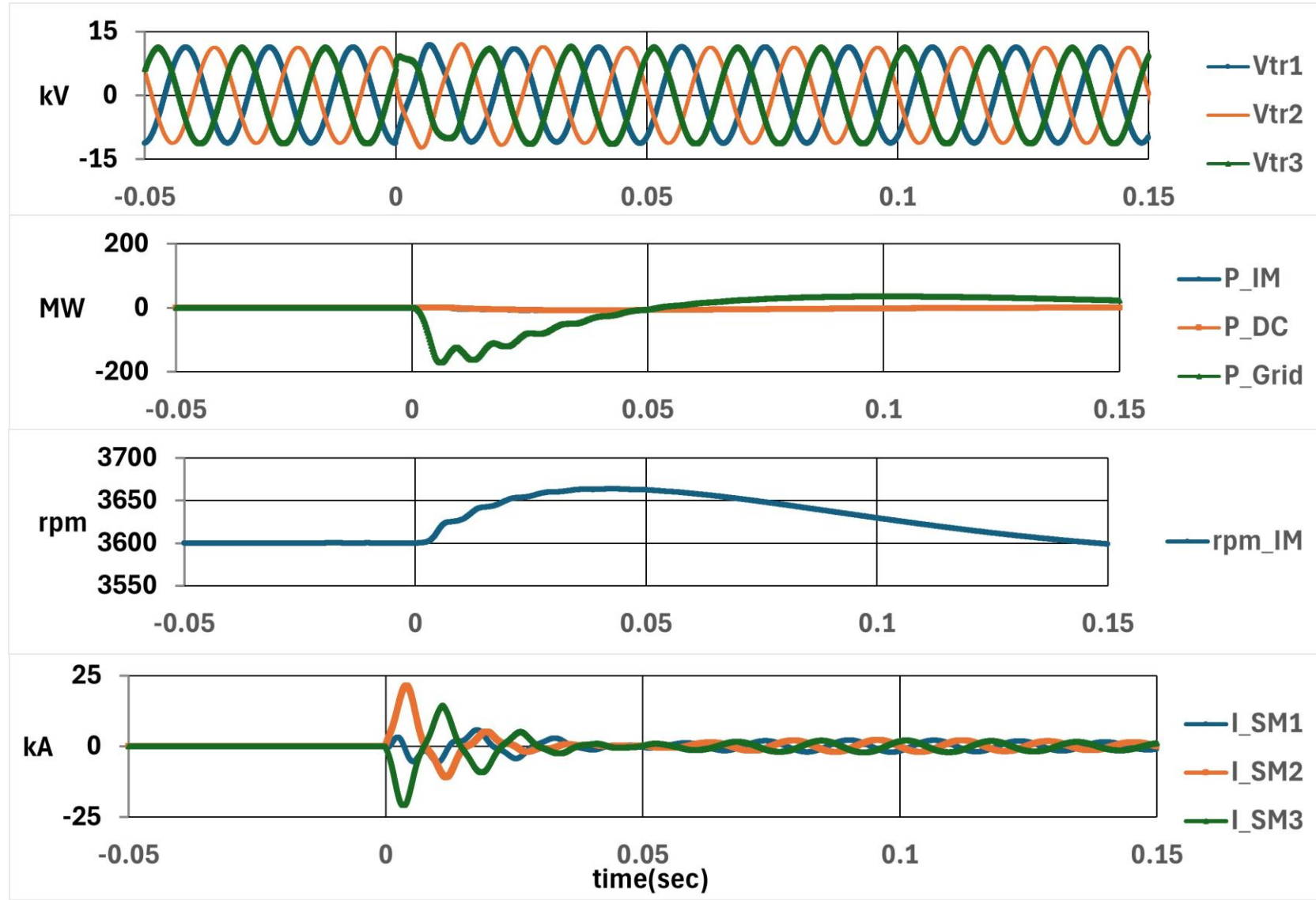

A phase angle jump is simulated by switch-over between two grid supplies with 25 degrees phase displacement. The current and torque transients are largely settled in about 50 msec, without loss of synchronization

All Hardware-in-the-loop (HIL) simulations conducted directly by Indrivetec

FFR Performance evaluation comparison between ESDSYC and a standard inverter BESS

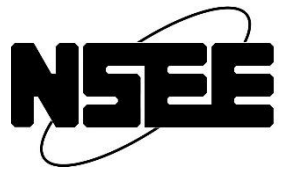

Comparison between ESDSYC, with 30MW IM Power shown, and a standard 50MW BESS, same -5Hz/Sec. RoCoF

Generally about 150mSec vs 250mSec to full output

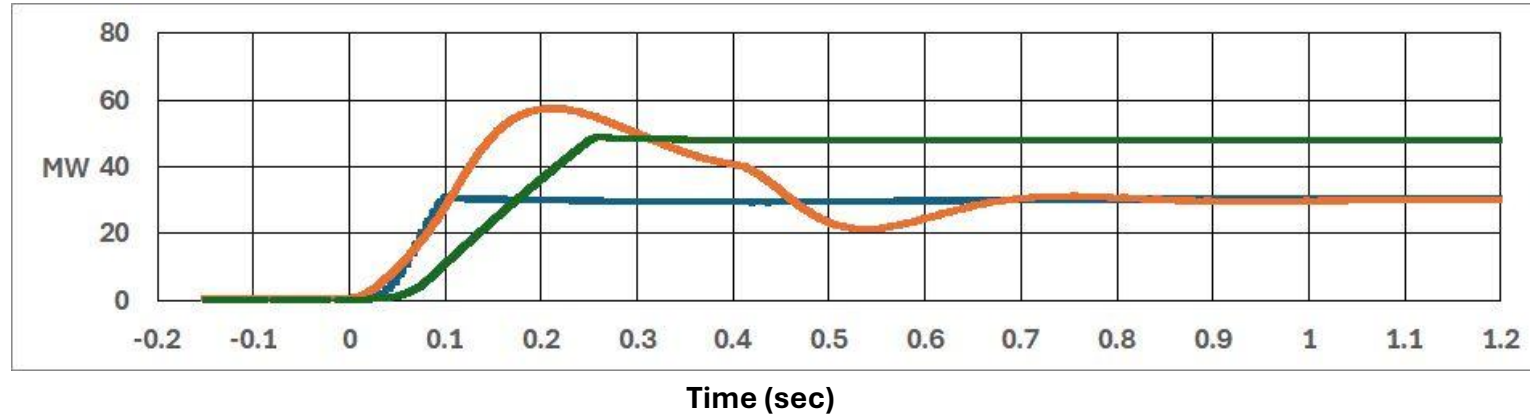

Comparison of a standard 100MW BESS under FFR vs. an 80MW BESS combined with a 20MW Induction Motor ESDSYC

Generally about 80mSec. Faster to full power and an extra 30MW short term inertia boost

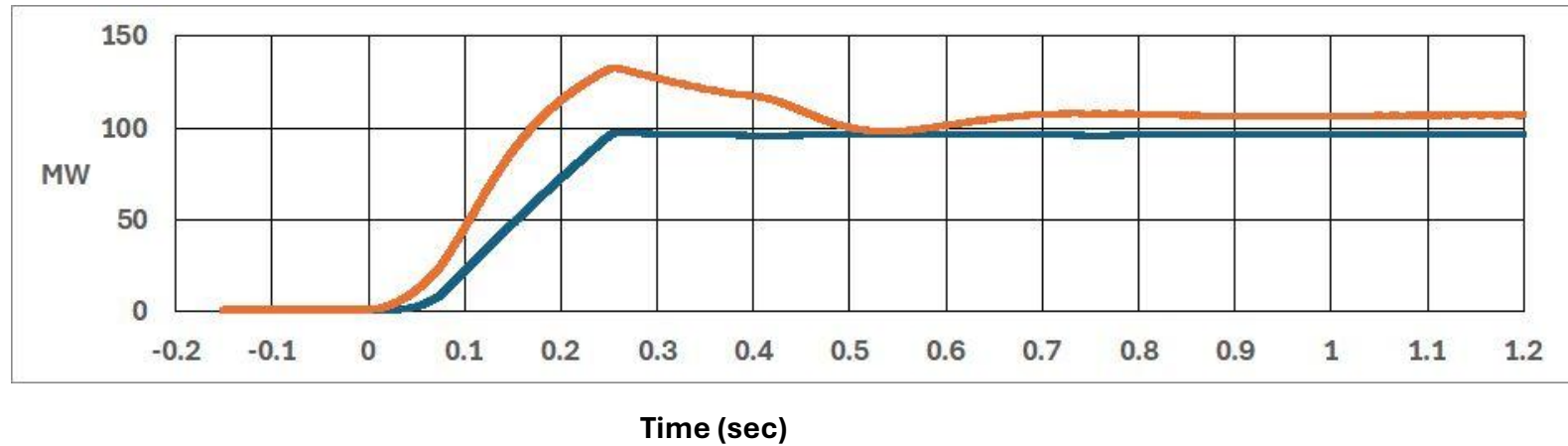

FaFR (*Faster Frequency Response*)

Islanded Power and Data Center HV Grid

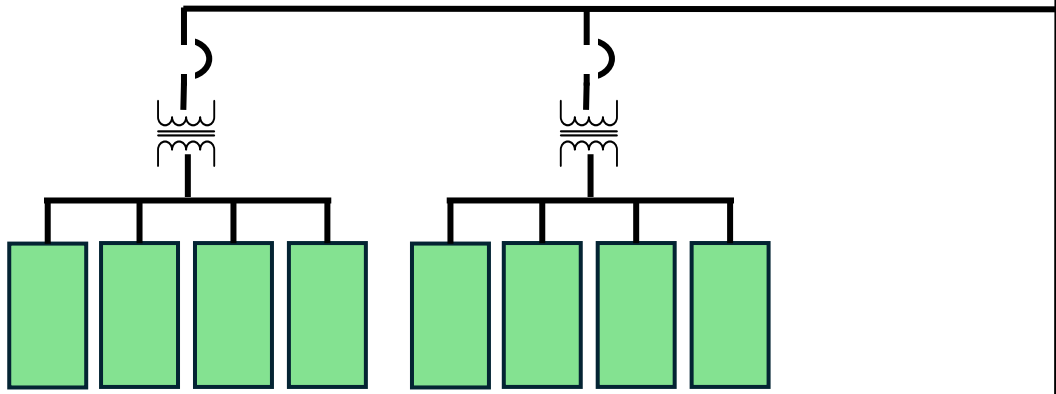

Data Center Loads

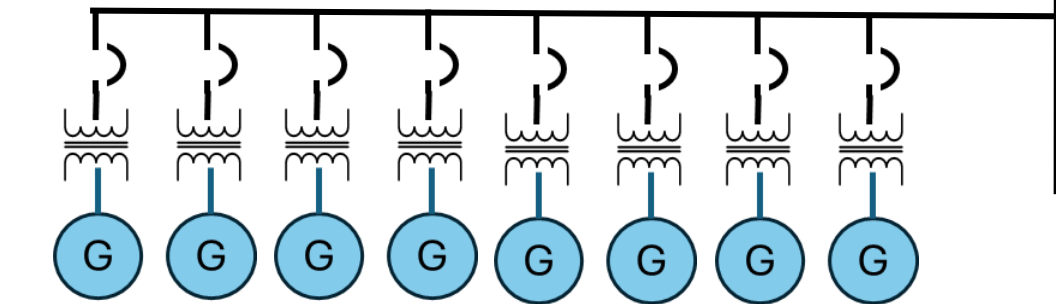
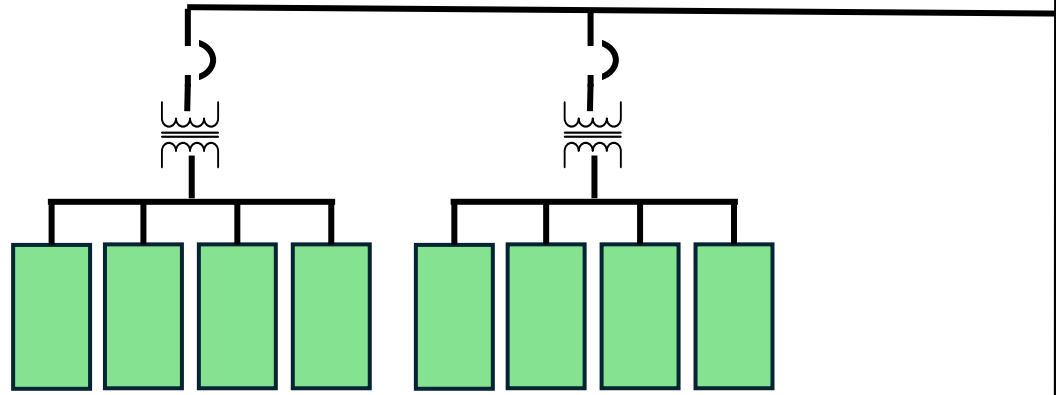

Gas Turbines

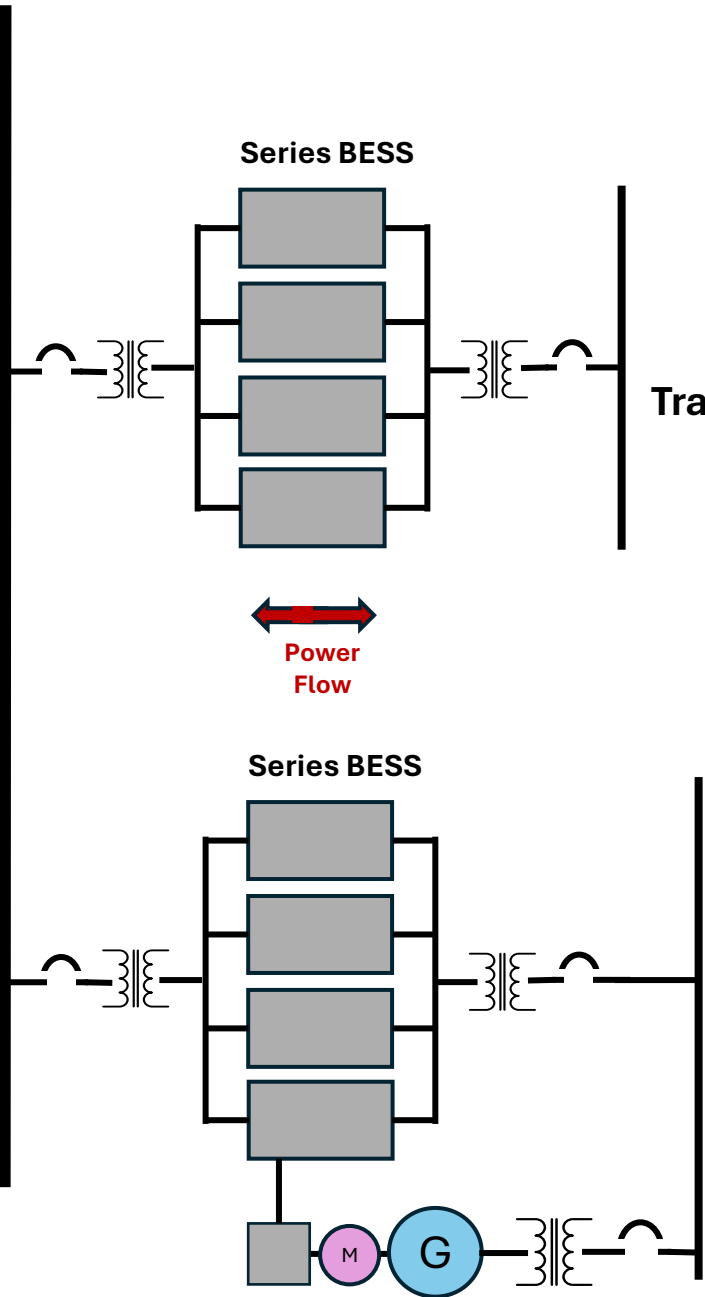

Series BESS

Series BESS

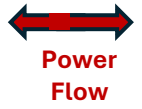

Nearby HV Transmission Line #1

Nearby HV Transmission Line #2
With higher SCR
and dampened SSO

- Clean Power Interconnection**
- Sinusoidal Current
 - Smooth Power Flow
 - Advance Grid Support
 - FFR (mSec) Curtailment
 - No PERC1 load modelling needed



Non-Synchronous Energy Electronics, LLC

These, and other customized applications can be configured as needed. We look forward to discussing in further detail. For more information, please contact;

Alan McDonnell, President

Non-Synchronous Energy Electronics, LLC

5115 Excelsior Blvd., #330

St. Louis Park, MN 55416

(603) 546-5785

alan.mcdonnell@nonsynchronous.com

Kevin McDonnell P.Eng (British Columbie)

NSEE Canada

kevin.mcdonnell@nonsynchronous.com

www.nonsynchronous.com