

# AEPSC Laredo Area Upgrades

## Overview for 26RPG004

April 13<sup>th</sup> 2026

# Background

---

- This project is intended to address thermal and voltage violations identified in AEP's annual TPL-001 assessment.
- Thermal and voltage issues driven by rapid load growth within the Laredo district and not necessarily driven by 'large loads'.
- AEP evaluated three upgrade options to address identified reliability issues.

# Option 1

## Transmission Line Additions/Modifications

- Rebuild the 3.25-mile Wormser Road – Santo Nino 138 kV line to minimum of 2000 A capability. Will target 478 MVA normal and emergency ratings.
- Rebuild 19.8-mile North Laredo Switch – Unitec – Gateway East Tap 138 kV line to minimum of 3000 A capability. Will target 717 MVA normal and emergency ratings.
- Rebuild 6.9-mile University – Gateway West Tap 138 kV line to minimum of 3000 A capability. Will target 717 MVA normal and emergency ratings.
- Rebuild 1.37-mile Fincas – Gateway West Tap 138 kV line to minimum of 3000 A capability. Will target 717 MVA normal and emergency ratings.
- Construct two additional terminals at Wormser Road and install (2) +/- 150 MVAR STATCOM at Wormser Road station.
- AEP to perform necessary station upgrades as to not limit any of the lines proposed for rebuild.

## Station Addition/Expansion

- Construct two additional terminals at Wormser Road and install (2) +/- 150 MVAR STATCOM at Wormser Road station.
- AEP to perform necessary station upgrades as to not limit any of the lines proposed for rebuild.

# Option 1

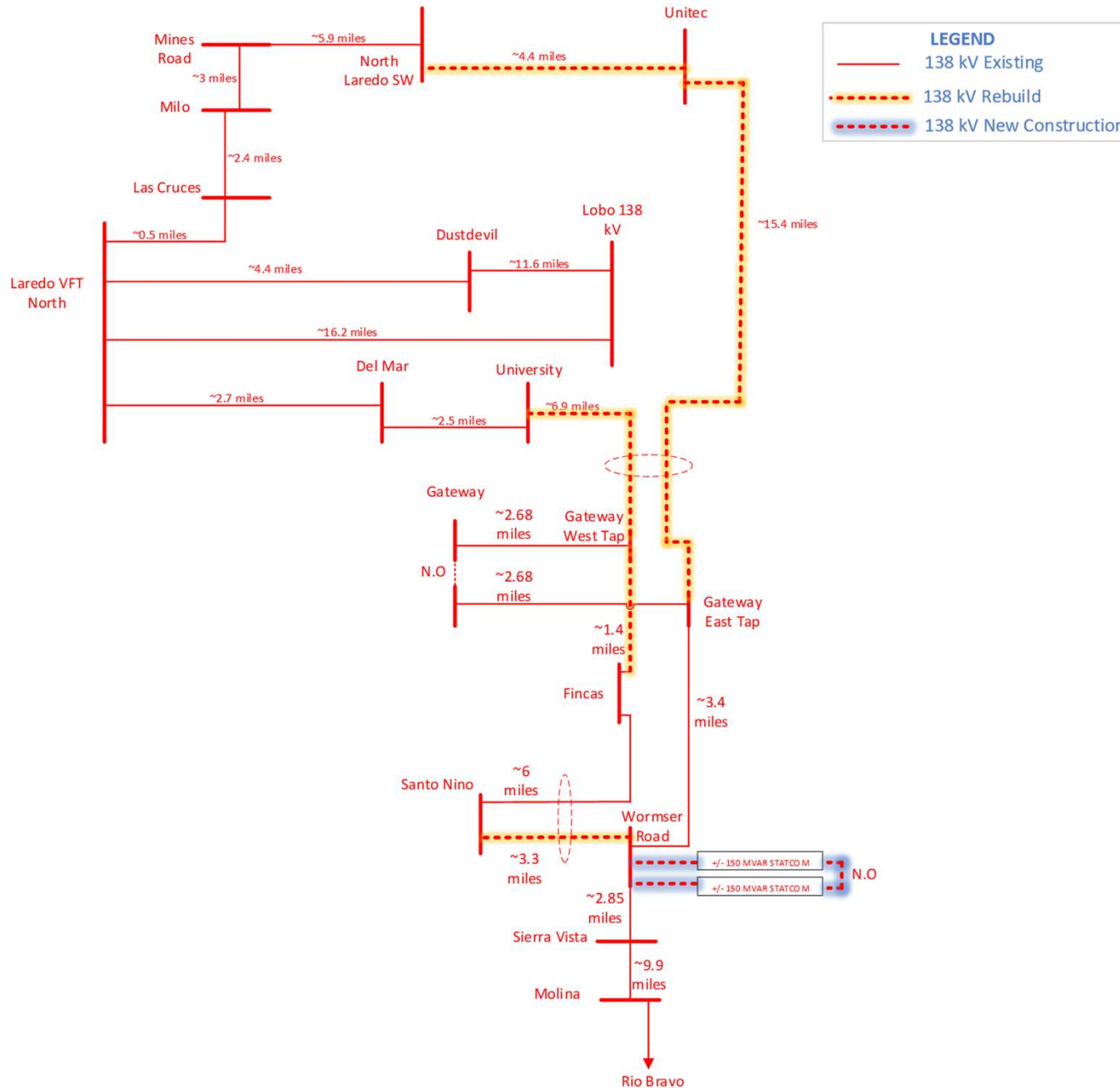

# Option 2

## Transmission Line Additions/Modifications

- Construct greenfield ~9.5-mile double circuit Molina – Wormser 138 kV line. Line will be designed/constructed to 3000 A minimum rating. Will target 717 MVA normal and emergency ratings. Wormer Road and Molina stations will need to be expanded to accommodate greenfield circuit construction.
- Rebuild the 3.25-mile Wormser Road – Santo Nino 138 kV line to minimum of 2000 A capability. Will target 478 MVA normal and emergency ratings.
- Rebuild 19.8-mile North Laredo Switch – Unitec – Gateway East Tap 138 kV line to minimum of 3000 A capability. Will target 717 MVA normal and emergency ratings.
- Rebuild 6.9-mile University – Gateway West Tap 138 kV line to minimum of 3000 A capability. Will target 717 MVA normal and emergency ratings.
- Rebuild 1.37-mile Fincas – Gateway West Tap 138 kV line to minimum of 3000 A capability. Will target 717 MVA normal and emergency ratings.
- Rebuild 5.9-mile Fincas – Santo Nino 138 kV line to minimum of 3000 A capability. Will target 717 MVA normal and emergency ratings.
- Rebuild 3.4-mile Gateway East Tap – Wormser Road 138 kV line to minimum of 3000 A capability. Will target 717 MVA normal and emergency ratings.
- AEP to perform necessary station upgrades as to not limit any of the lines proposed for rebuild.

## Station Addition/Expansion

- Construct (2) 345/138 kV auto-transformers at Molina station. Expand Molina 138 kV yard. Expand Cenizo 345 kV. Terminate 138 kV side of transformation into Molina. Construct short 345 kV lines from high side of transformation to terminate at Cenizo station. Autotransformers will target 675 MVA minimum ratings. All other station equipment at Cenizo & Molina will target 5000 A for 345 kV equipment and 3000 A for 138 kV equipment.
- AEP to perform necessary station upgrades as to not limit any of the lines proposed for rebuild.

# Option 2

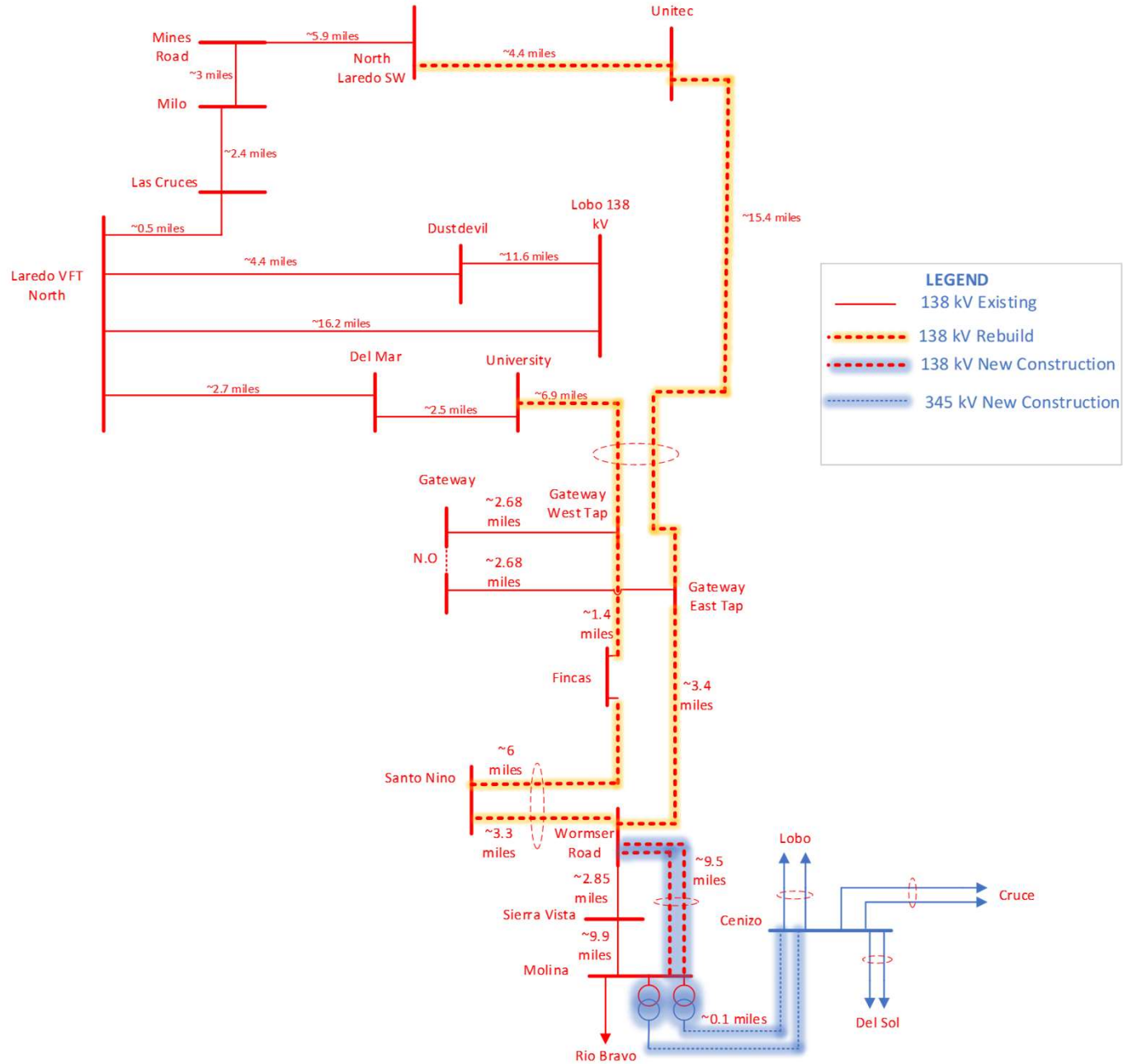

# Option 3

## Transmission Line Additions/Modifications

- Construct approximately 14.5-mile greenfield Lobo – Wormser Road 138 kV line. Line will be designed/constructed to 3000 A minimum rating. Will target 717 MVA normal and emergency ratings.
- Rebuild the 3.25-mile Wormser Road – Santo Nino 138 kV line to minimum of 2000 A capability. Will target 478 MVA normal and emergency ratings.
- Rebuild 19.8-mile North Laredo Switch – Unitec – Gateway West Tap 138 kV line to minimum of 3000 A capability. Will target 717 MVA normal and emergency ratings.
- Rebuild 1.37-mile Fincas – Gateway West Tap 138 kV line to minimum of 3000 A capability. Will target 717 MVA normal and emergency ratings.
- Rebuild 6-mile Fincas – Santo Nino 138 kV line to minimum of 3000 A capability. Will target 717 MVA normal and emergency ratings.
- Rebuild 3.4 miles Gateway East Tap – Wormser Road 138 kV line to minimum of 3000 A capability. Will target 717 MVA normal and emergency ratings.

## Station Addition/Expansion

- Expand Wormser Road & Lobo 138 kV stations to accommodate terminal for proposed greenfield line
- AEP to perform necessary station upgrades as to not limit any of the lines proposed for rebuild.

# Option 3

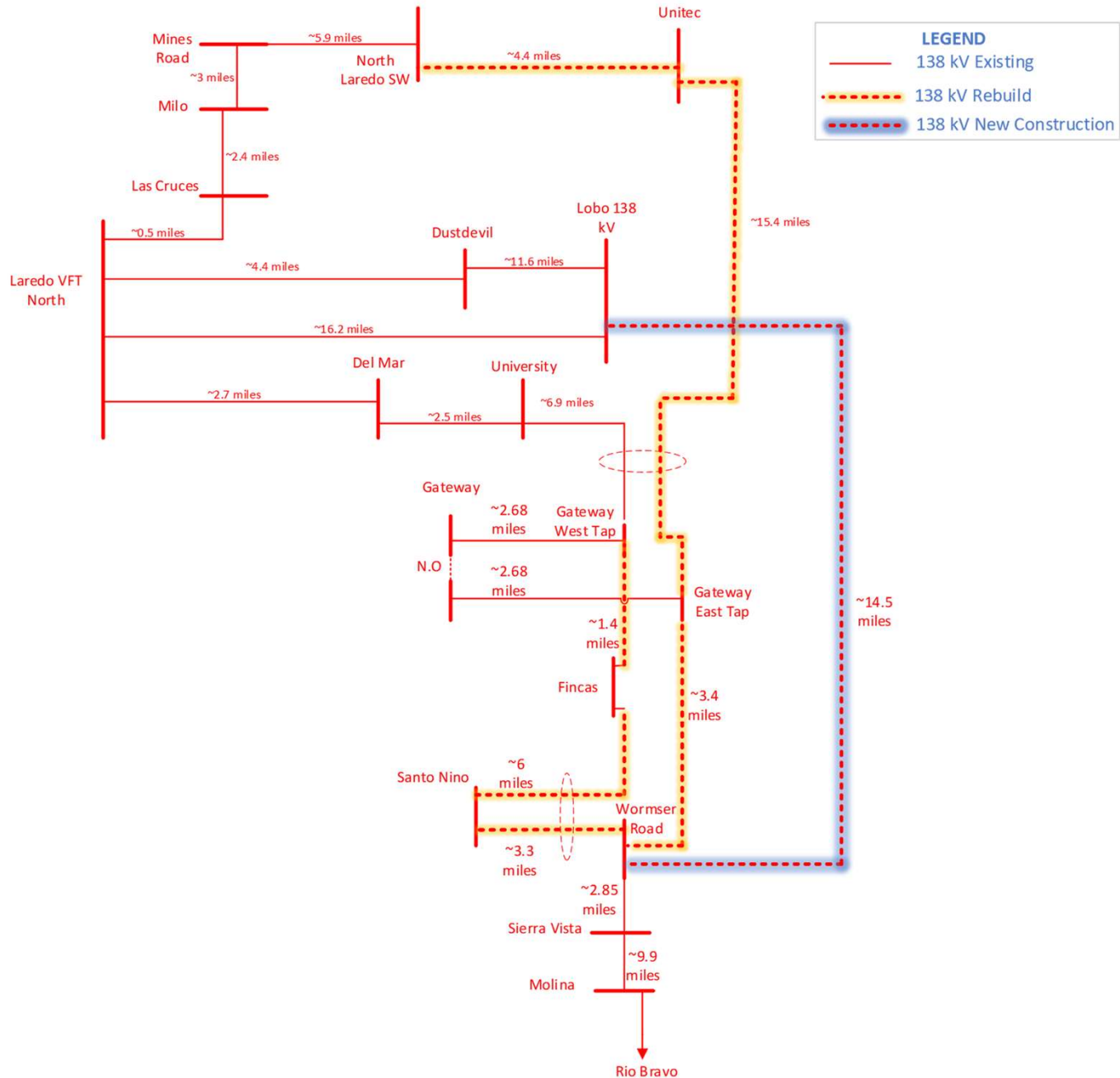

# Study Assumptions – Steady State

- ERCOT 2024 SSWG Cases were used in assessment. 2028 HRML and 2029 Summer on peak cases used in steady state analysis.
- Verified status of 6.9 compliant generation in both cases. 6.9 compliant at time of case build process.
- Verified study area projects using June and October 2025 TPIT information.

## Contingency Criteria

Type	NERC Category	Description
N-0	P0	Transmission system operating under normal conditions with zero facilities out of service.
N-1	P1, P2.1, P7	Transmission system operating with a forced outage of a single line, transformer, generator, or switched shunt. ERCOT criteria consider double circuit lines greater than one ½ mile a single outage.
N-A-1	P6.2 / ERCOT 3	Transmission system operating with an outage of a single 345 kV autotransformer followed by a forced outage of a single circuit, transformer, or switched shunt.
N-G-1	P3/ERCOT 2	Transmission system operating with an outage of a single generating unit followed by a forced outage of a single line, transformer, generator, or switched shunt.
N-1-1	P6	Transmission system operating with a planned maintenance outage of a single circuit, transformer, or switched shunt followed by a forced outage of a single circuit, transformer, or switched shunt.
N-X	P4, P5	Single breaker failure and delayed clearing of non-redundant relays were considered for EHV.
Maint + Outage	P6, P1+P7 / P7+P7	ERCOT maintenance outage reliability criteria

# Steady State Results

Contingency Category	No Upgrades	Option 1	Option 2	Option 3 (Preferred Solution)*
P0	No Violations	No Violations	No Violations	No Violations
P1,P2.1, P7	3 Thermal Violations, Vdelta > 8% identified, 2 Non-Converged.	No Violations	No Violations	No Violations
P2.2,P2.3, P4	3 Thermal Issues, 2 Low Voltages, 1 Non-Converged.	4 Thermal Issues	No Violations	No Violations
P3	8 Thermal Violations, >20 Low Voltages, Multiple Non-Converged.	5 Thermal Violations.	No Violations	No Violations
P5	8 Thermal Violations, 4 Low Voltages.	5 Thermal Violations.	No Violations	No Violations
P6.2	3 Thermal Violations, Multiple Non-Converged.	1 Thermal Violation.	No Violations	No Violations
P6.1 (OFF-PEAK); P1+P7 / P7+P7	6 Non-Converged, >20 High Voltage, 2 Vlows.	No Violations	No Violations	No Violations

# Dynamic Analysis Assumptions

- Dynamic stability analysis was carried out using ERCOT DWG 2028 HRML and 2031 SP cases to evaluate dynamic performance of the Laredo area upgrades for preferred option 3. Effects of the system upgrades on the surrounding transmission system were also evaluated.

## Initial Assumptions

- A case comparison between DWG 2031 SP and SSWG 2029 SP in the Laredo area was conducted, and no significant differences were identified.
- Added the Seven Flags BESS at 8295 Wormser 138 kV station in 2031 SP case.
- Added 70 MW load at 8612 Reveille4A to reflect Navitas load. Zip load model is used to model Navitas load.
- Added CMLD data center dynamic load model to Cinco 1 &2 at 8962 Lytle4A.
- Ratings of Laredo VFT North – Las Cruces – Milo – Mines Road – North Laredo SW 138 kV are rebuilt to 2000 amps.
- Construct ~17-mile greenfield circuit from Lobo – Wormser 138 kV. Construct double circuit structures but only one circuit strung initially.
- Rebuild Wormser Road – Santo Nino 138 kV. 2000 A minimum.
- Rebuild North Laredo – Unitec – Gateway Tap 138 kV. 3000 A minimum.
- Rebuild Fincas – Gateway Tap 138 kV. 2000 A minimum.
- Rebuild Fincas – Santa Nino. 2000 A minimum
- Rebuild Gateway Tap – Wormser 138 kV. 3000 A minimum

# Dynamic Analysis Results

- The dynamic stability analysis revealed that no stability violations in the 2028 HRML and 2031 SP scenarios were observed under the studied P1, P4, P6 and P7 conditions.

# Short Circuit

---

- Short Circuit Analysis was conducted on 2029 FY ERCOT SPWG (System Protection Working Group) case.
- Devices/buses contained in zone 635 (LAREDO)
- No fault duty exceedances identified for any of the facilities included in study area. This applies to the base case as well as any of the proposed solution sets.

# Option Comparison

Option	138 kV rebuild mileage	138 kV greenfield mileage	Dynamic Reactive
1	~31 Miles	0	+/- 300 MVAR
2	~41 Miles	9.5 Miles	0
3	~34 Miles	14.5 Miles	0

Option	Projected Costs
1	\$230 M
2	\$245 M
3	\$178 M

# Recommendation

---

- AEPSC Recommends Option 3 due to being least cost option and mitigating all identified violations under criteria studied.
- Option 3 has a projected cost of \$178 million dollars and has estimated in service date of September 2029.