



Real-Time Market Operations



2026_04 Real-Time Market Operations



Greetings
and
Introductions

Attendance

Questions

Presentation Materials



PROTOCOL DISCLAIMER

This presentation provides a general overview of the Texas Nodal Market and is not intended to be a substitute for the ERCOT Protocols, as amended from time to time. If any conflict exists between this presentation and the ERCOT Protocols, the ERCOT Protocols shall control in all respects.

For more information, please visit:

<http://www.ercot.com/mktrules/nprotocols/>

Format	Title
WBT	Wholesale Markets Overview

Format	Title	Topic
ILT	Day-Ahead Market Operations	Inputs
		Market Clearing
		Financial Impacts
	Reliability Unit Commitment	Overview
		Process
		Financial Impacts
	Real-Time Market Operations	Security Constrained Economic Dispatch
		Load Frequency Control
		Financial Impacts

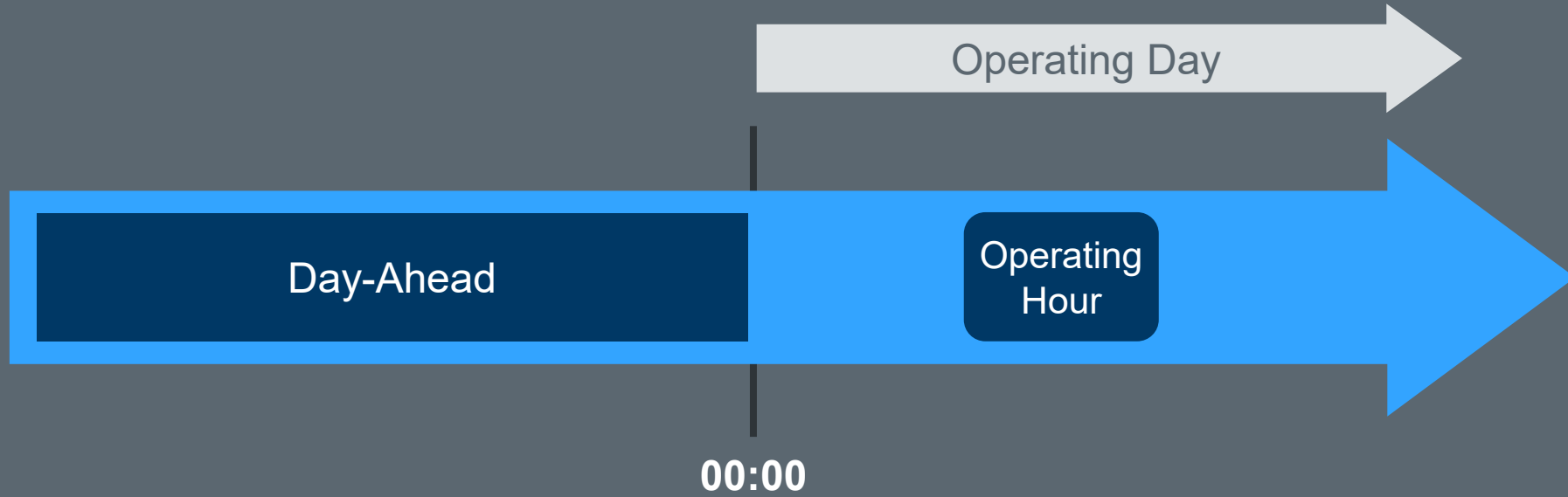

**Security Constrained
Economic Dispatch**



**Five-minute
Awards**

**Five-minute
Prices**

Load Frequency Control

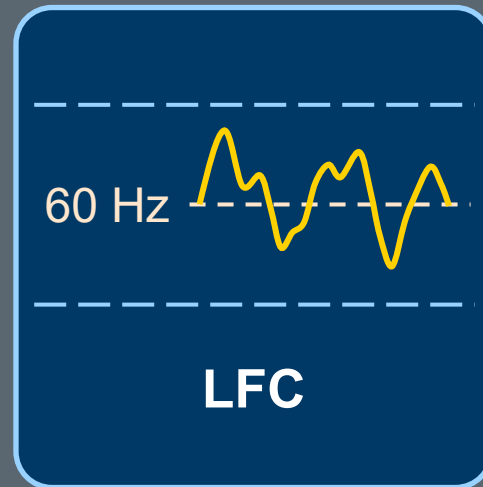

**Regulation
Service**

**Updated Desired
Set Point**



Security Constrained Economic Dispatch

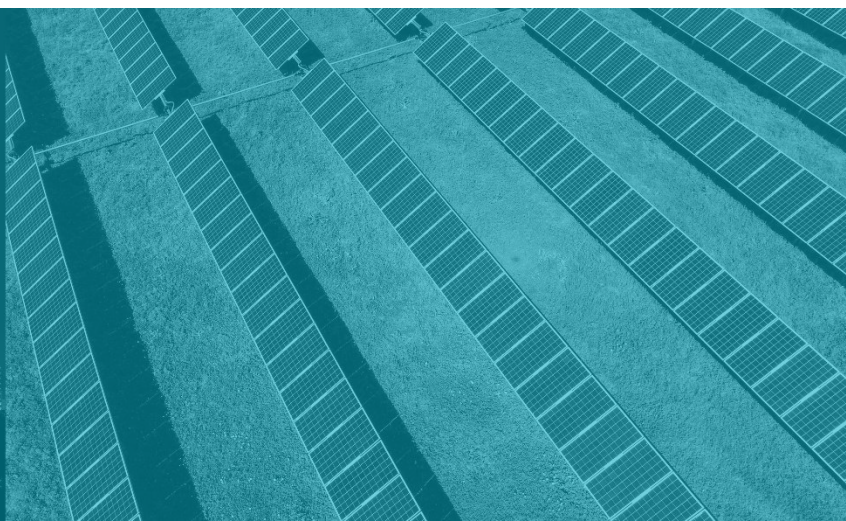

Balancing Reliability and Economics



SCED

In accordance with PUCT Scarcity Pricing Mechanism,

ERCOT Market Caps		HCAP	LCAP*
Day-Ahead System Wide Offer Cap	DASWCAP	\$5000	\$2000
Real-Time System Wide Offer Cap	RTSWCAP	\$2000	\$2000
Value of Lost Load	VOLL	DASWCAP	

* Used when Peaker Net Margin exceeds annual threshold

SCED Inputs

Manages Reliability at Least Cost

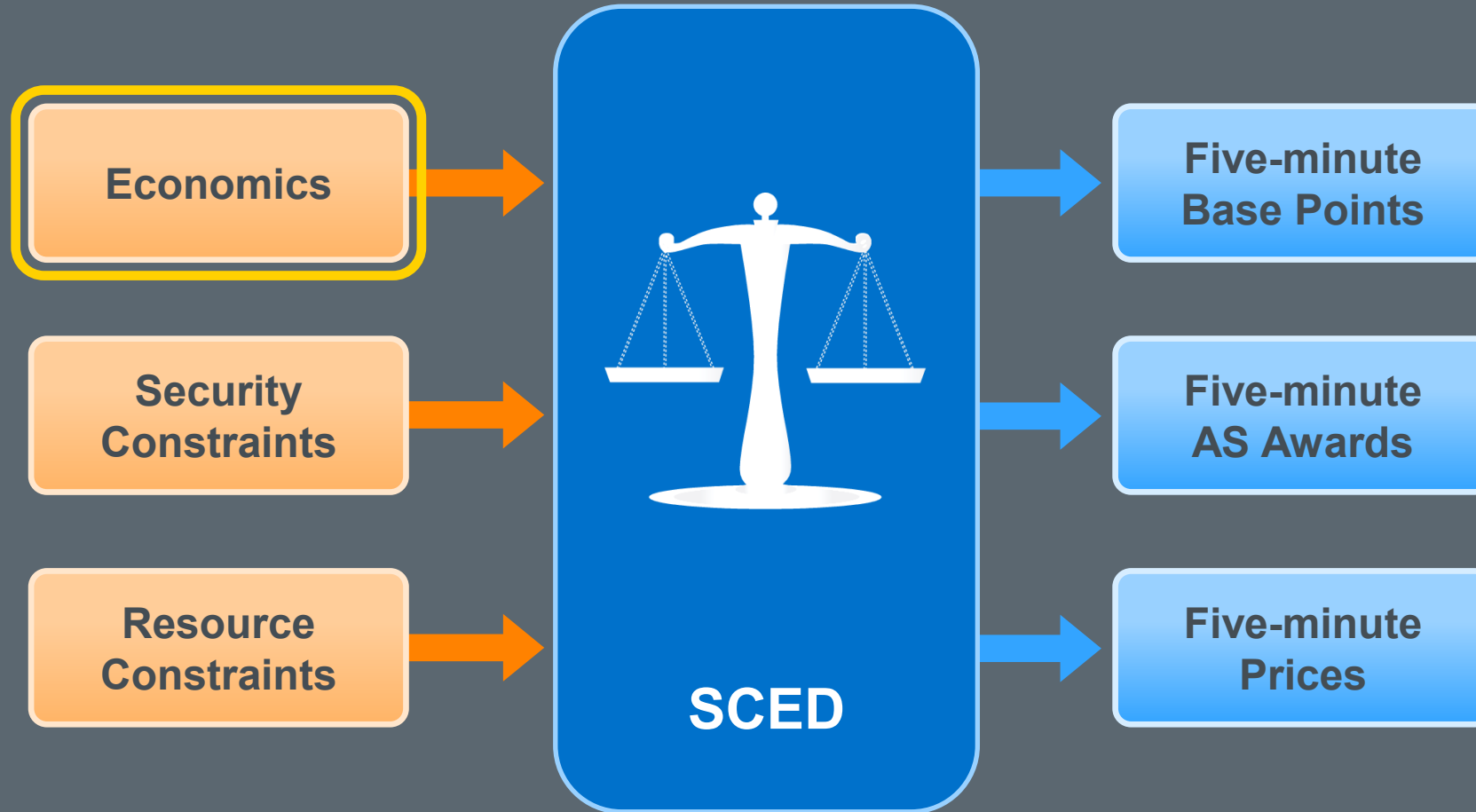

May be updated during any time before SCED

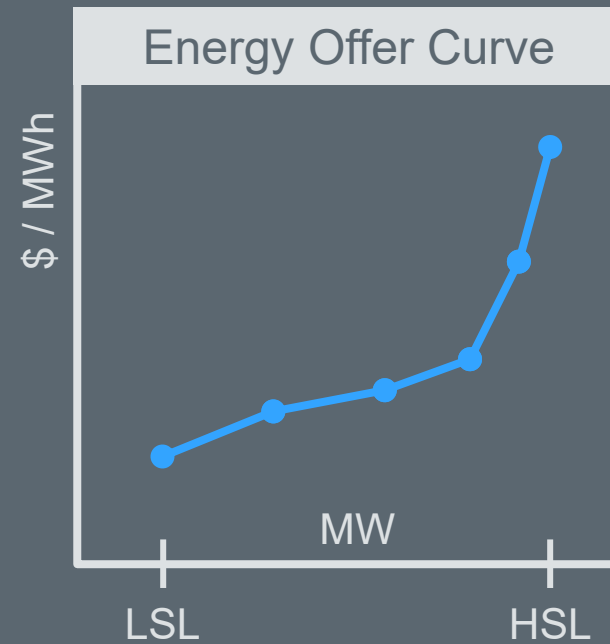
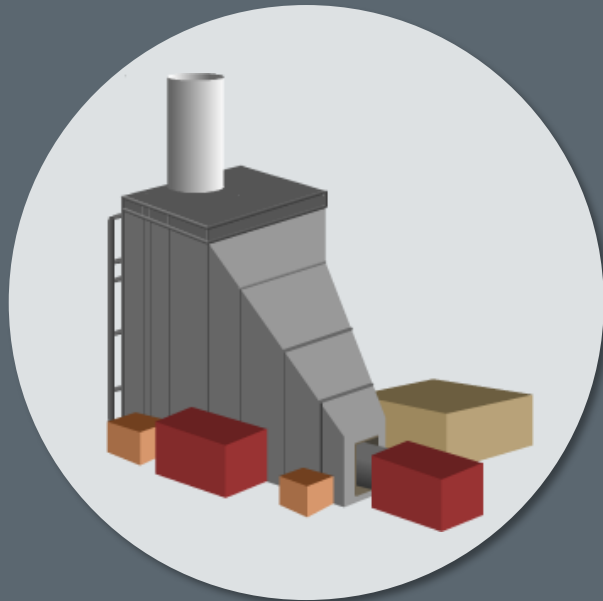

HSL = High Sustained Limit
LSL = Low Sustained Limit

May be updated during any time before SCED

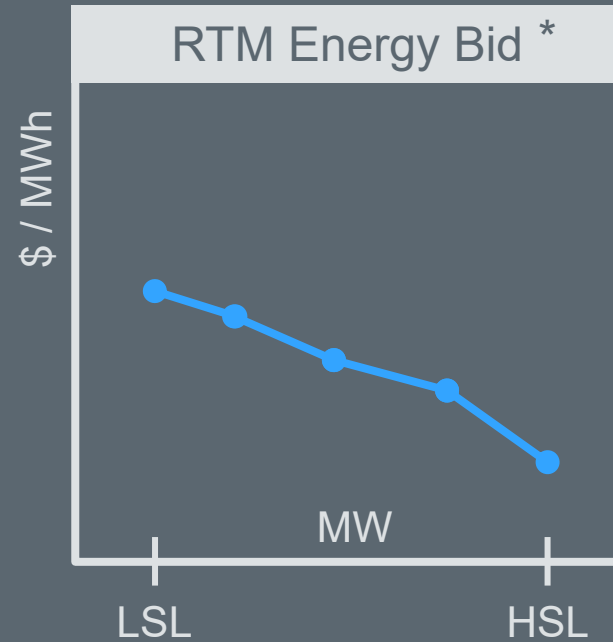

HSL = High Sustained Limit
LSL = Low Sustained Limit

* Capped at VOLL



May be updated during any time before SCED

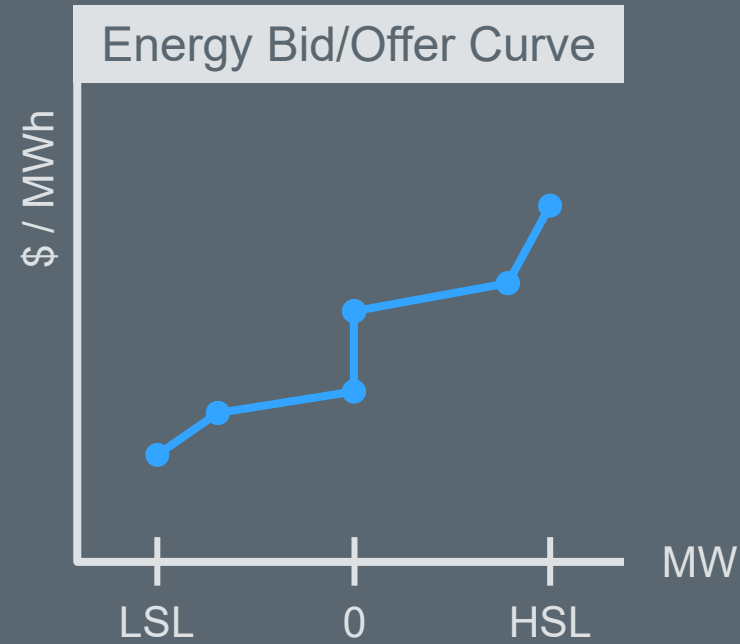

HSL = High Sustained Limit
LSL = Low Sustained Limit

May be updated during any time before SCED

Resource-specific offer for each qualified AS Type

ERCOT creates proxy offers for each qualified Resource not offered by QSE

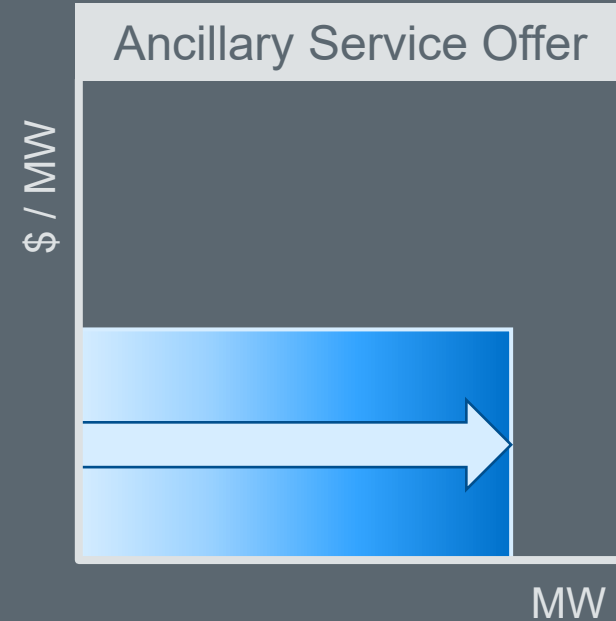

Solves Power Balance and Transmission Constraints

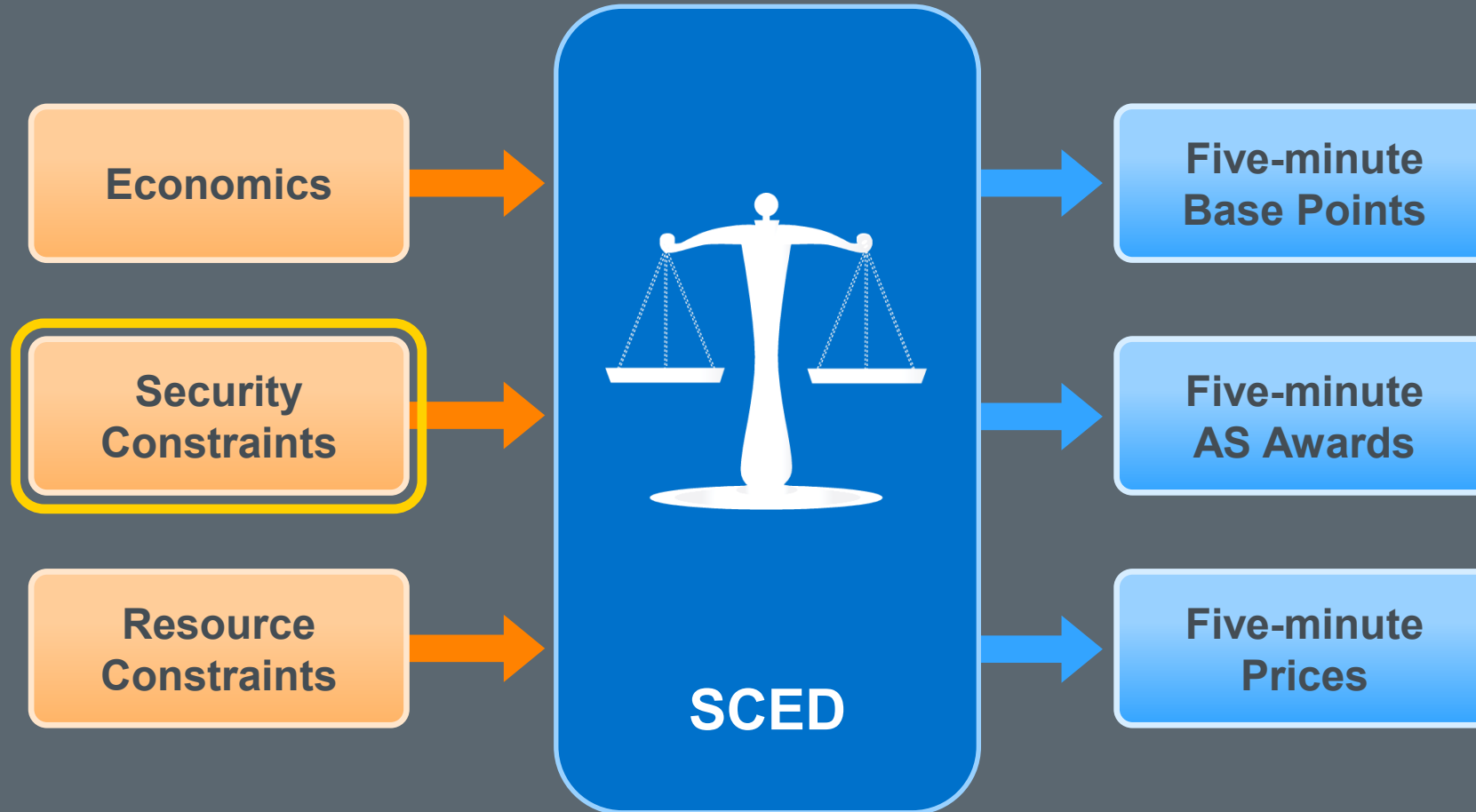

Security Analysis before each SCED cycle

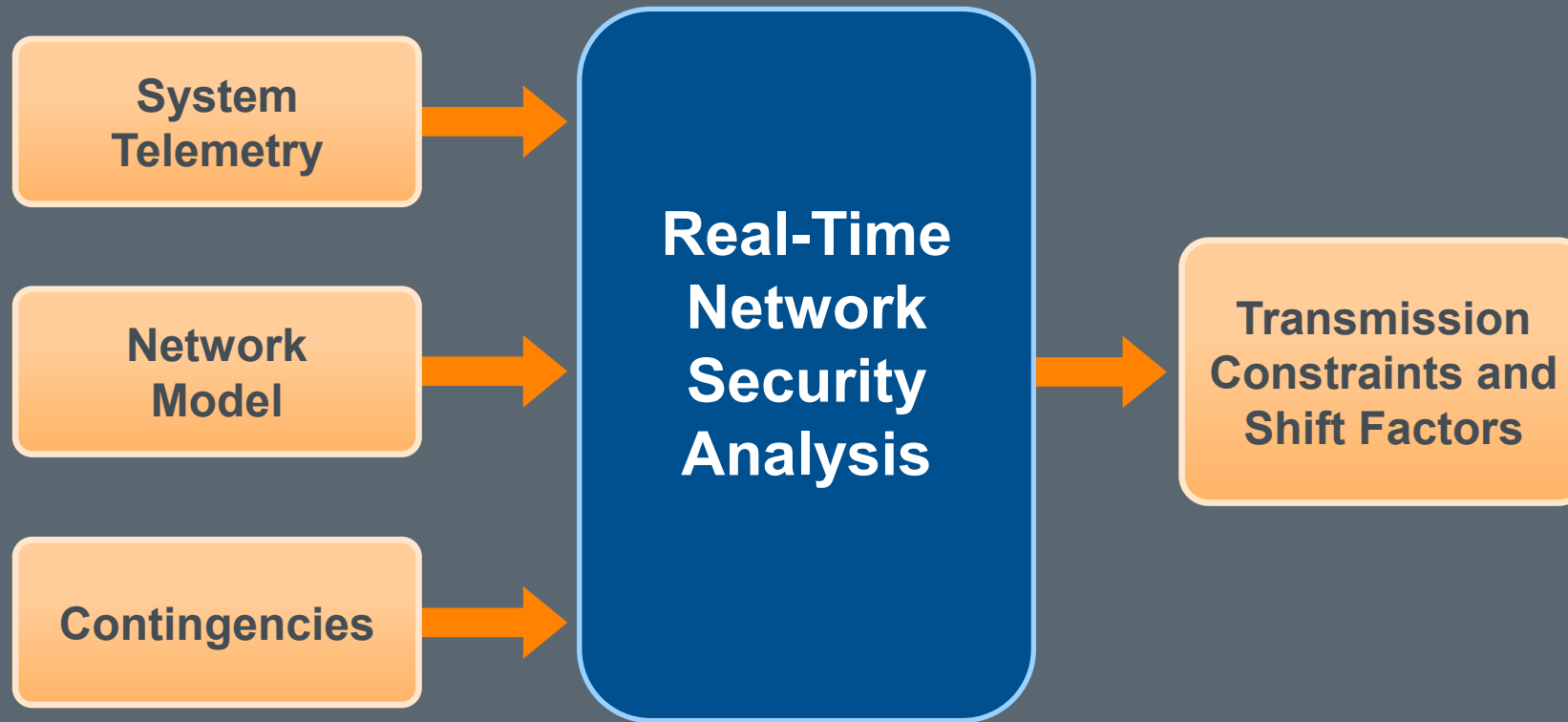

How Resources impact a Transmission Constraint

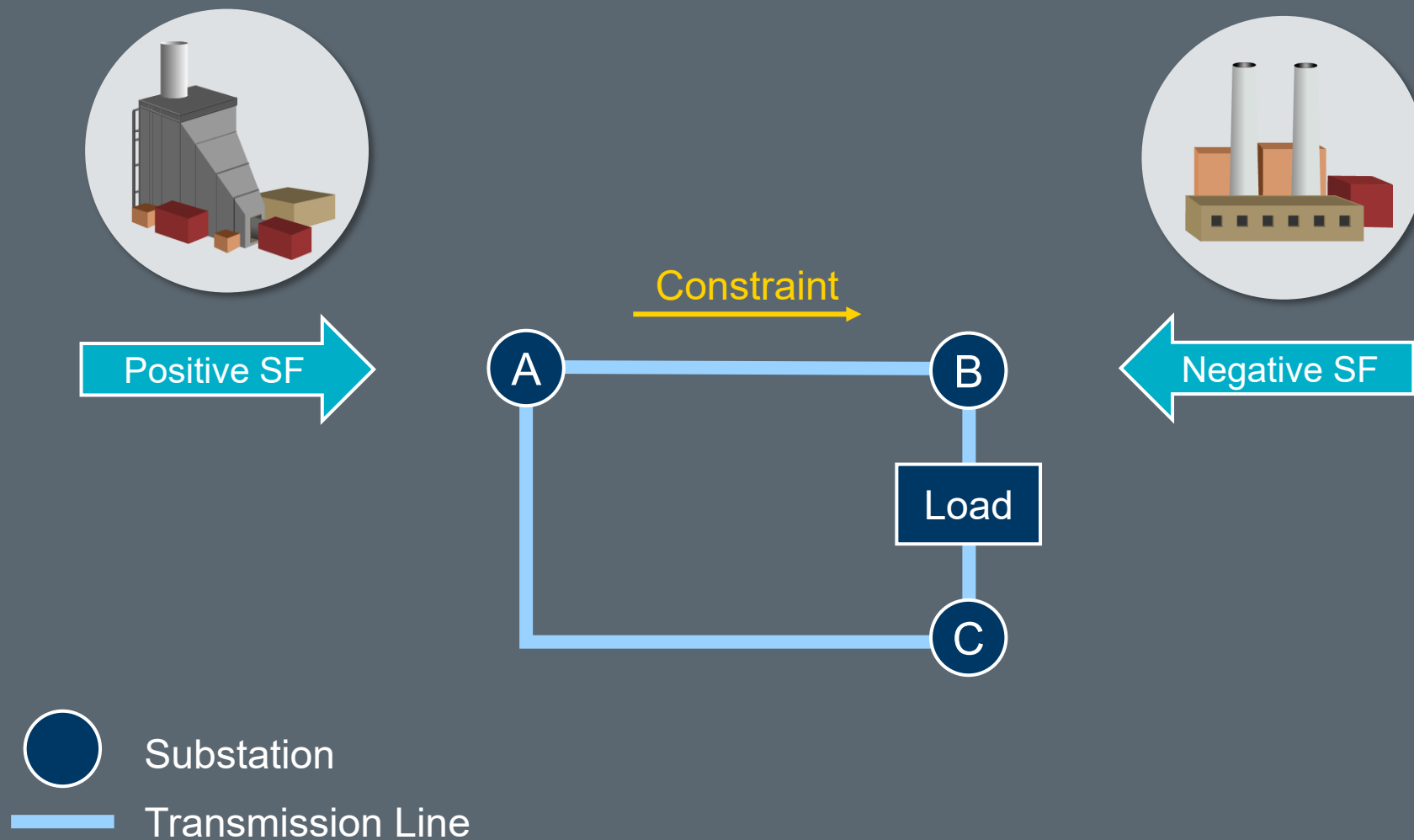

Observes Resource capabilities when dispatching

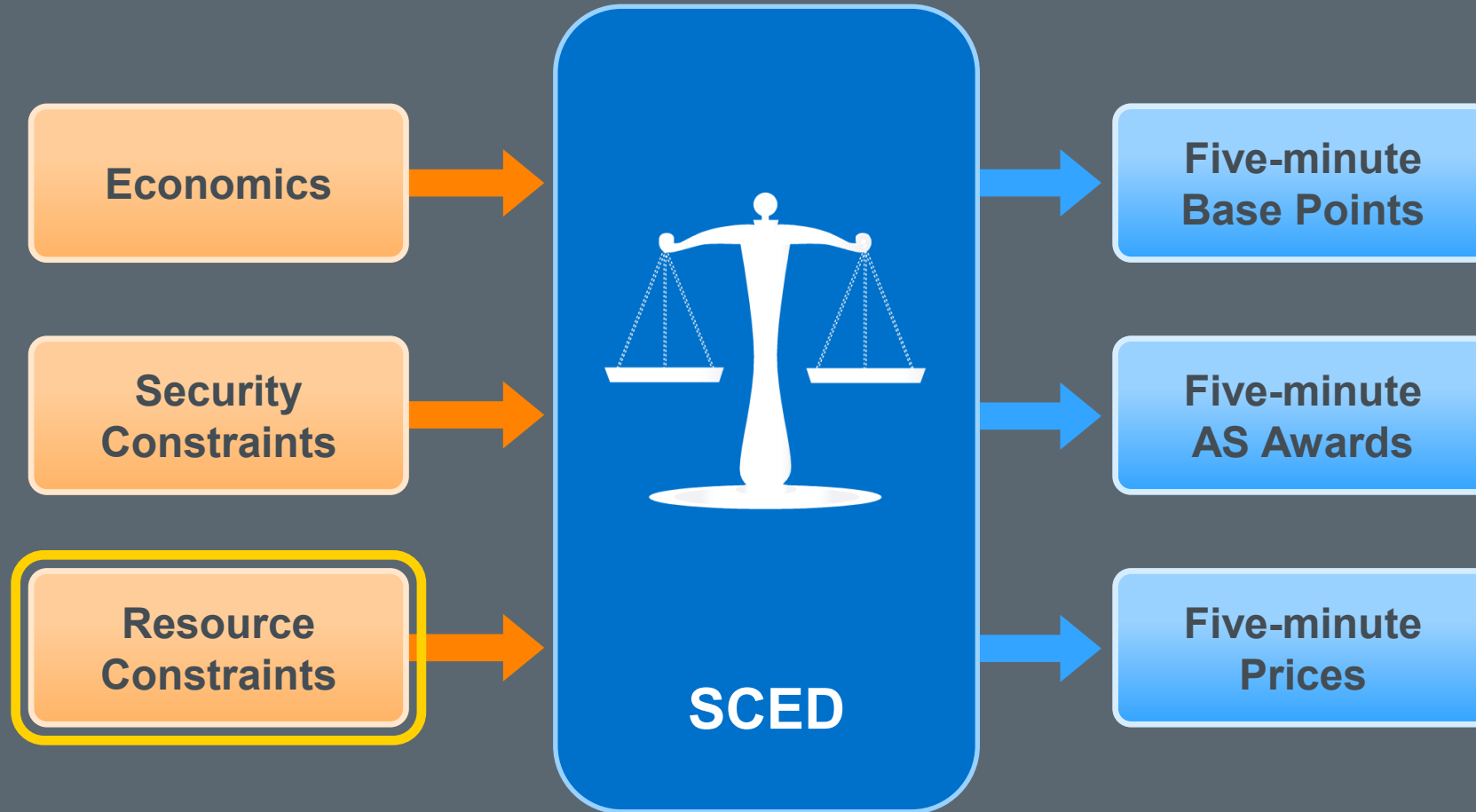

High Sustained Limit

Telemetered by the QSE every few seconds

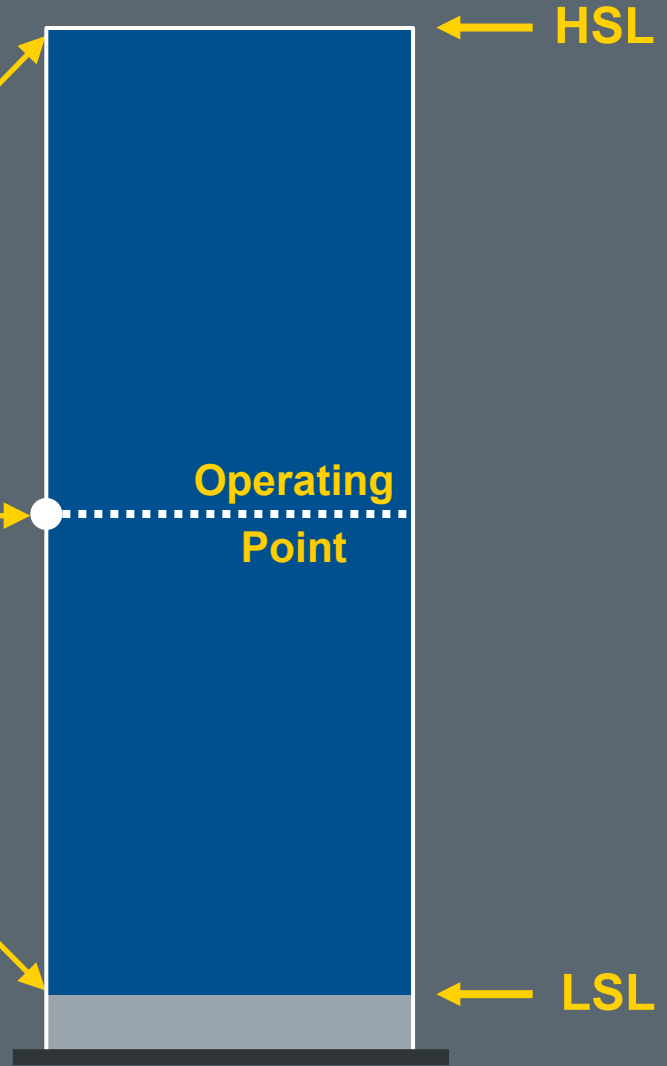

Low Sustained Limit

Ancillary Service Capabilities

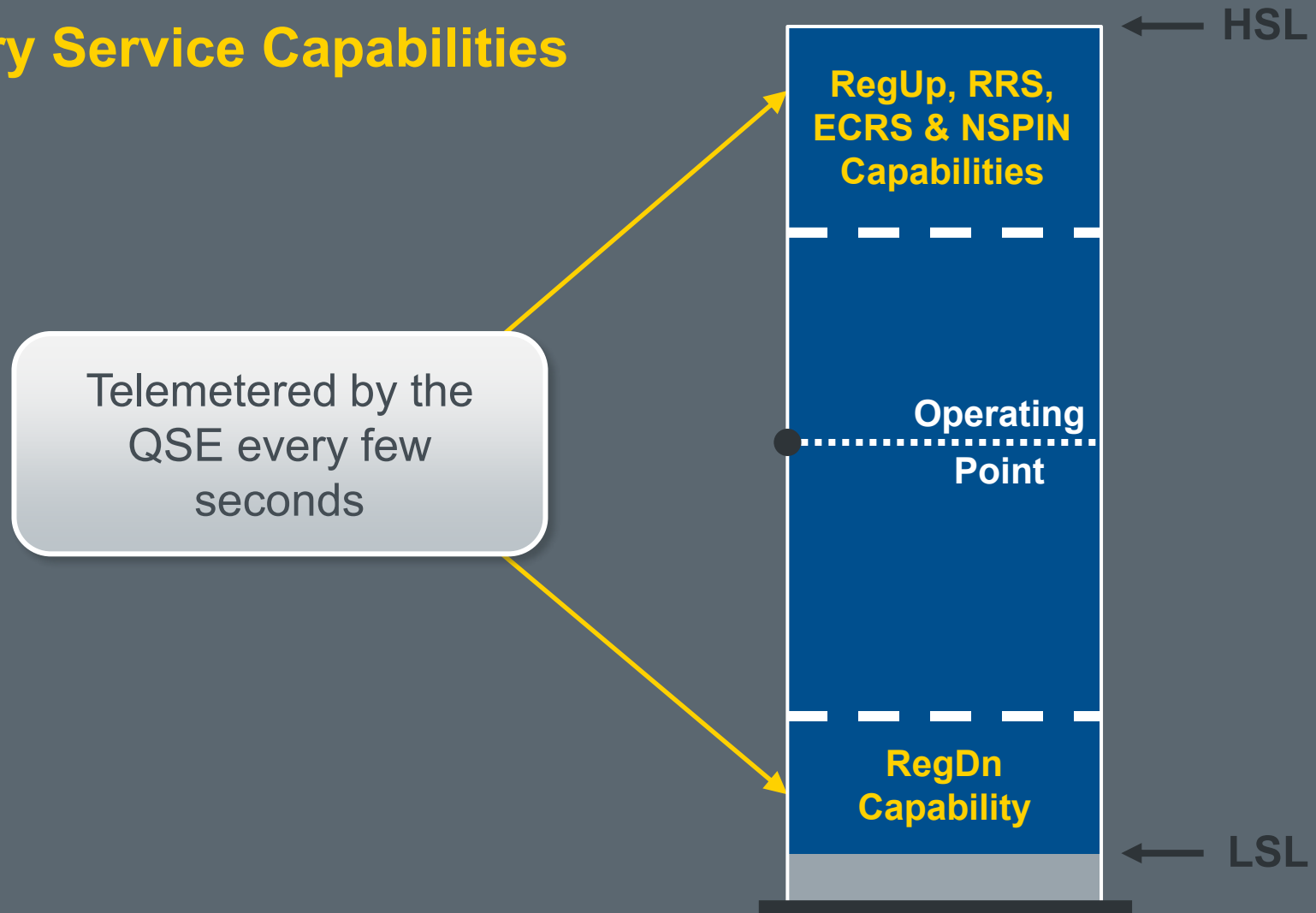

High Dispatch Limit

$$\text{Base Point} + (5/7) \text{ RegUp Award} \leq \text{HDL}$$

$$\text{Base Point} - (5/7) \text{ RegDn Award} \geq \text{LDL}$$

Low Dispatch Limit

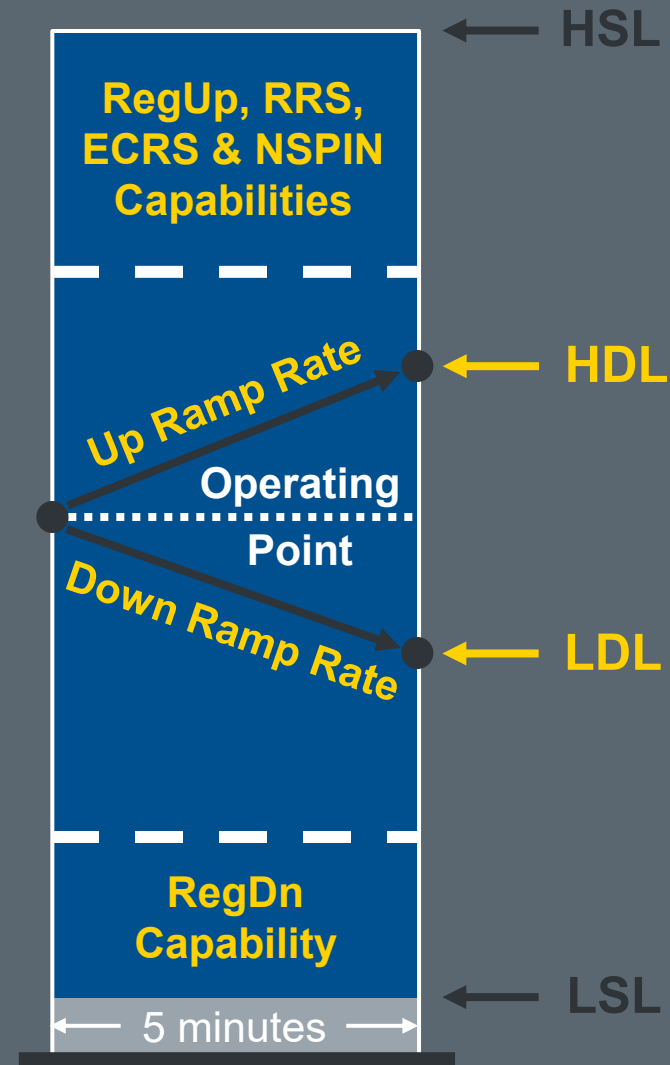

Resource Limit Calculator

$$\text{Base Point} + \text{RegUp Award} + \text{RRS Award} + \text{ECRS Award} + \text{NSPIN Award} \leq \text{HSL}$$

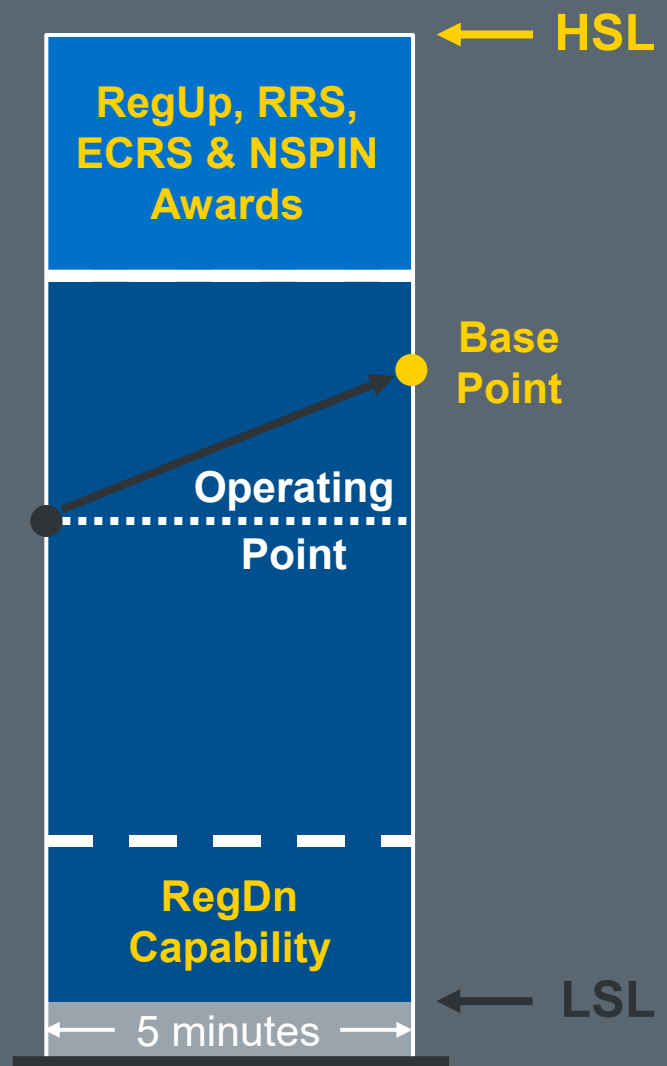

High Dispatch Limit

Low Dispatch Limit

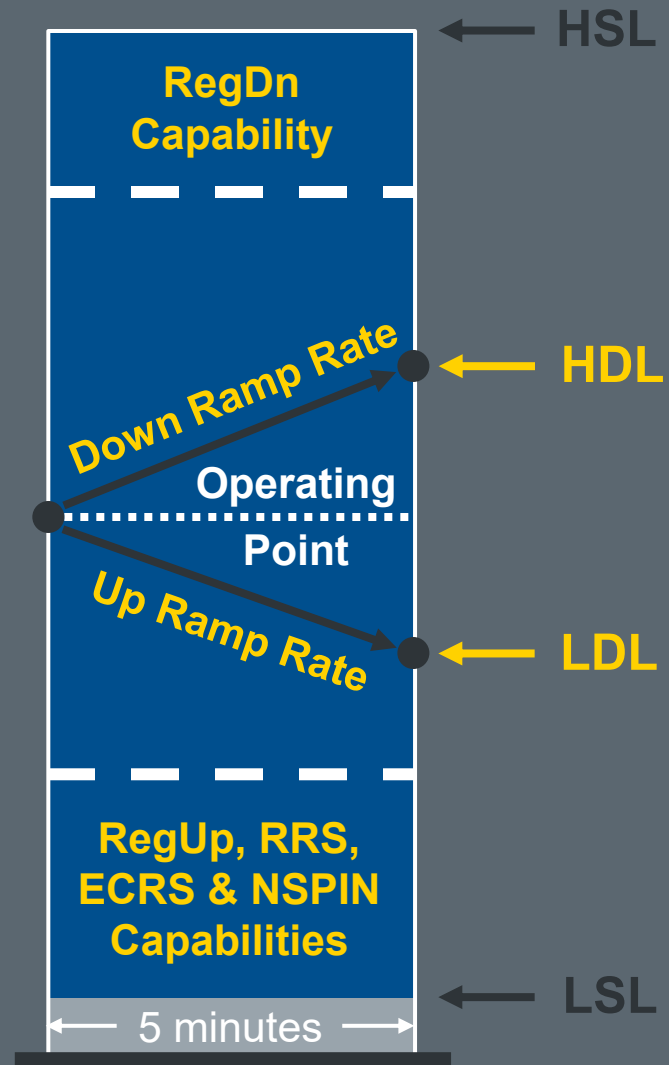

Resource Limit Calculator



Ancillary Service awards have duration constraints



Ancillary Service	Duration
RegUp	30 minutes
RegDn	30 minutes
RRS	Depends
ECRS	1 hour
Non-Spin	4 hours

... calculated from State-of-Charge Telemetry

SCED Process

So what does SCED do with all this stuff?

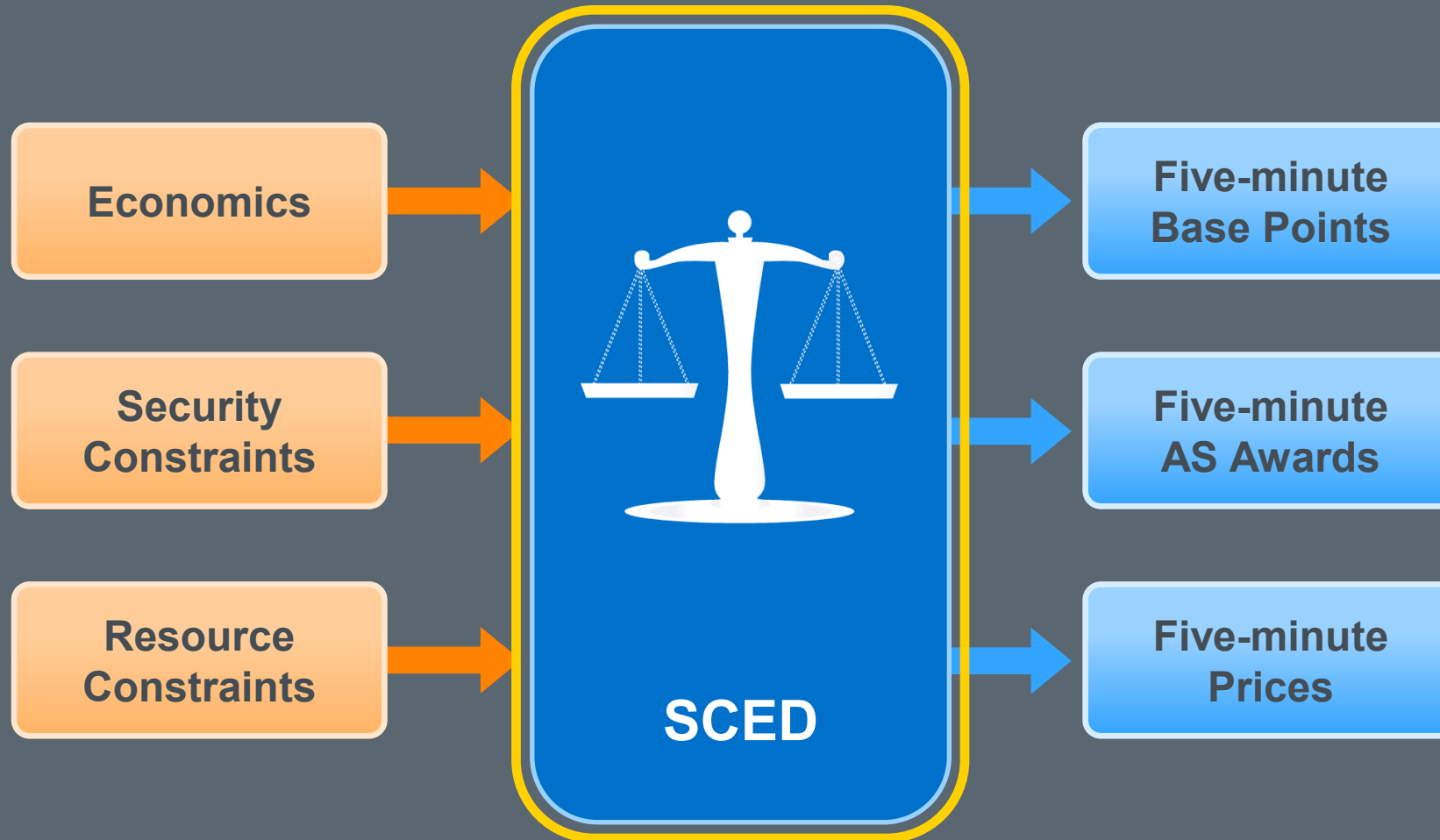

The Texas Two Step





SCED executes twice each cycle

- Reduces Market Power
- Allows high prices under the right circumstances

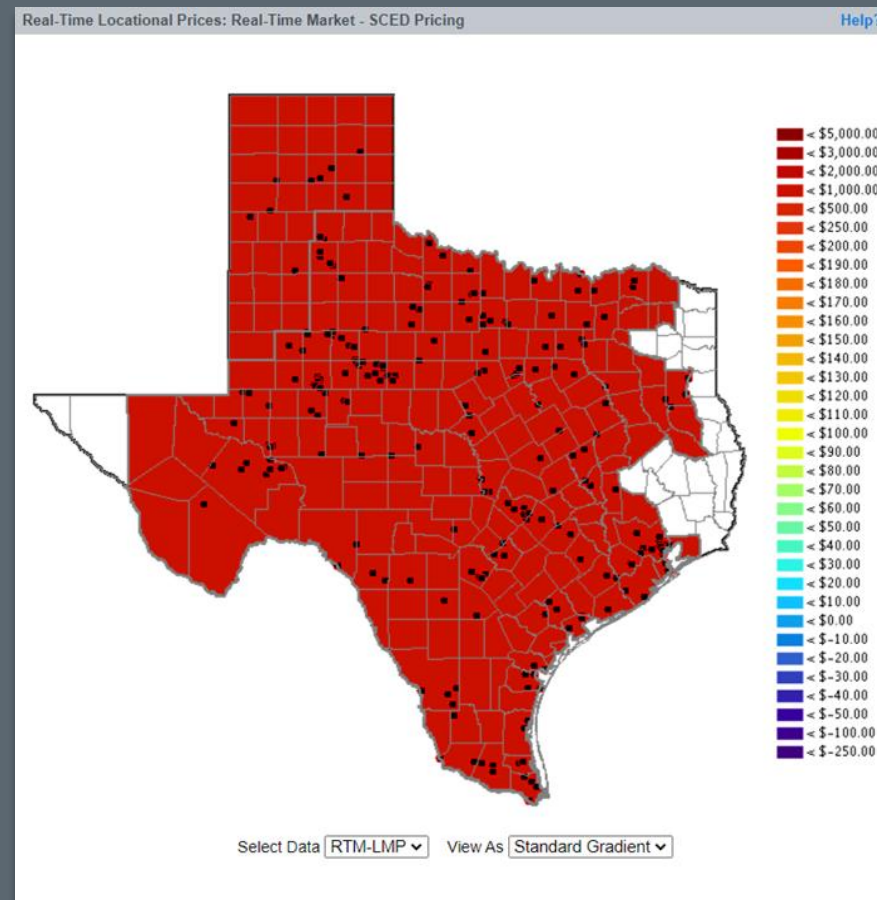
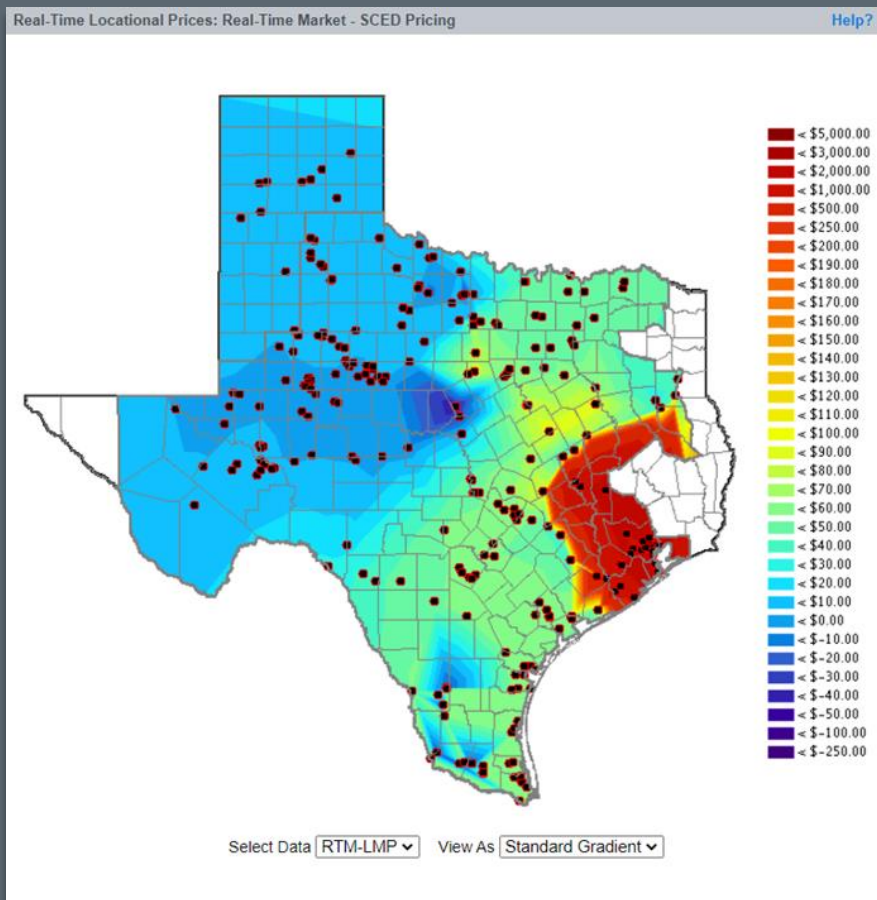

Transmission Constraints must be classified*



Competitive?
-- or --
Non-Competitive?

*See Protocol Section 3.19.4 for details

Step One

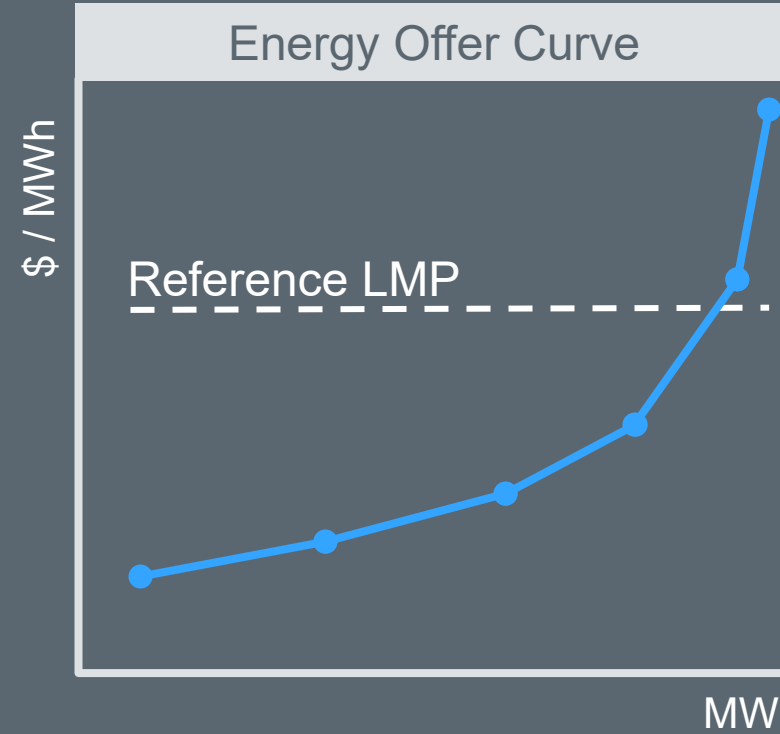

Step Two

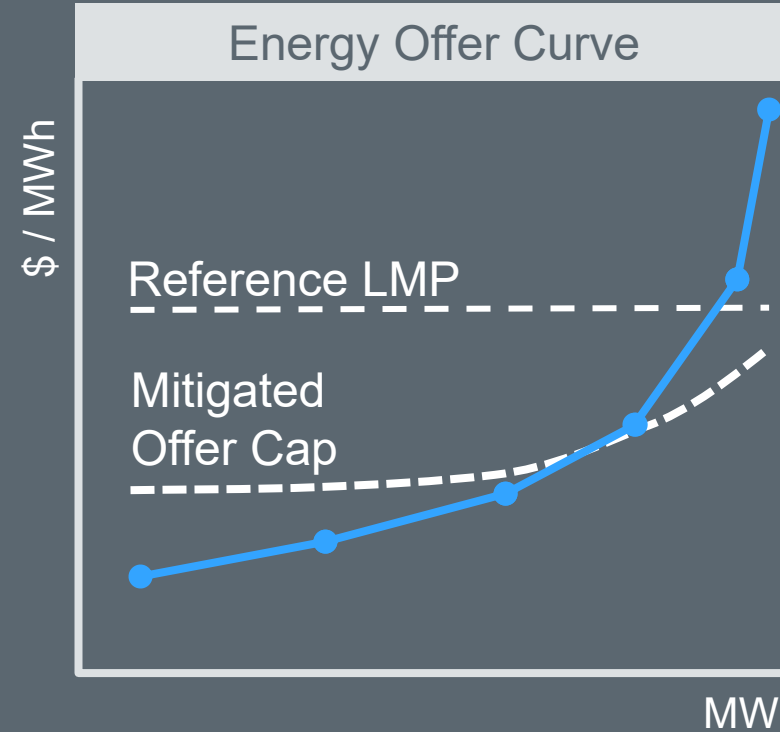

Capped at greater of Reference LMP or Mitigated Offer Cap



SCED has completed Step One

How will this Energy Offer Curve look in STEP Two?

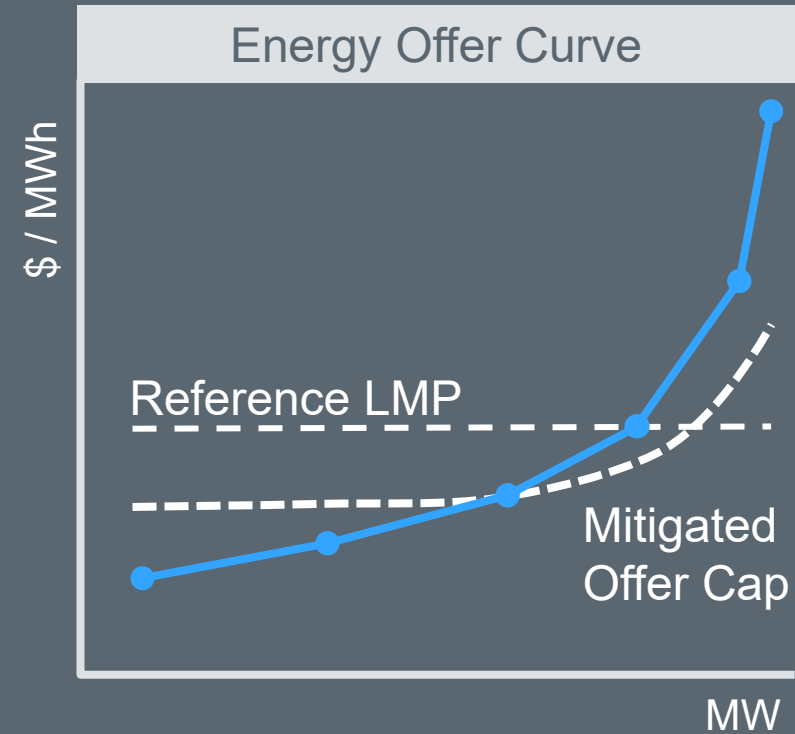



SCED has completed Step One

How will this Energy Offer Curve look in STEP Two?

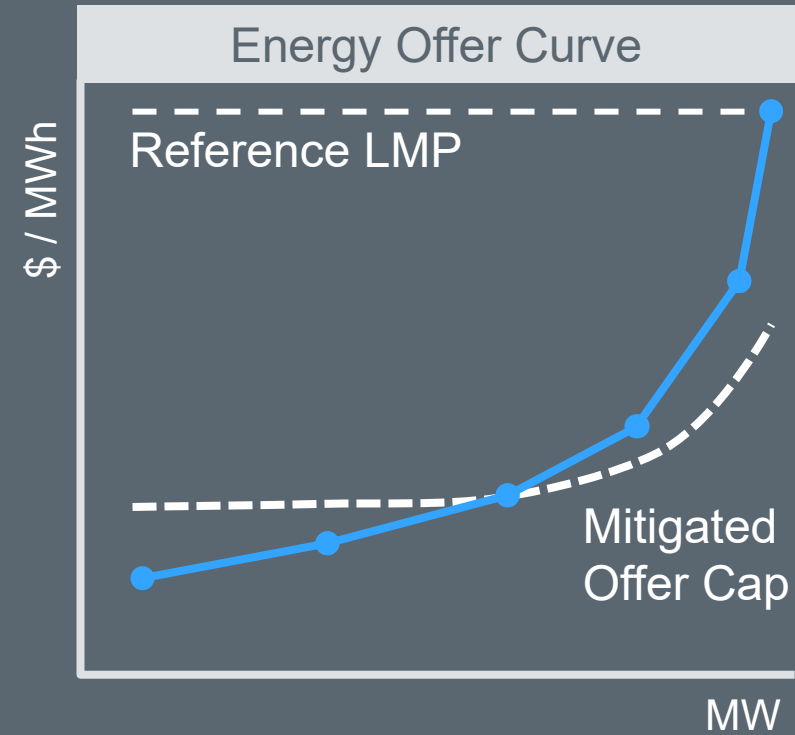

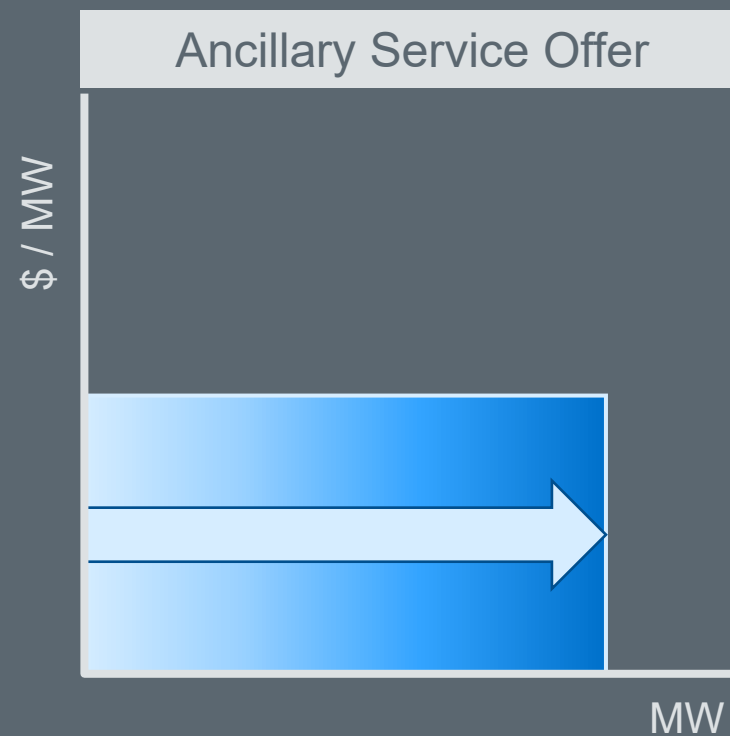

SCED Results

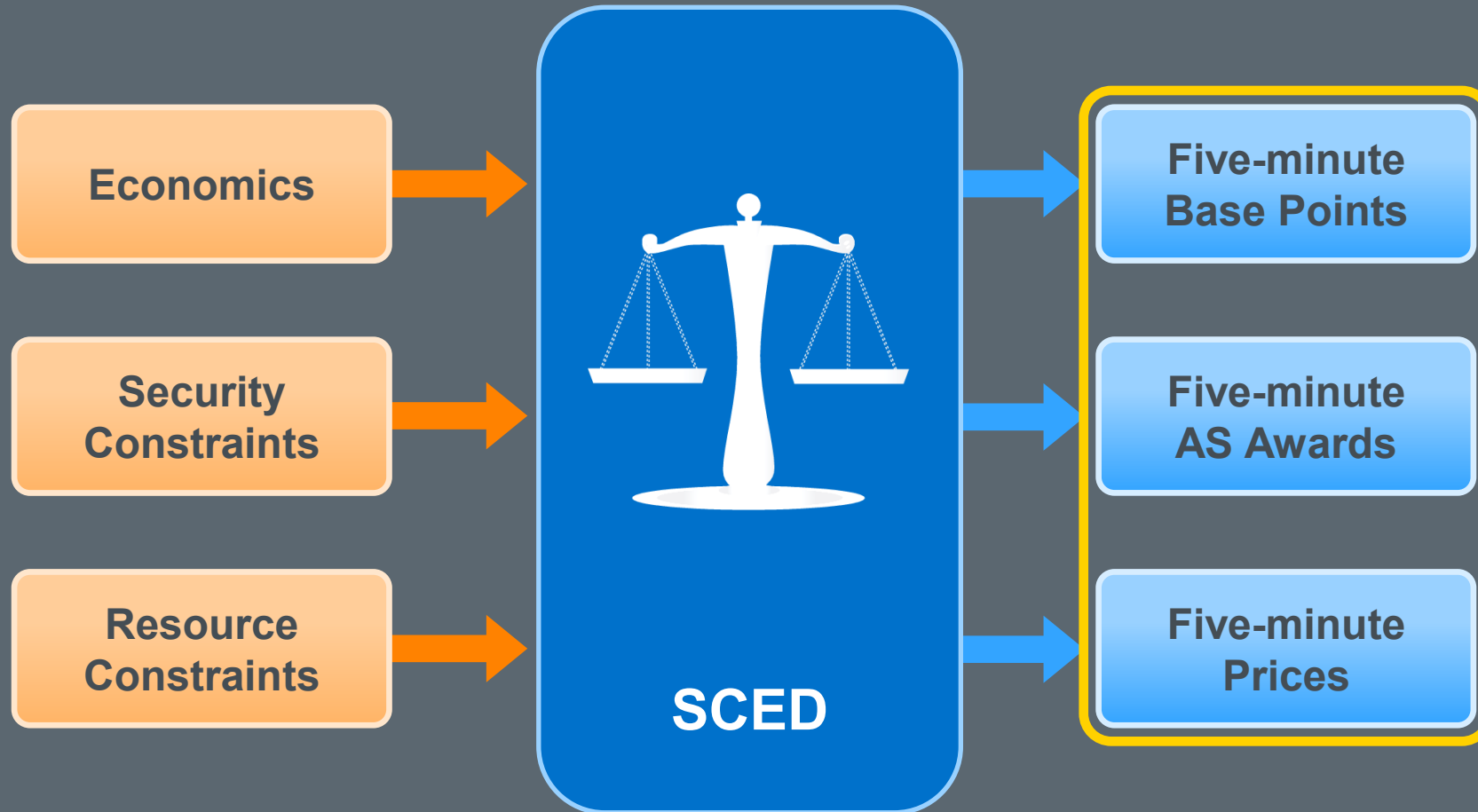

Base Points, AS Awards and prices sent to QSEs



ICCP = Inter-Control Center Protocol

AS Type	Deployment Methodology
ERCOT Contingency Reserve Service	SCED
On-line Non-Spin	SCED
Off-line Non-Spin	Operator Dispatch Instruction
Regulation Up and Regulation Down	Load Frequency Control
Responsive Reserve Service	Frequency Trigger



Reserves are managed by SCED

1. *SCED needs more energy*
2. *Converts AS into Energy*
 - *Less AS Award*
 - *New Base Point*
3. *Which AS does it choose?*

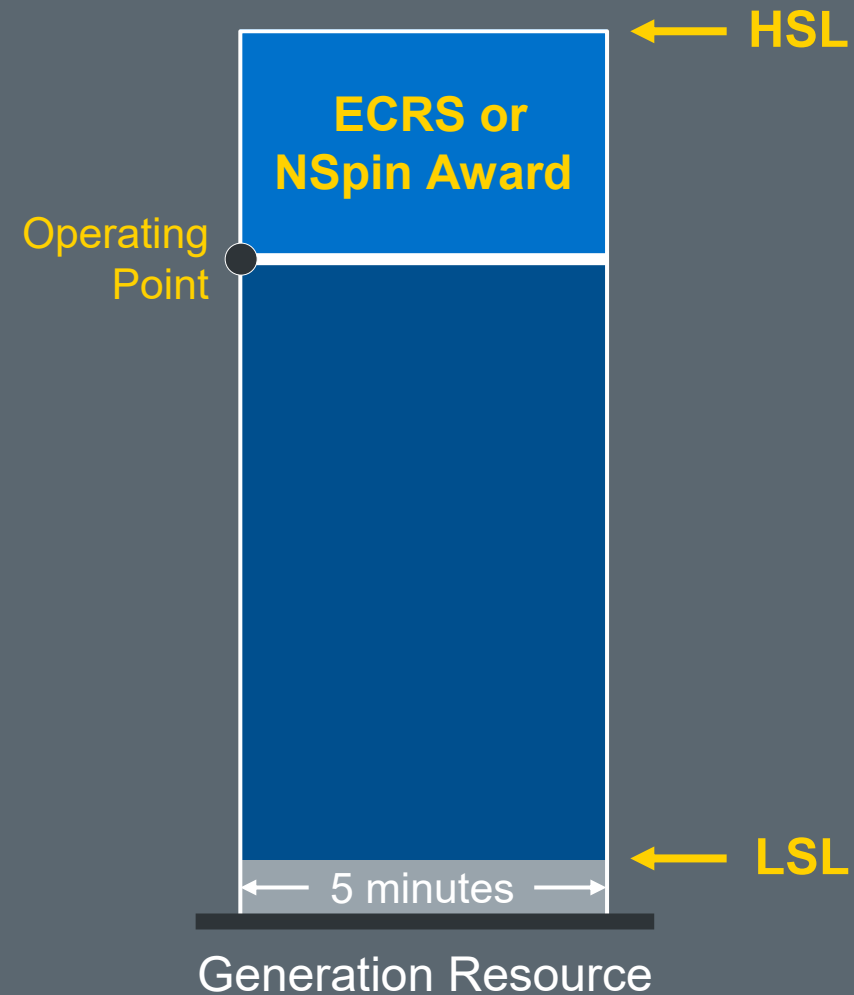

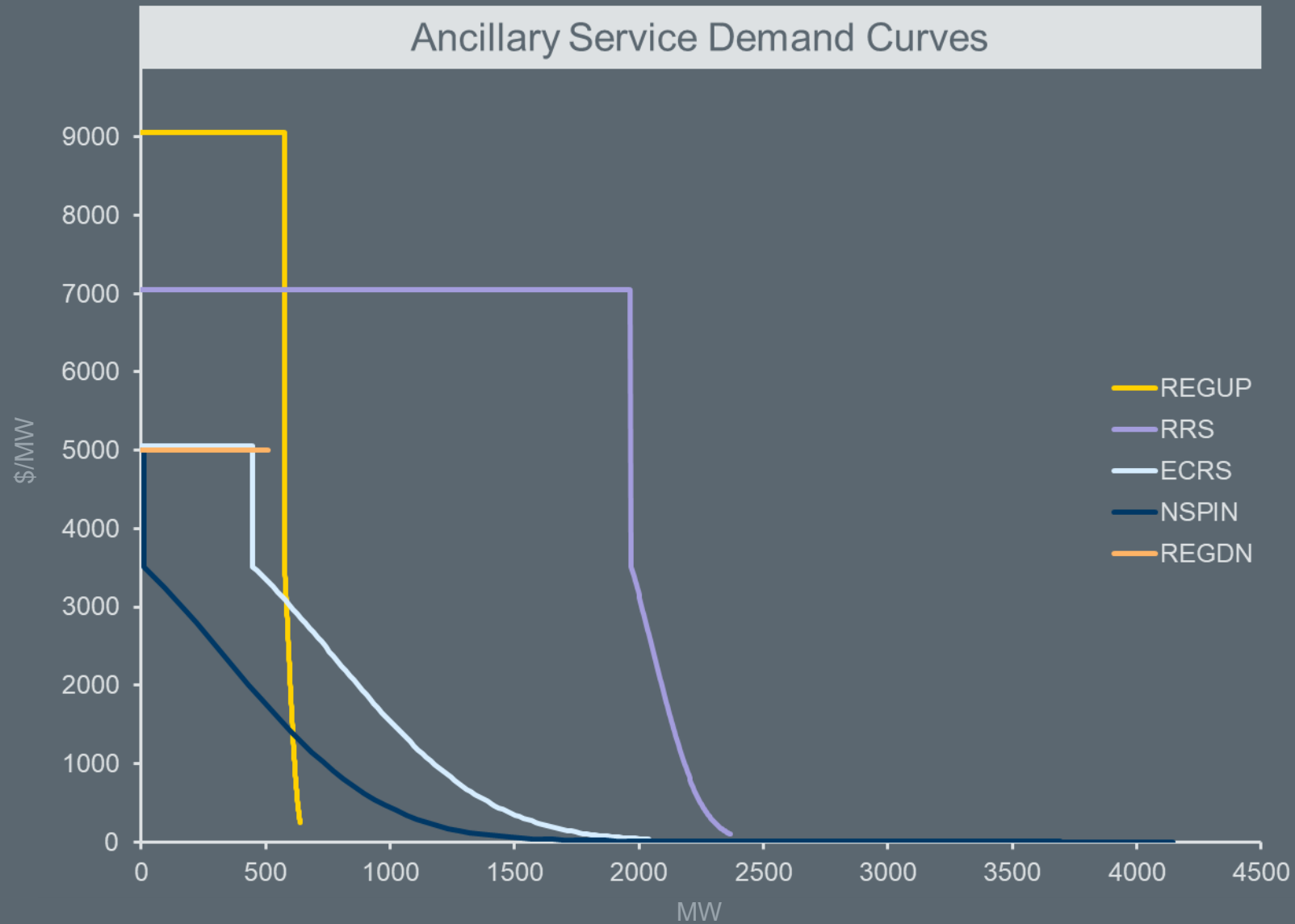



Load Frequency Control

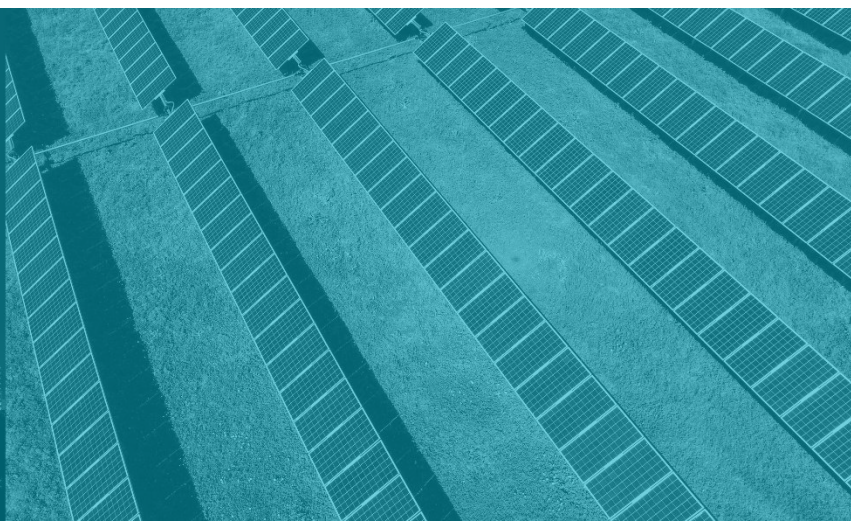

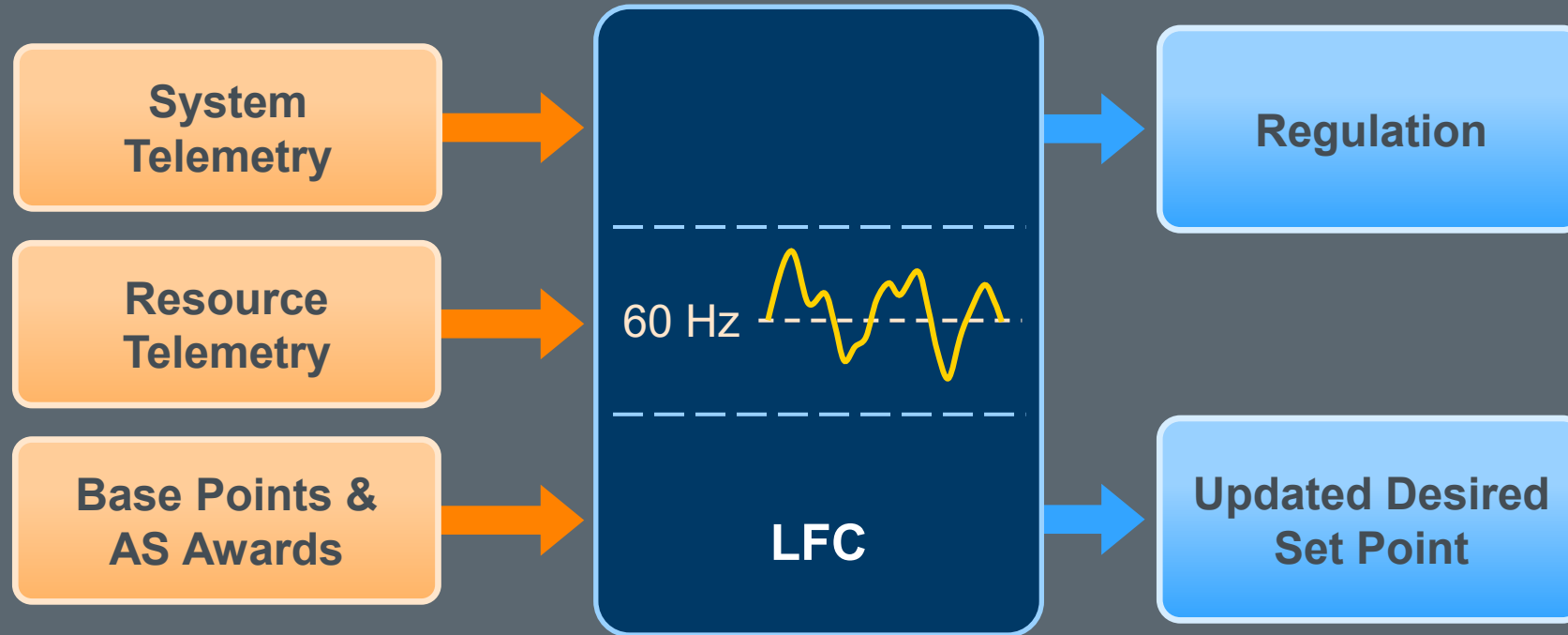

Runs every 4 seconds!



Deployed by pro-rata share

- Resource-specific
- No price consideration



Instructed output level of Resource to meet:

- SCED Base Point Ramping
- Regulation deployments
- Expected FFR deployments

Responsive Reserve is frequency responsive



RRSPF – Primary Frequency Response

- Automatic Response at 59.983 Hz
- Proportional to frequency decay

RRSFF – Fast Frequency Response

- Auto-deployed at 59.85 Hz
- Responds within 15 Cycles

RRSUF – Load Resource on Under-Frequency Relay

- Auto-deployed at 59.70 Hz
- Trips within 30 cycles

Regulation Deployments and UDSP sent to QSEs





Financial Impacts

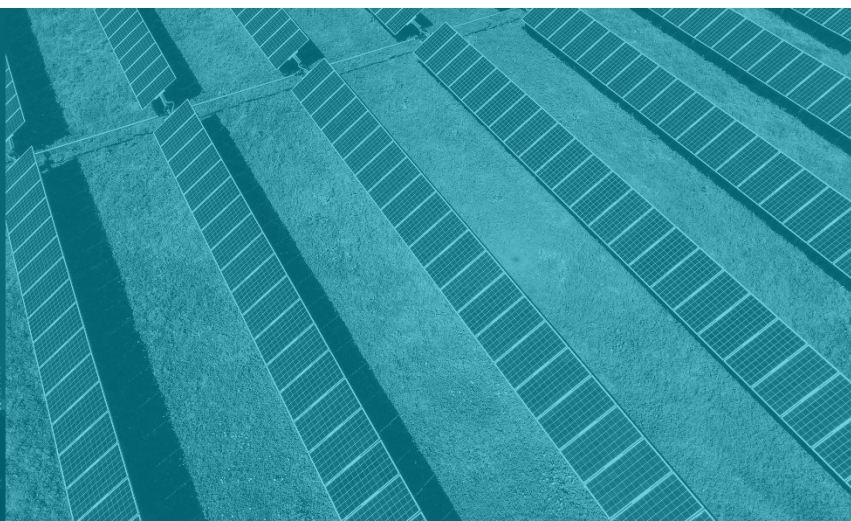

1

Real-Time Pricing

2

Energy and Ancillary Service Settlement

3

Set Point Deviation

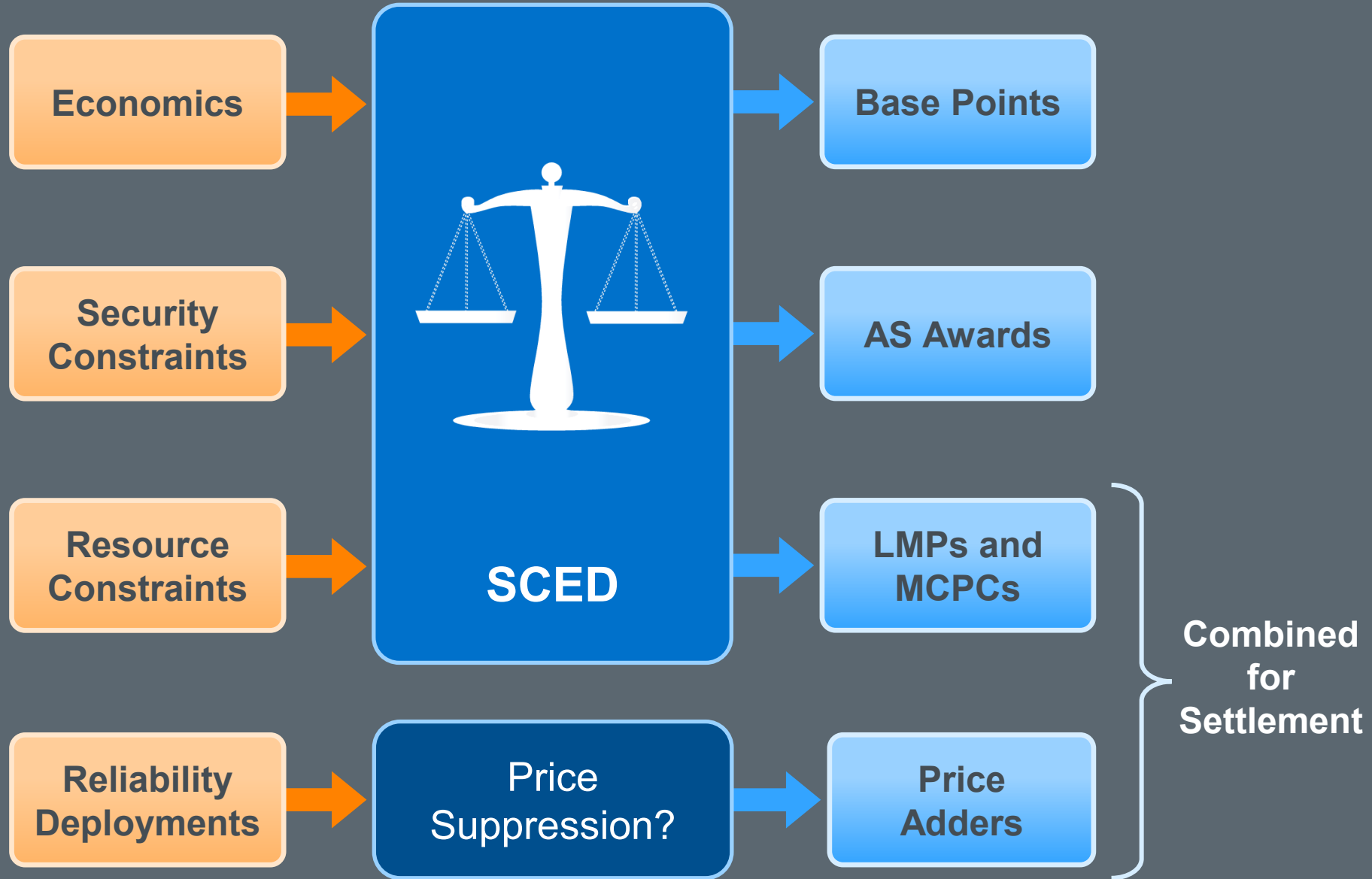

RTRDPA – Real-Time
Reliability
Deployment
Price Adder

RTRDPA[AS] – Real-Time
Reliability
Deployment
Price Adder
per AS Product

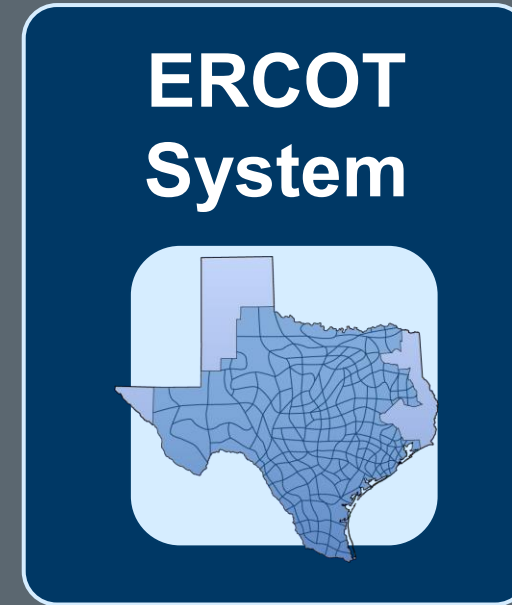

... for each SCED interval

$$\text{Real-Time Settlement Point Prices (RTSPPs)} \\ = \text{Ave (RTLMPs)} + \text{Ave (RTRDPAs)}$$

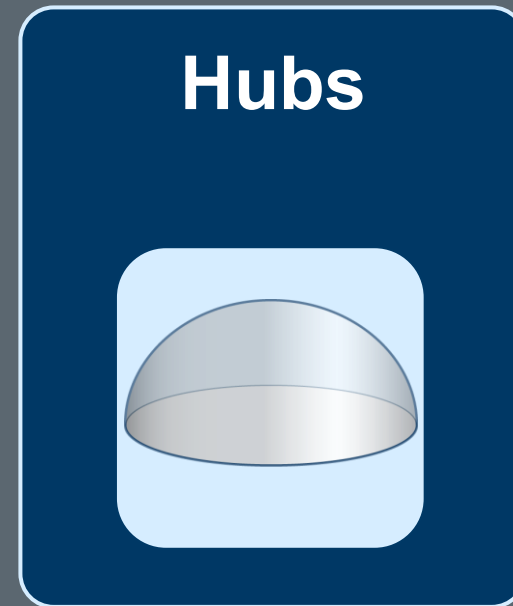
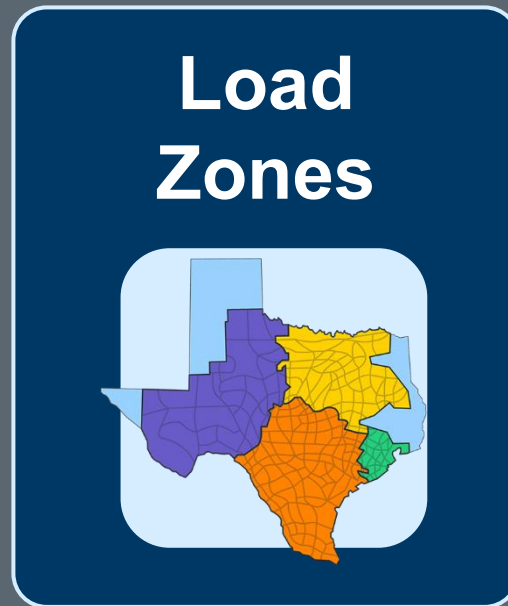
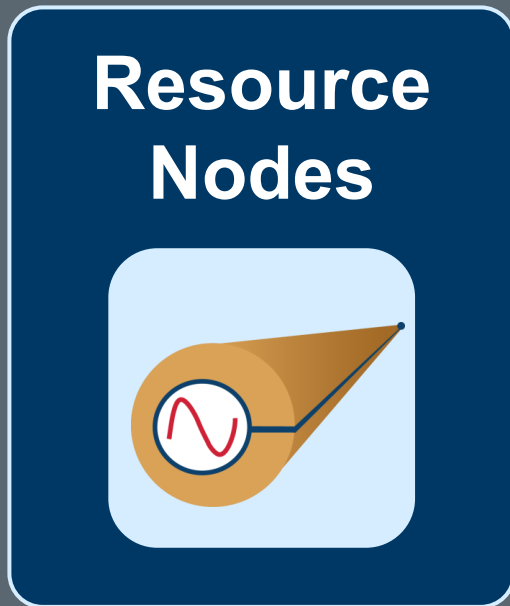

... for each 15-minute interval

Real-Time Market Clearing Prices for Capacity (MCPCs)*

$RTMCPCRU = Ave (RTMCPCRUS) + Ave (RTRDPARUS) - \text{Regulation-Up}$

$RTMCPCRD$ – Regulation-Down

$RTMCPCRR$ – Responsive Reserve

$RTMCPC \underline{E} CR$ – Contingency Reserve

$RTMCPC \underline{N} S$ – Non-Spin Reserve

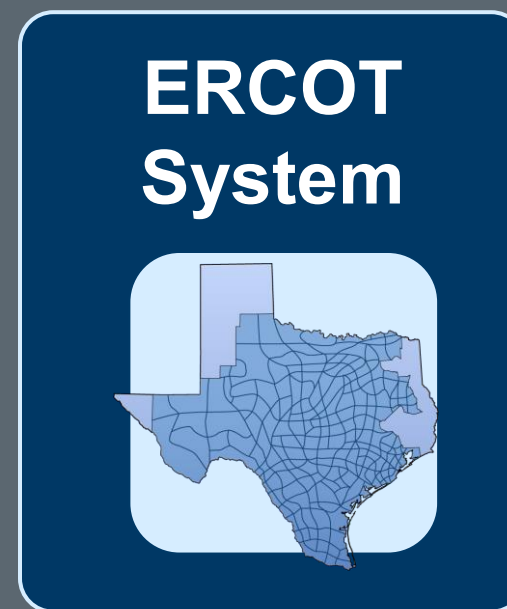

* *RT MCPCs capped at VOLL*

... for each 15-minute interval

1

Real-Time Pricing

2

Energy and Ancillary Service Settlement

3

Set Point Deviation

Real-Time Energy Imbalance

$$= (-1) \left[\begin{array}{c} \text{Metered Generation} \\ + \\ \text{DAM Energy Purchases} \\ + \\ \text{Trade Energy Purchases} \end{array} \right] - \left[\begin{array}{c} \text{DAM Energy Sales} \\ + \\ \text{Trade Energy Sales} \\ + \\ \text{Metered Load} \end{array} \right] * \text{RTSPP}$$

Supplies
Obligations

Each Settlement Point settled separately



QSE has transactions for their Resource



Generation Resource

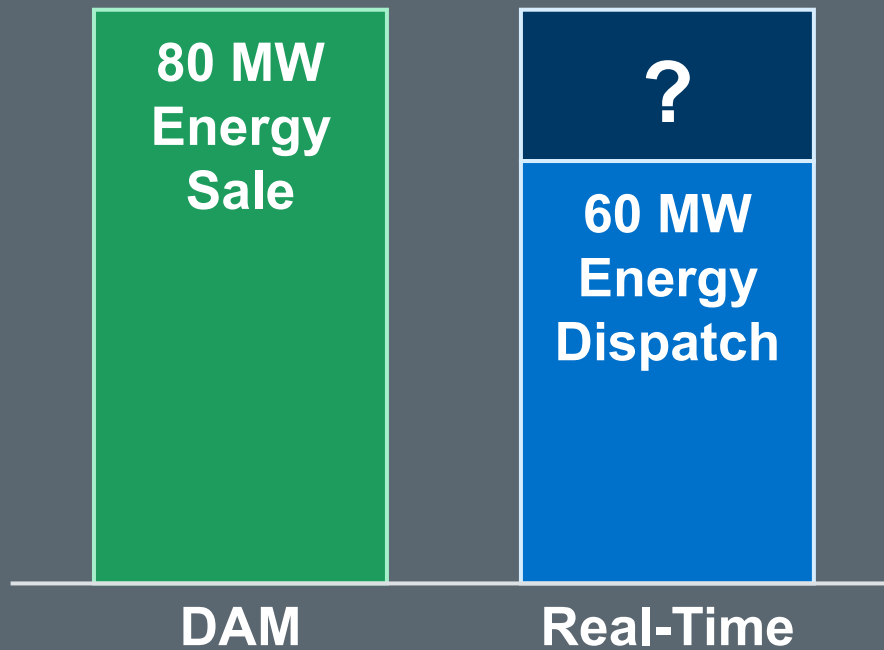



QSE has transactions for their Resource



Generation Resource

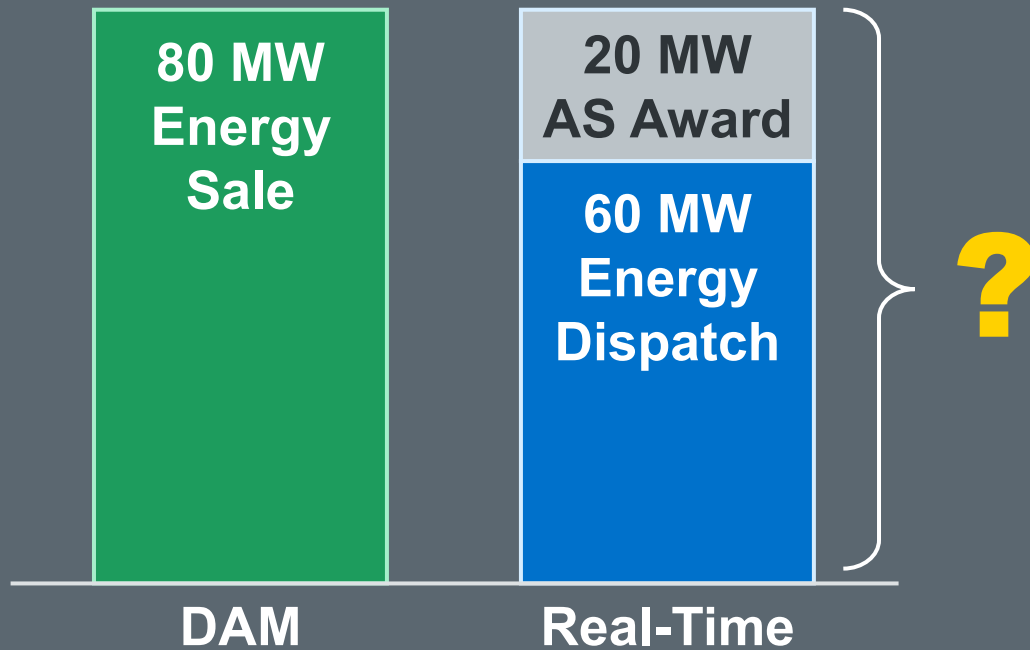



QSE has transactions for their Resource



Generation Resource

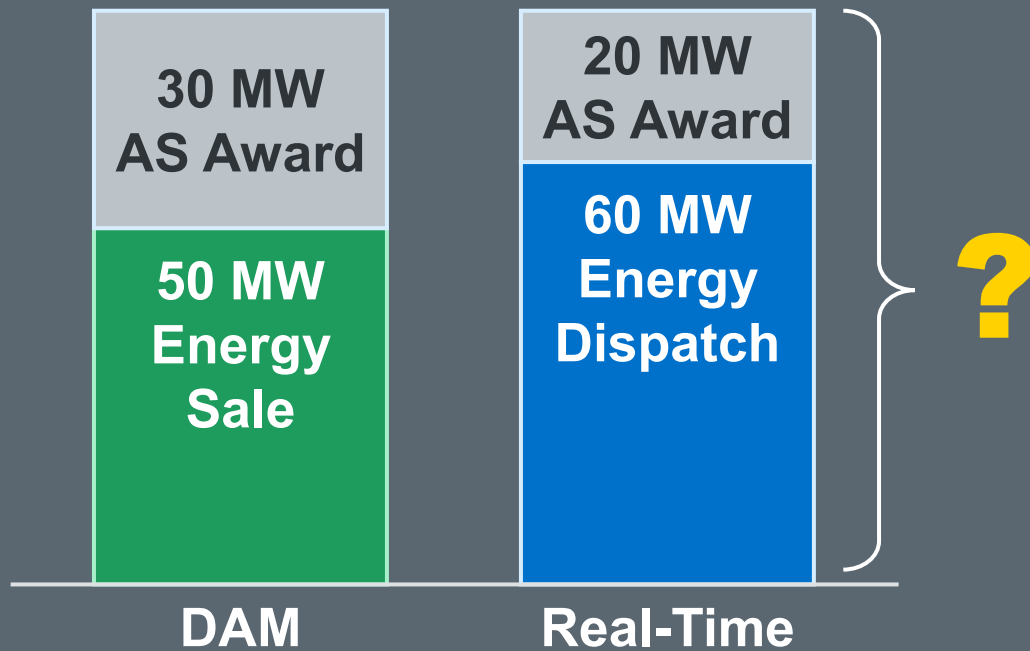



QSE has transactions for their Load



Houston Load Zone

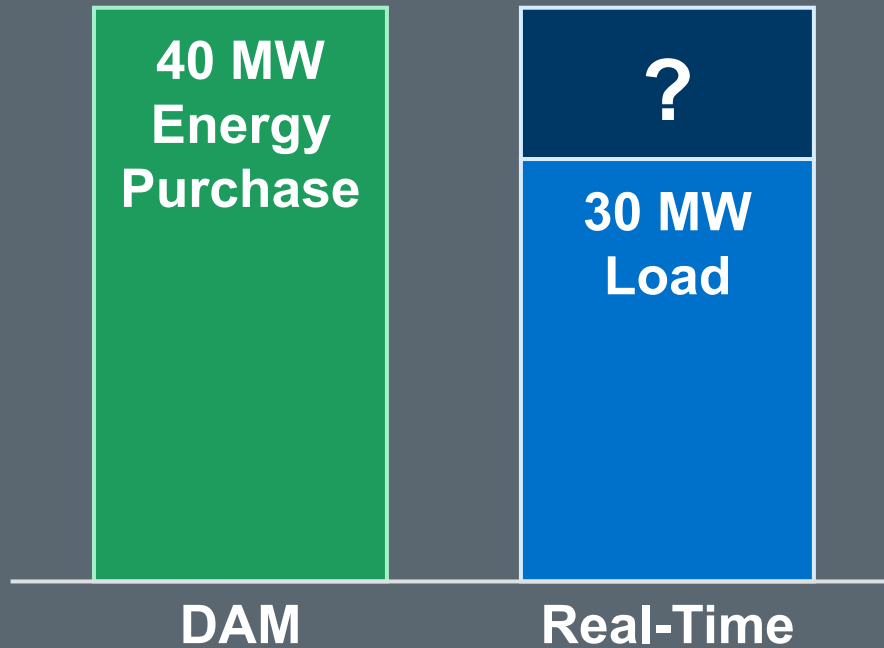



QSE has transactions for their Load



Houston Hub

Houston Load Zone

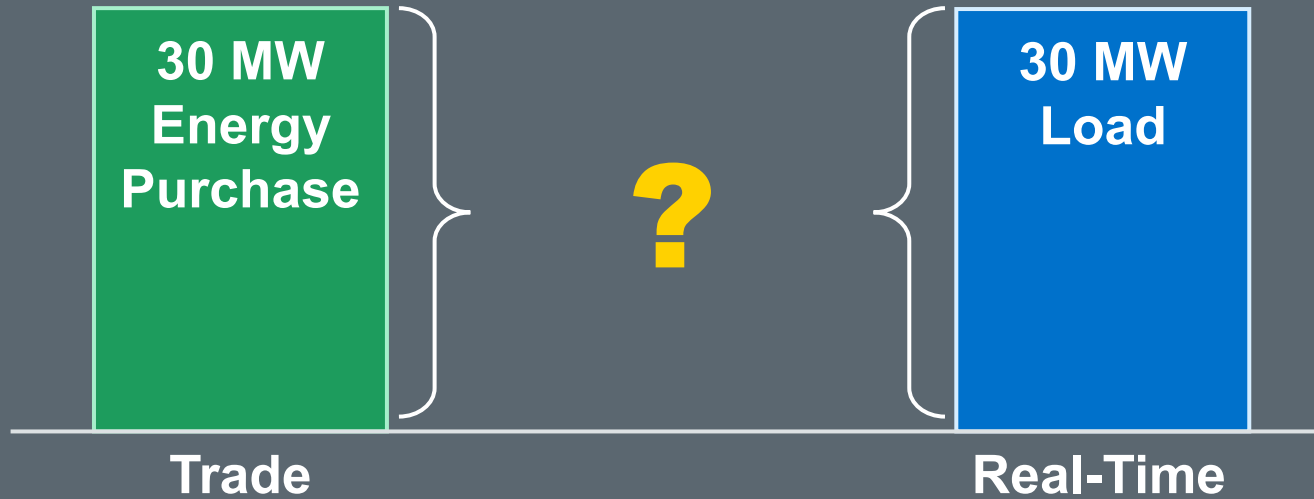

1

Real-Time Pricing

2

Energy and Ancillary Service Settlement

3

Set Point Deviation

Resource shall follow Updated Desired Set Point



QSE may be charged if Resource outside tolerance

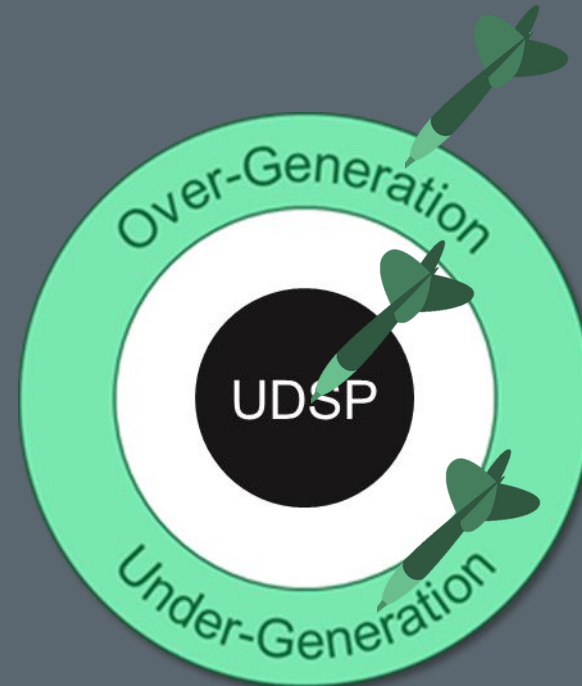

Protocol Tolerances

- Greater of $\pm 5\%$ or $\pm 5\text{MW}$
- 5% for IRRs that over-generate with no Ancillary Service awards
- Greater of $\pm 3\%$ or $\pm 3\text{MW}$ for ESRs

Waived if two conditions are met

1. Frequency deviation greater than 0.05Hz
2. Resource's deviation helps correct frequency

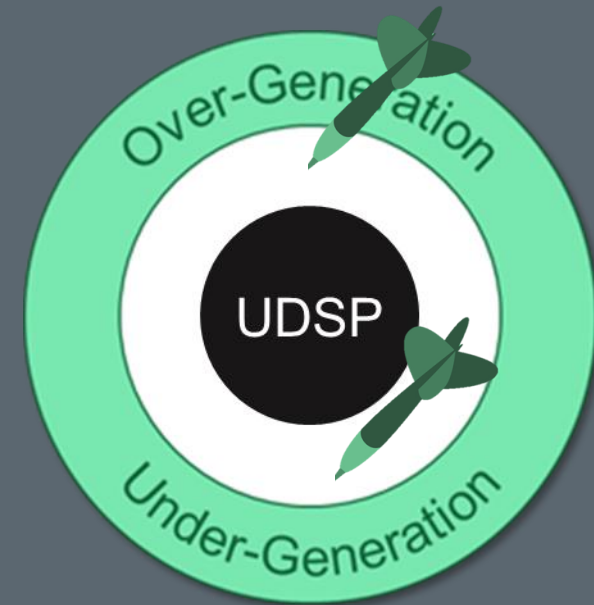



Does the QSE incur a Set Point Deviation Charge?

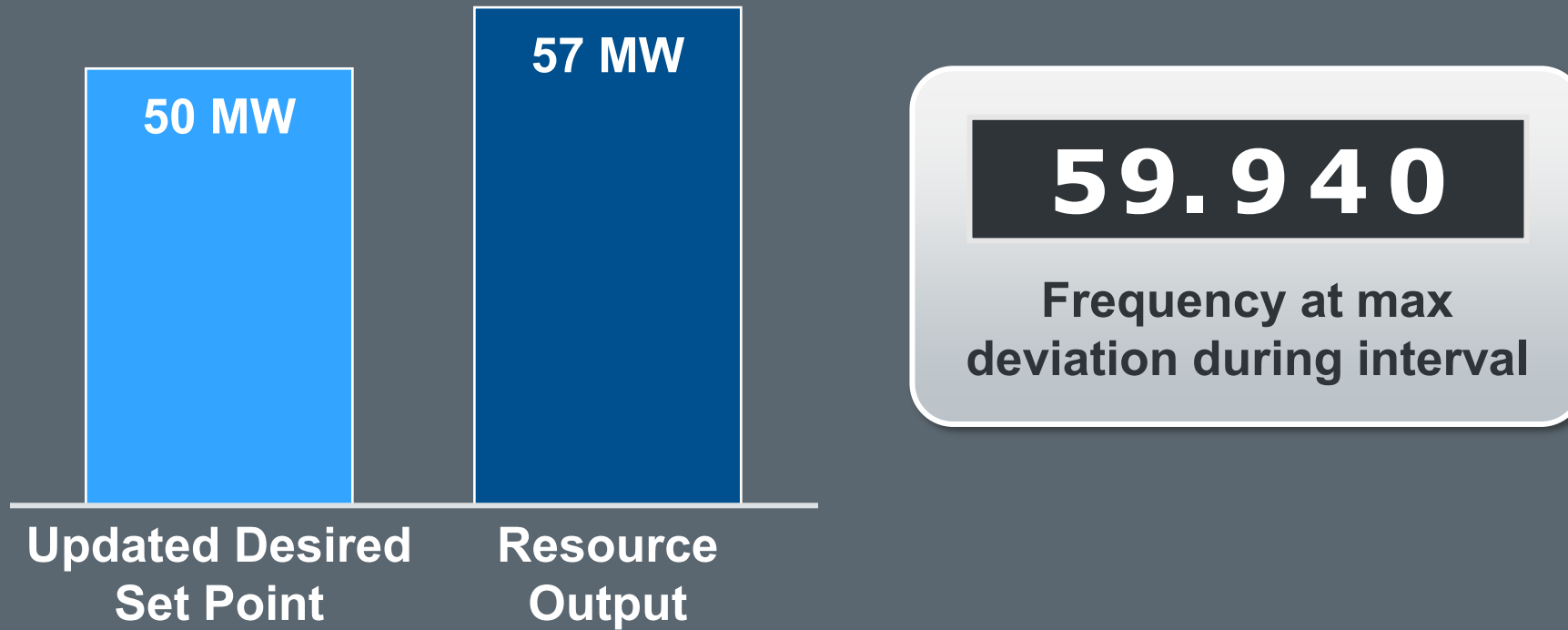



Does the QSE incur a Set Point Deviation Charge?

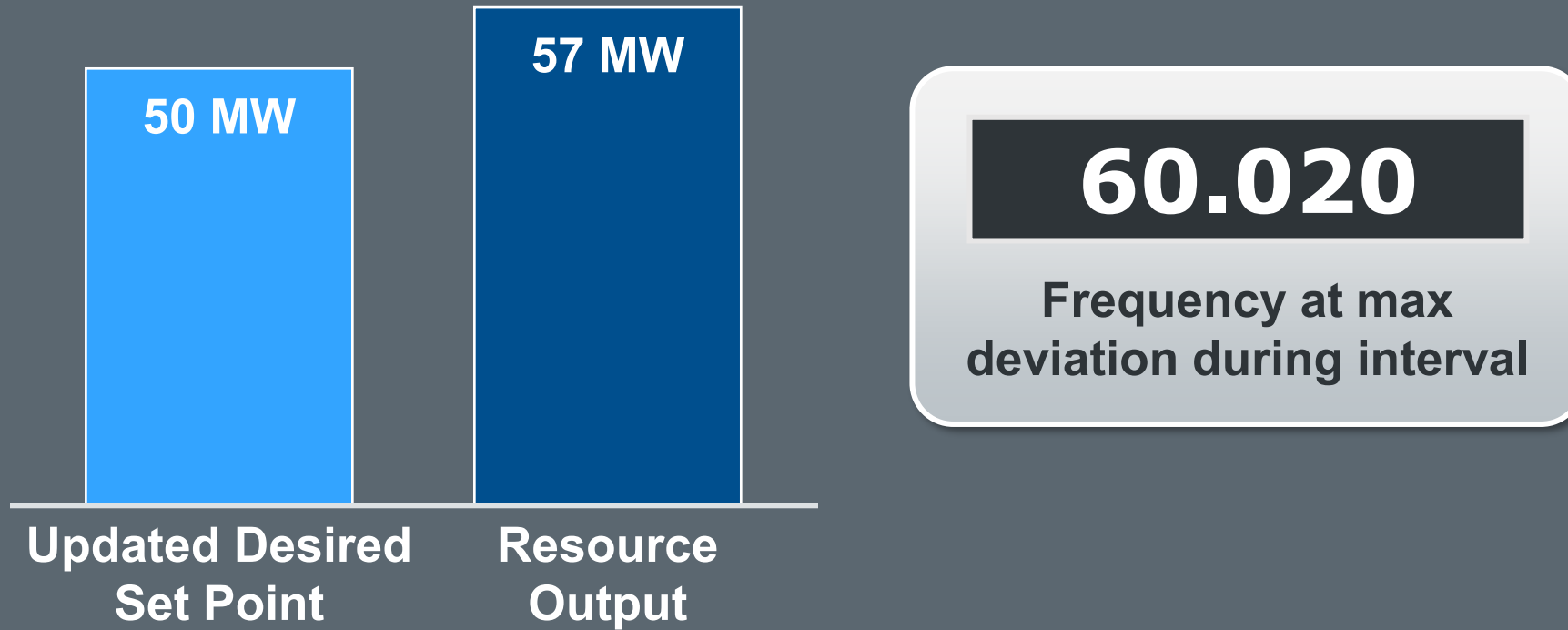



Does the QSE incur a Set Point Deviation Charge?

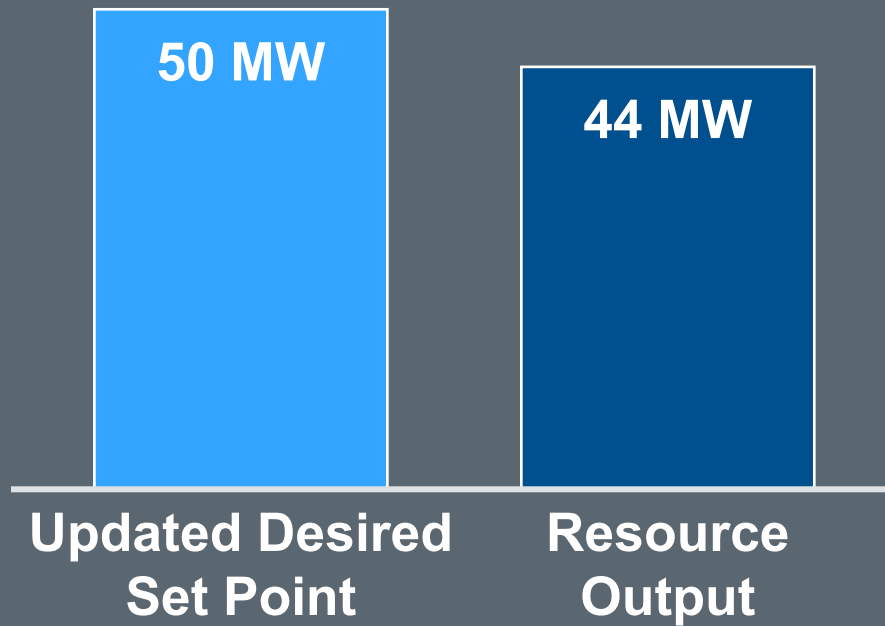

A digital display with a black background and white text showing the value '60.020'. Below the display, the text reads 'Frequency at max deviation during interval'.

60.020
Frequency at max deviation during interval



Set Point
Deviation
Charges

Set Point
Deviation
Payments

Course Wrap-Up

Format	Title
WBT	Wholesale Markets Overview

Format	Title	Topic
ILT	Day-Ahead Market Operations	Inputs
		Market Clearing
		Financial Impacts
	Reliability Unit Commitment	Overview
		Process
		Financial Impacts
	Real-Time Market Operations	Security Constrained Economic Dispatch
		Load Frequency Control
		Financial Impacts

ERCOT Training Information

<http://www.ercot.com/services/training/>

Course Recommendations

<https://www.ercot.com/services/training/recommendations>

Market Education Contact

Training@ercot.com

ERCOT Client Services Contact

Clientservices@ercot.com

ERCOT Mailing Lists

<http://lists.ercot.com/>

Scan this QR code to take the course survey!

<https://www.surveymonkey.com/r/ERCOTILT>

