

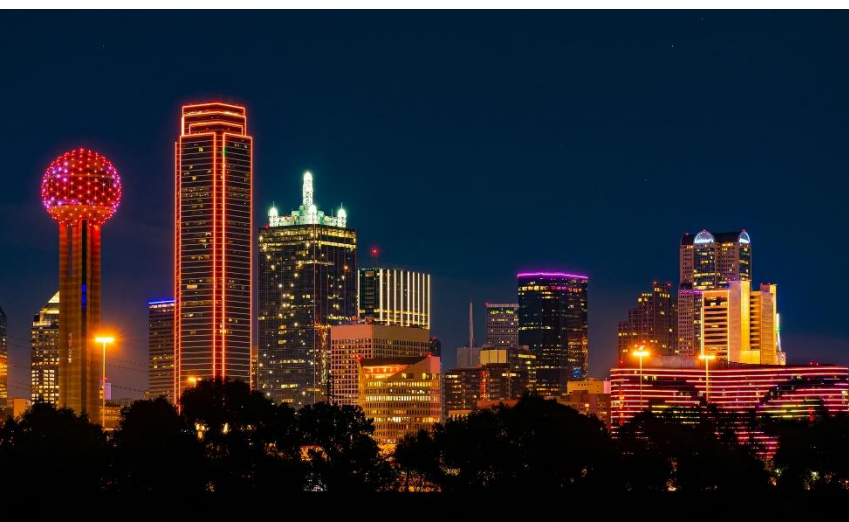

Reliability Unit Commitment



2026_04 Reliability Unit Commitment



Greetings
and
Introductions

Attendance

Questions

Presentation Materials



PROTOCOL DISCLAIMER

This presentation provides a general overview of the Texas Nodal Market and is not intended to be a substitute for the ERCOT Protocols, as amended from time to time. If any conflict exists between this presentation and the ERCOT Protocols, the ERCOT Protocols shall control in all respects.

For more information, please visit:

<http://www.ercot.com/mktrules/nprotocols/>

Format	Title
WBT	Wholesale Markets Overview

Format	Title	Topic
ILT	Day-Ahead Market Operations	Inputs
		Market Clearing
		Financial Impacts
	Reliability Unit Commitment	Overview
		Process
		Financial Impacts
	Real-Time Market Operations	Security Constrained Economic Dispatch
		Load Frequency Control
		Financial Impacts



Overview

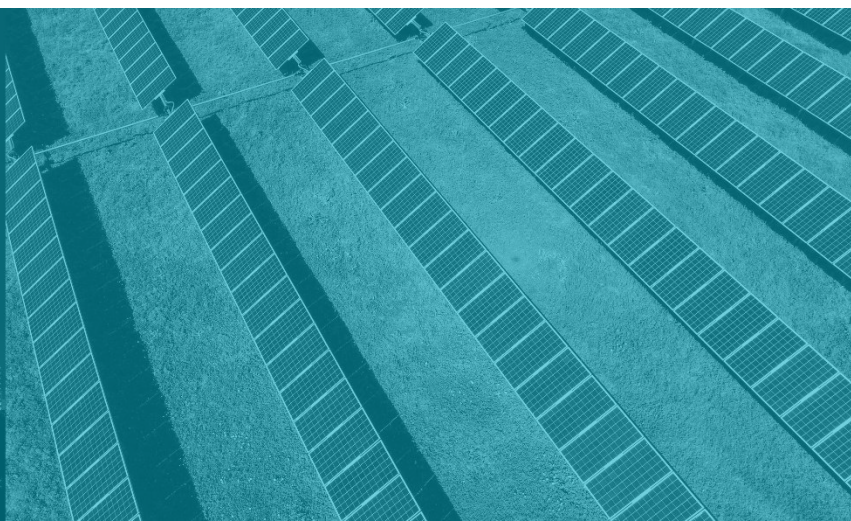



It's 11:00. For hours ending 14:00-18:00, the Load Forecast and AS Plan exceed the committed Resource Capacity by 400 MW.



1. What options does ERCOT have?
2. How do the ERCOT operators choose?

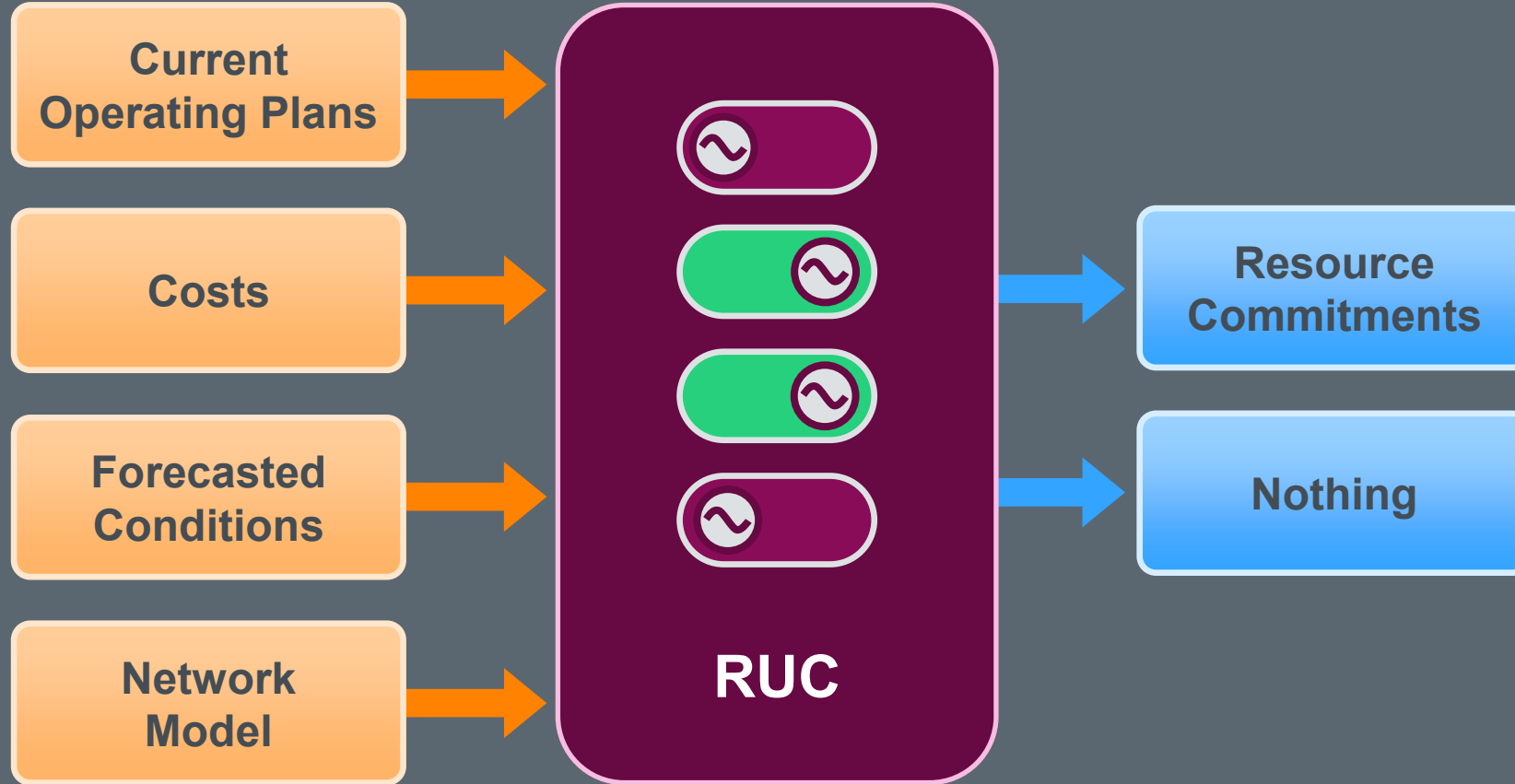

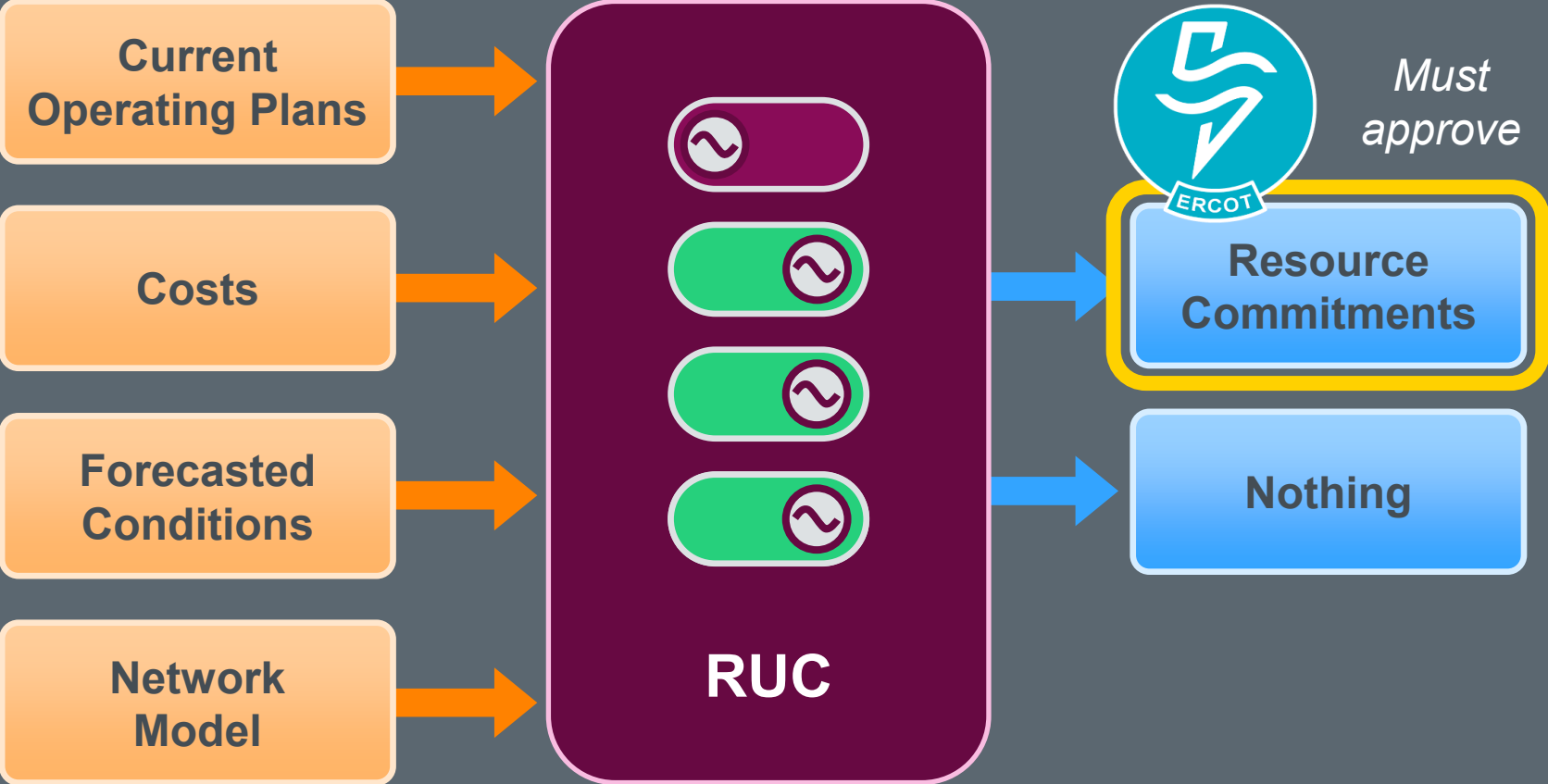

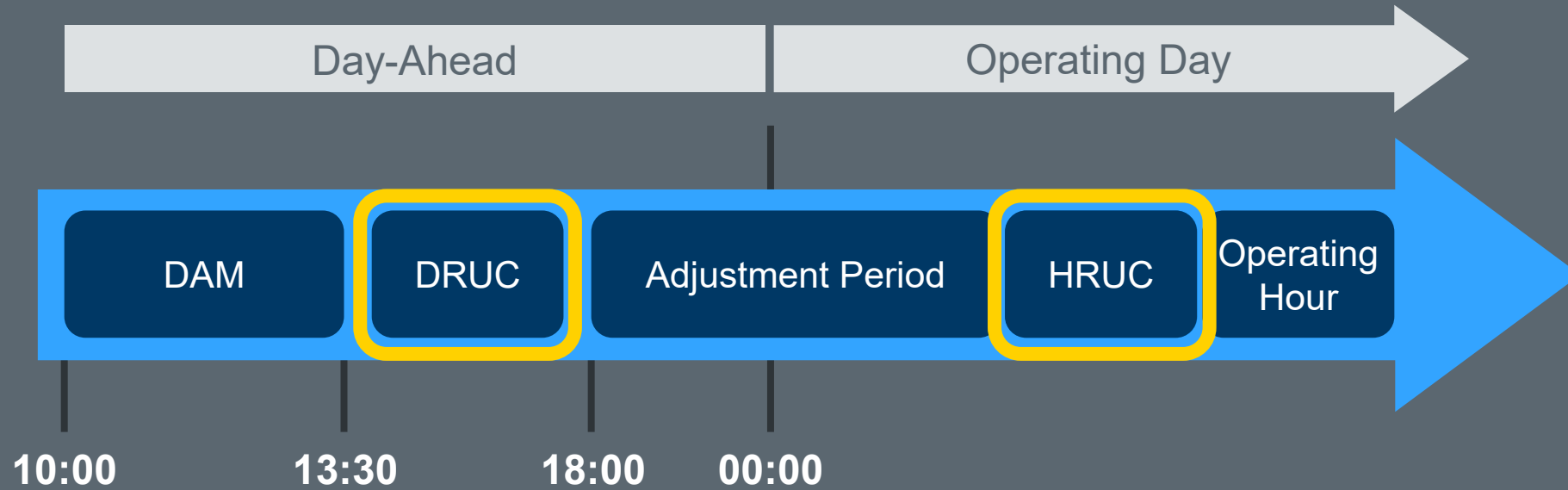

DRUC = Day-Ahead Reliability Unit Commitment

HRUC = Hourly Reliability Unit Commitment



Process

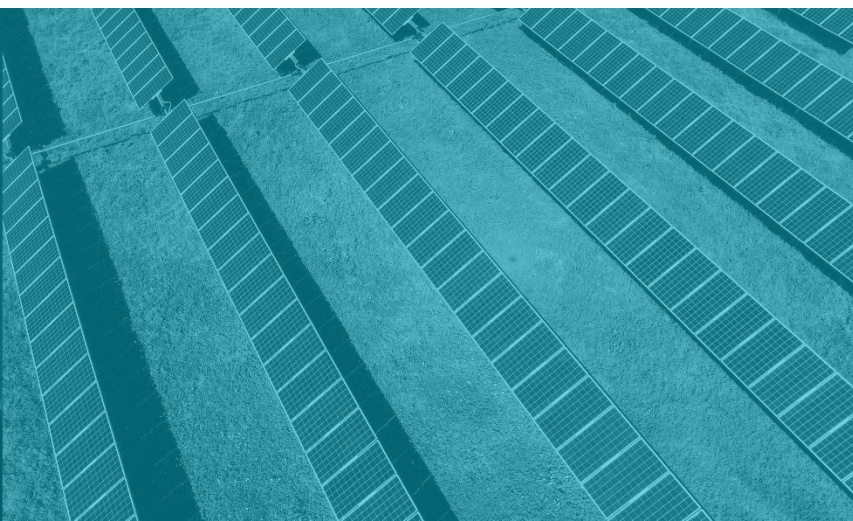

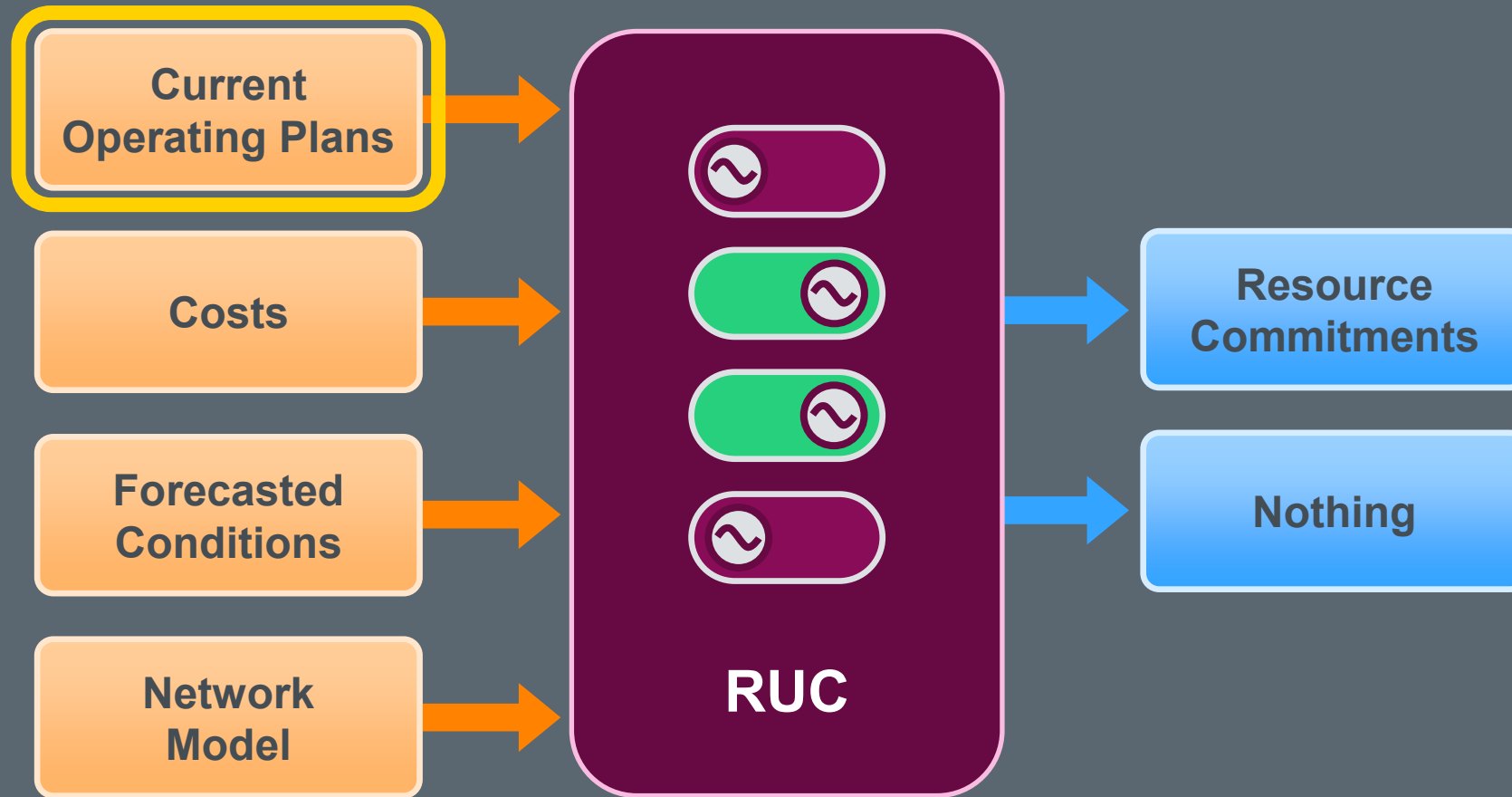

Provides critical information to RUC

Current Operating Plan											
Resource Name	Resource Status	Resource Limits		ESR SOC Limits			Ancillary Service Capabilities				
		HSL	LSL	Min	Max	Hour Beginning	Reg-Up	Reg-Dn	Responsive	ECRS	NSRS
GEN1	ON	600	120	-	-	-	20	20	40	40	120
GEN2	OUT	100	25	-	-	-	0	0	0	0	0
ESR3	ON	40	-40	0	40	40	0	0	40	40	10
GEN3	OFF	450	100	-	-	-	0	0	0	0	0

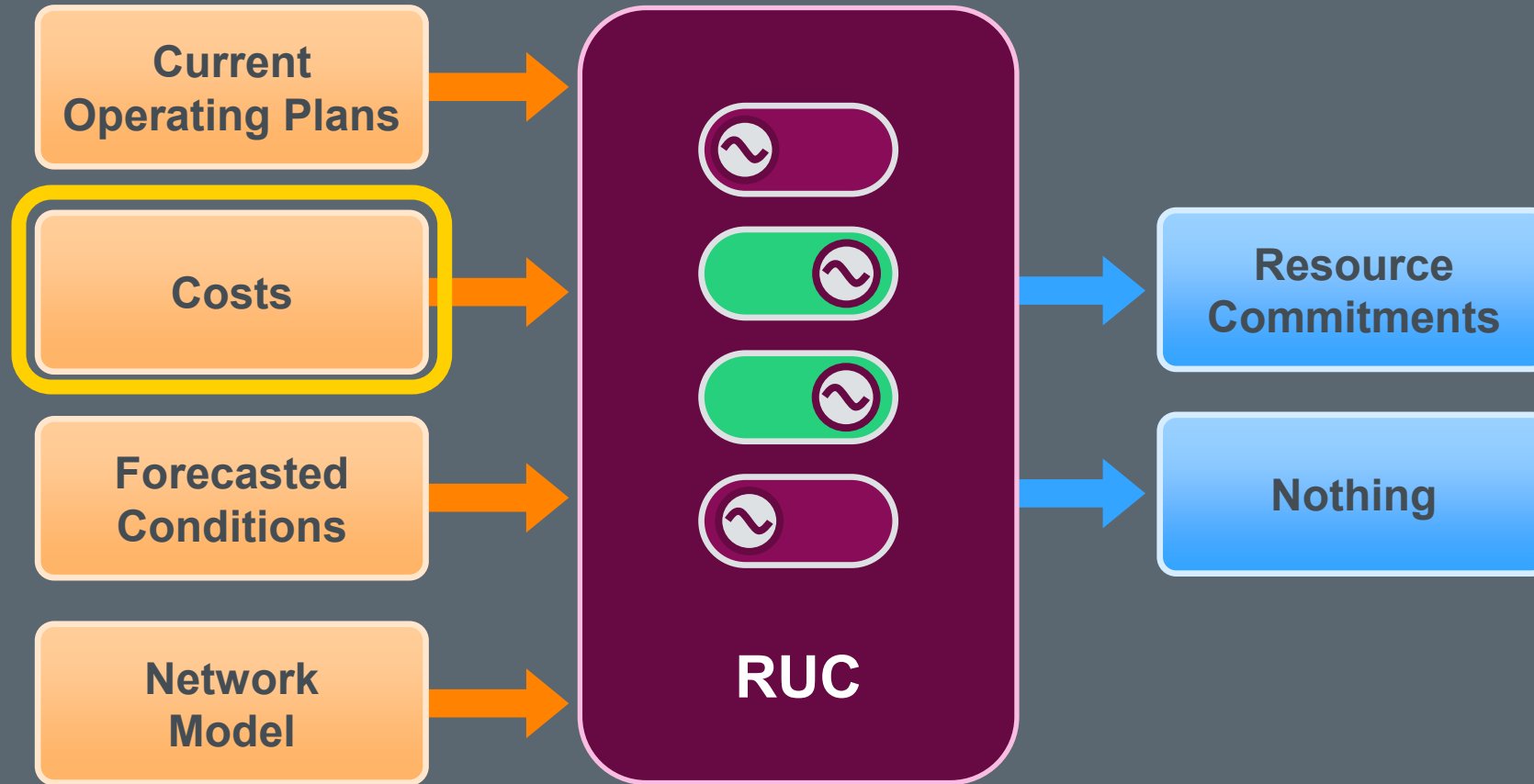

Based on Three Part Supply Offers

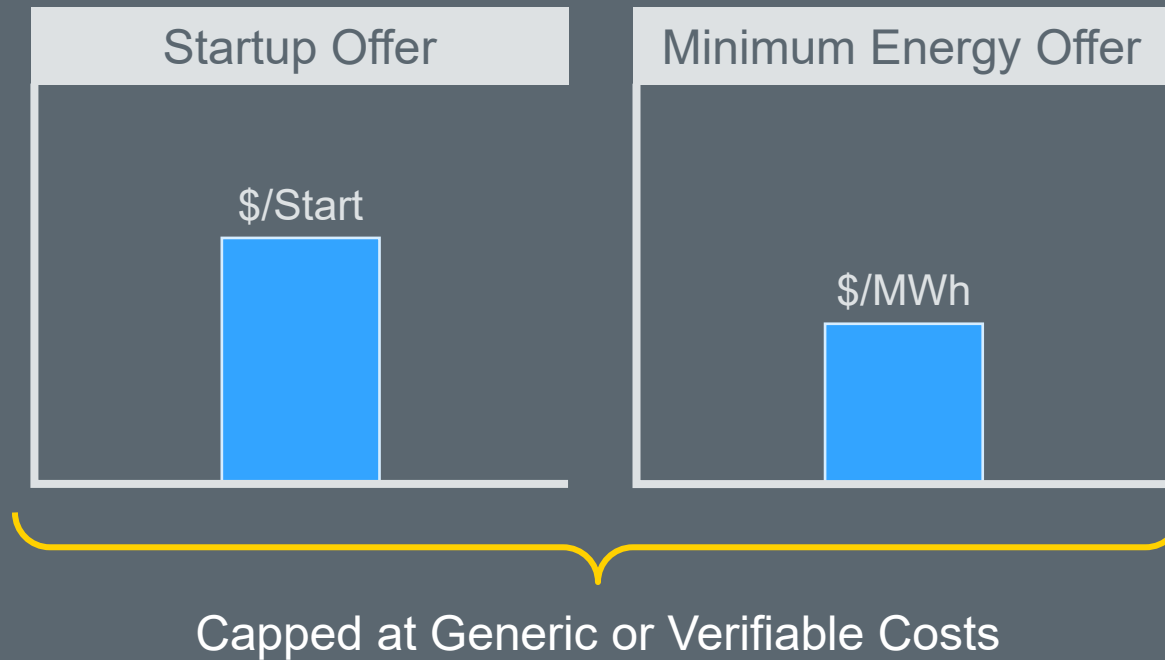
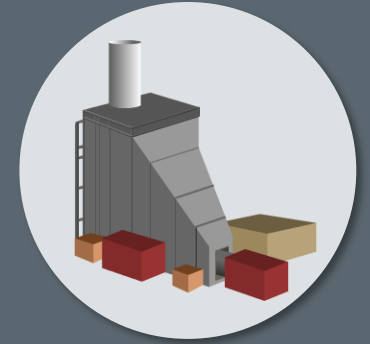

Startup Cost Considered?

- No QSE Commitments
- RUC initially commits

RUC will consider
Startup Costs

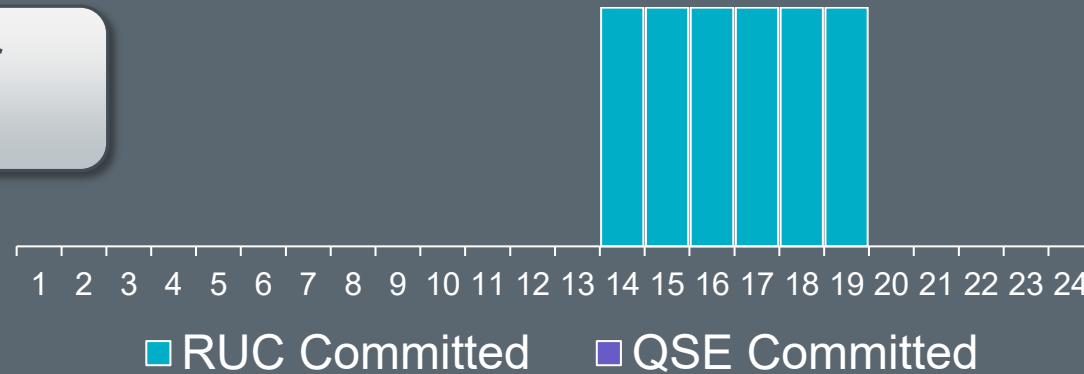

Startup Cost Considered?

- QSE initially commits
- RUC extends commitment

RUC will not consider
Startup Costs

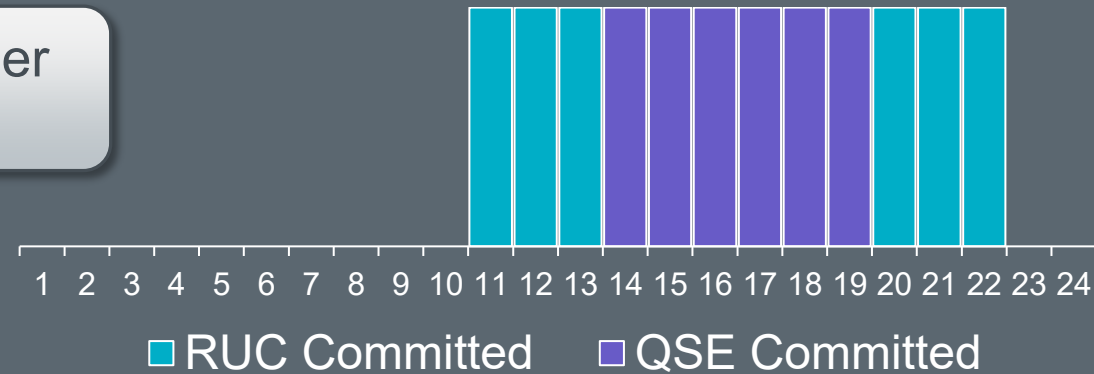

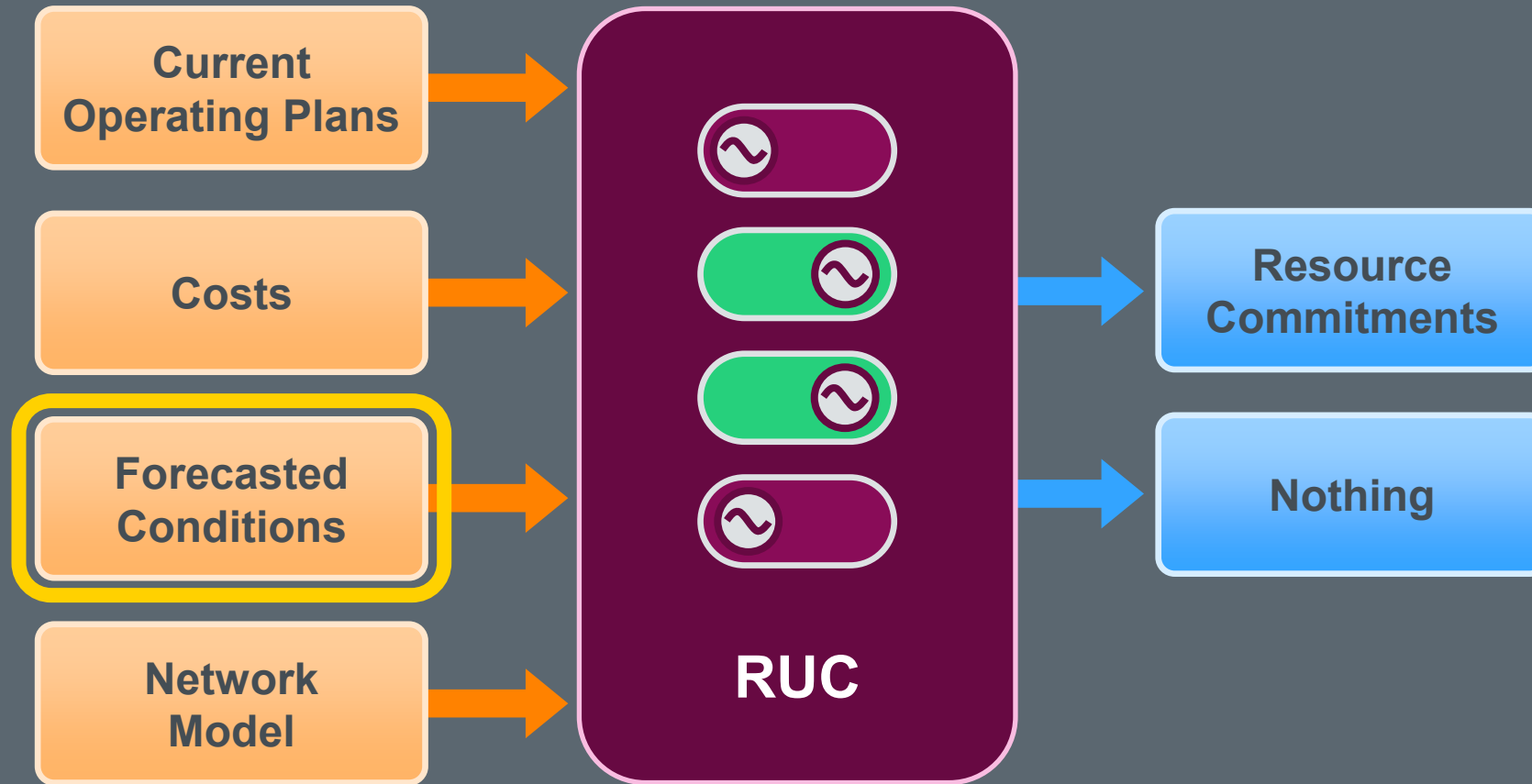

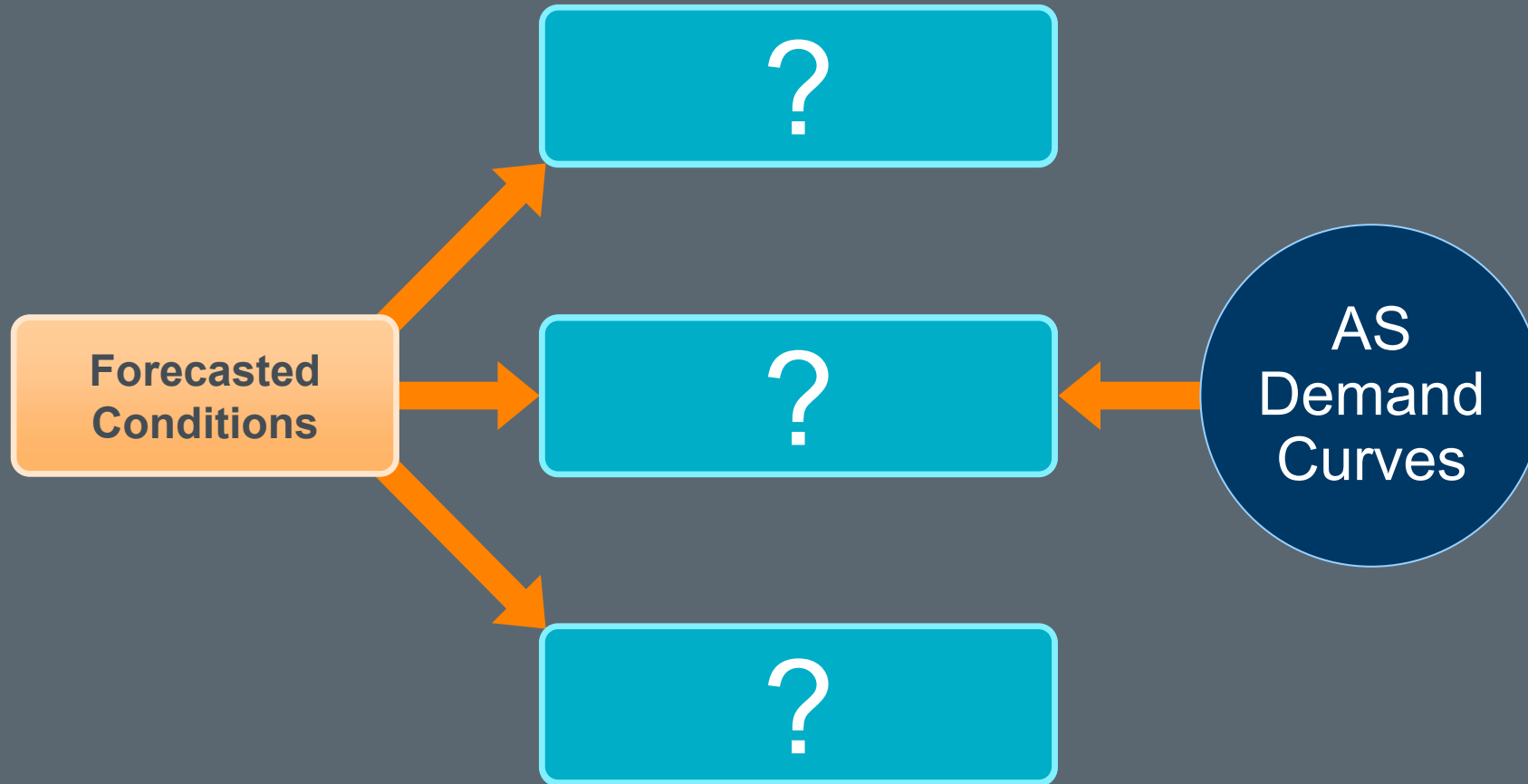

Uses expected network topology for each hour

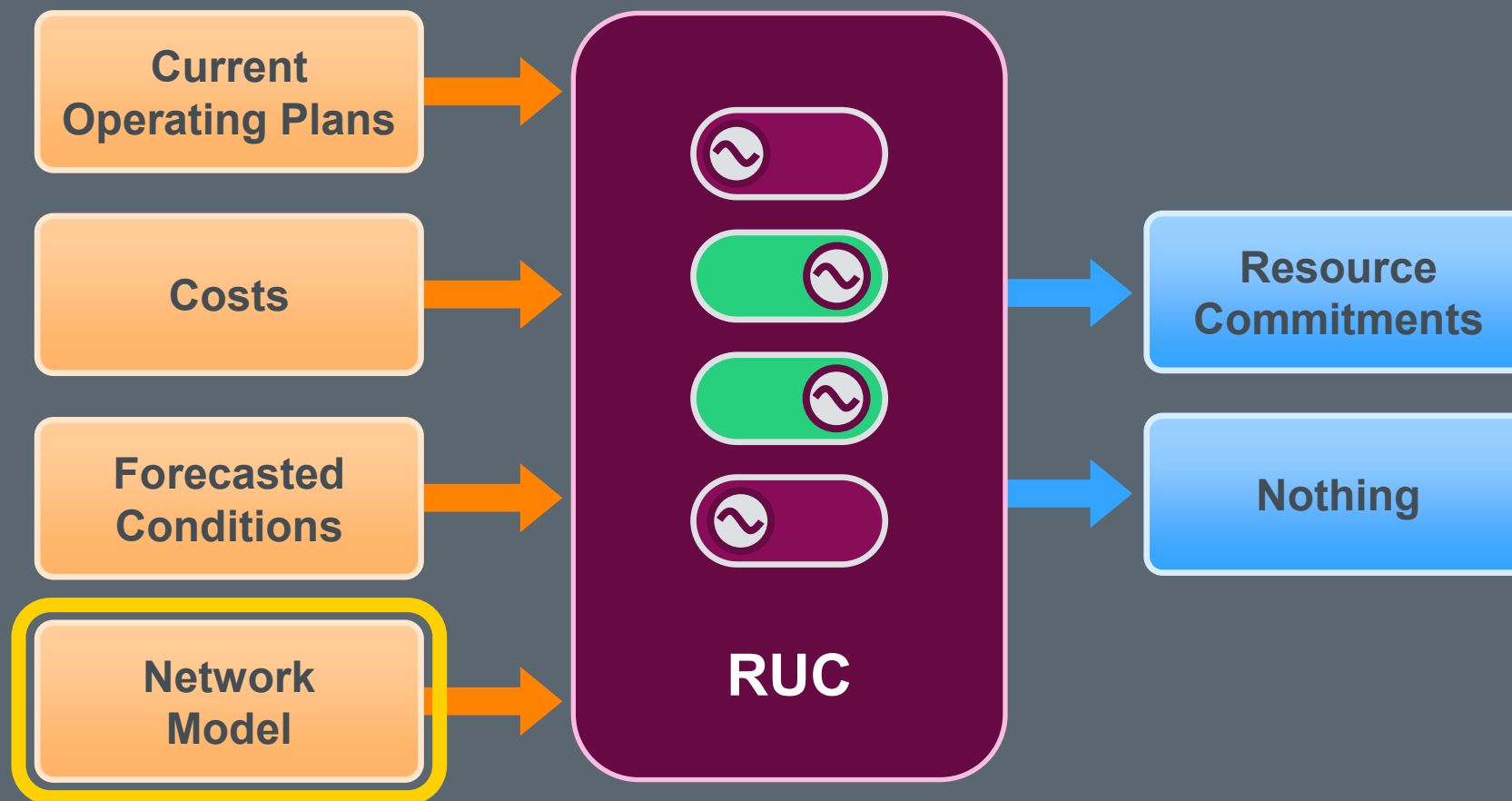

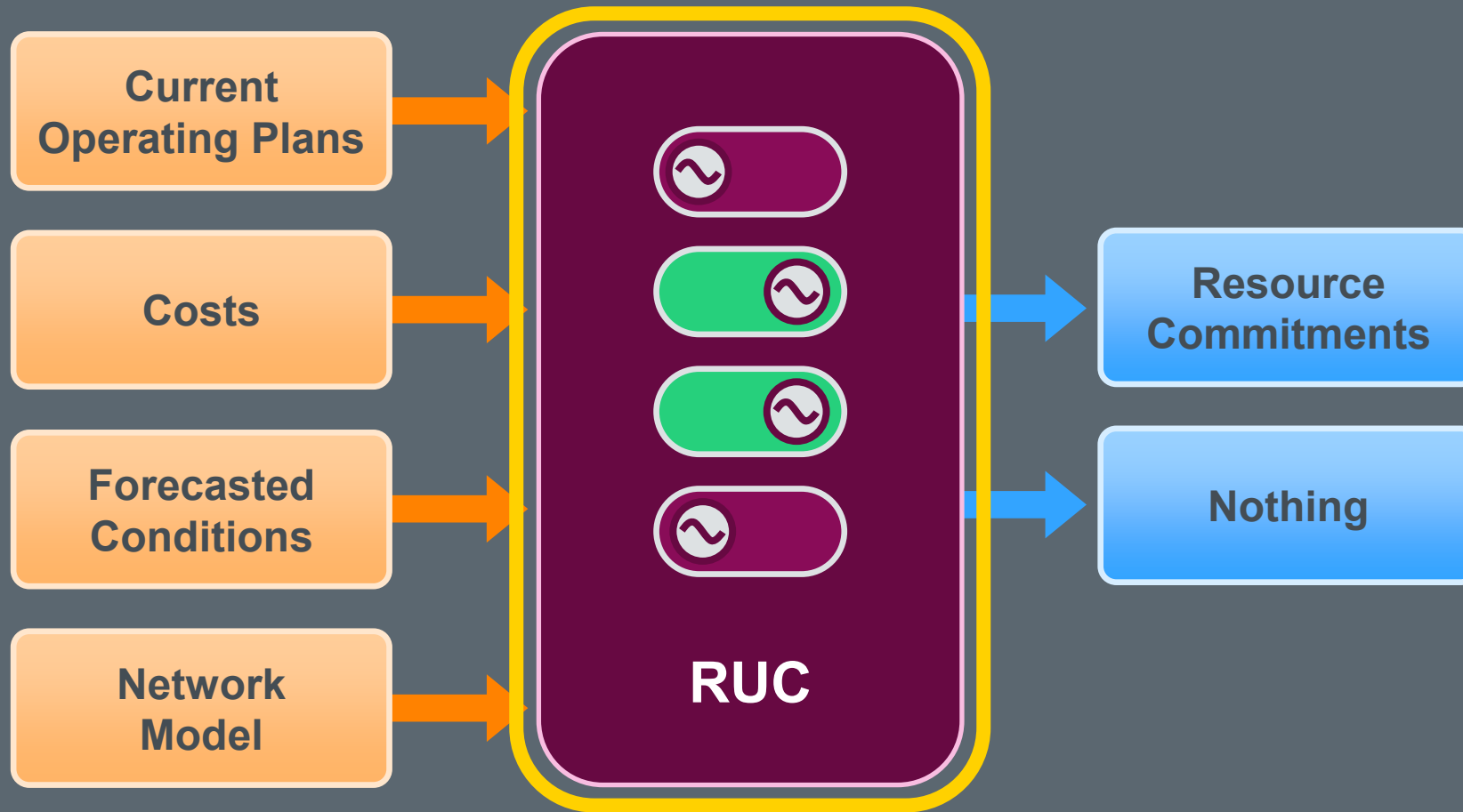

Begins with Initial Unit Commitment for each hour

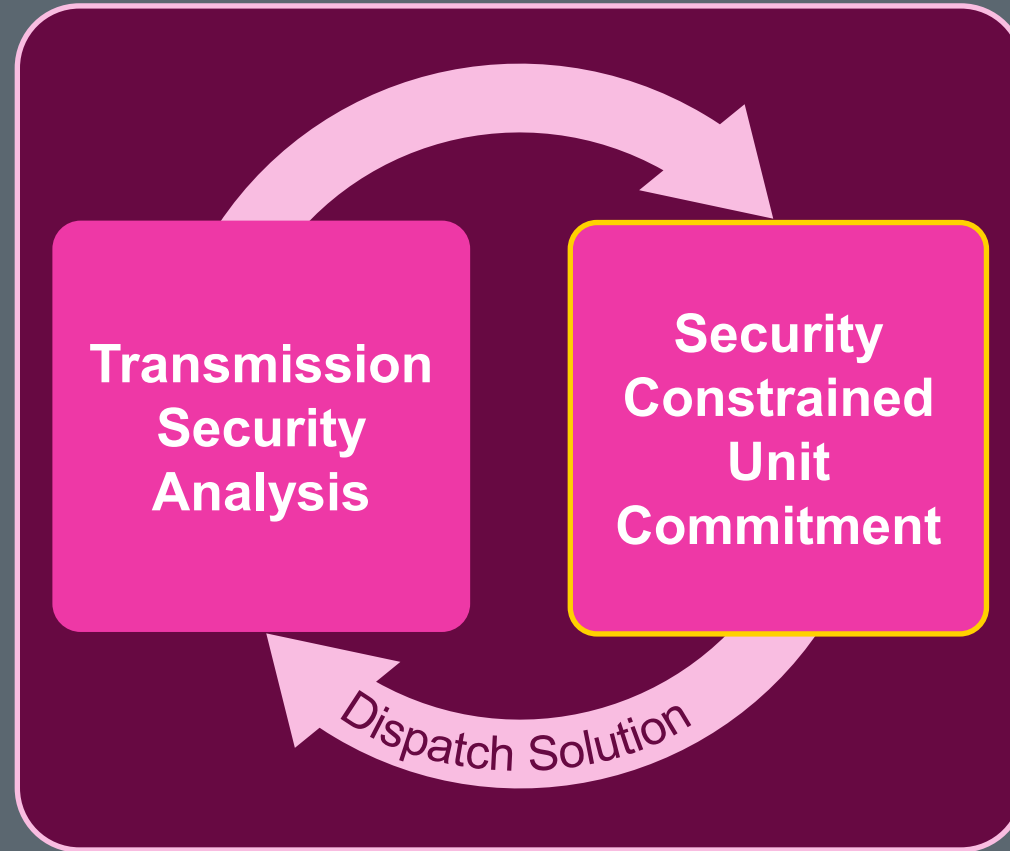

To project possible dispatch solutions

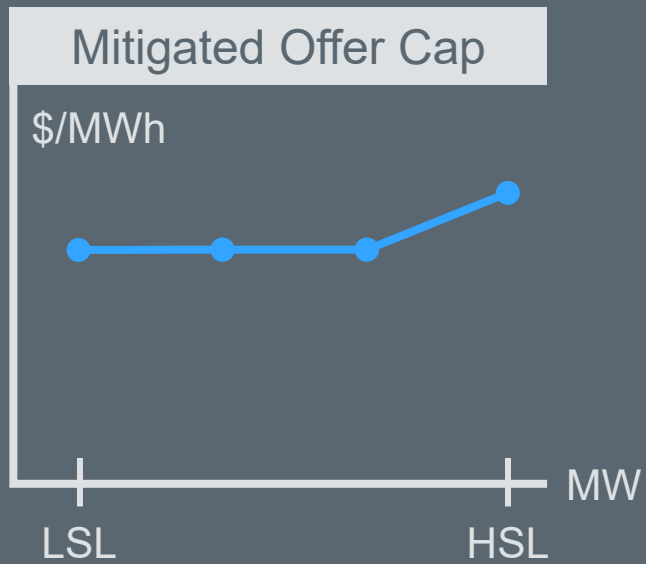
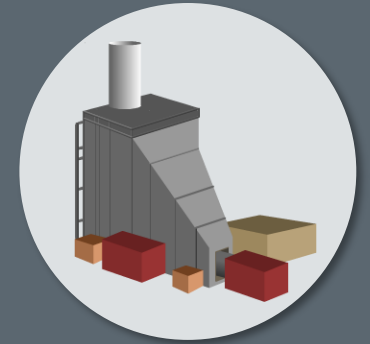

0.10%

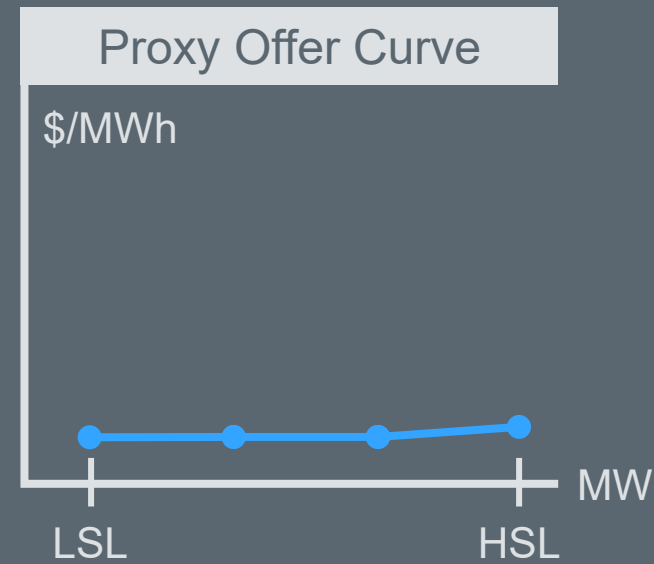

To project possible Ancillary Awards

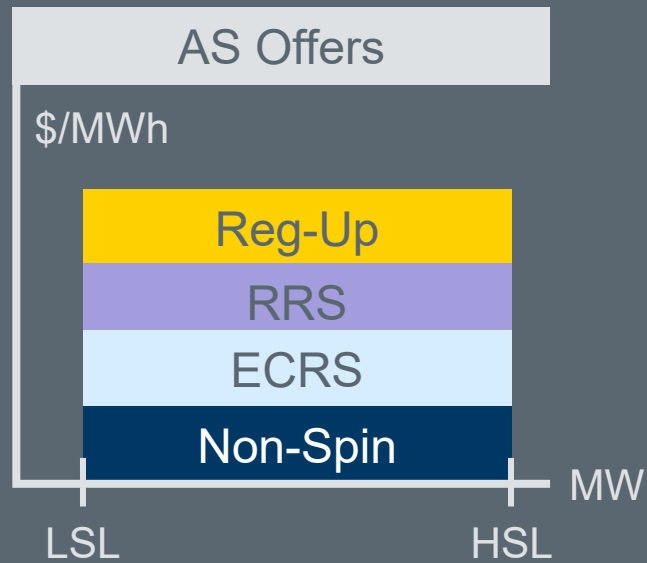
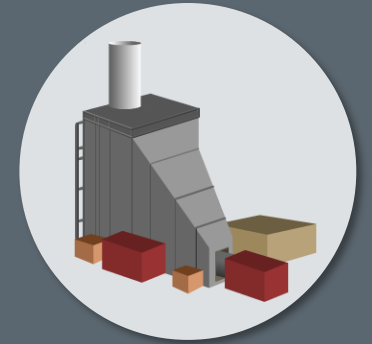

0.10%

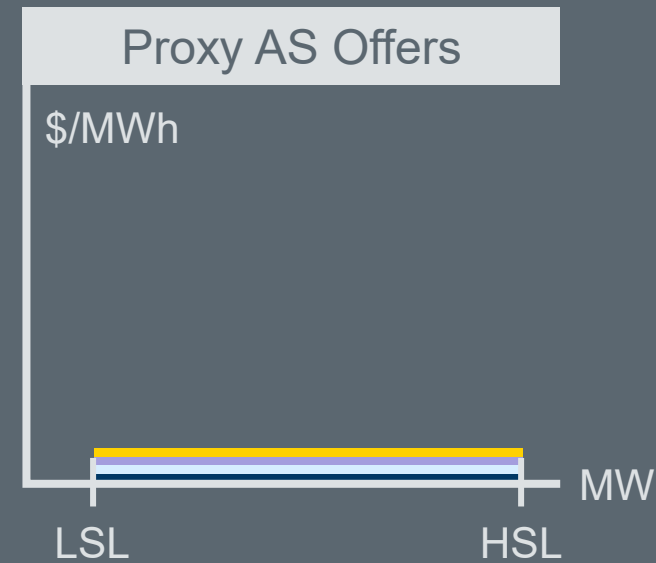



Current Operating Plan											
Hour	Resource Name	Resource Limits		ESR SOC Limits			Ancillary Service Capabilities				
		HSL	LSL	Min	Max	Hour Beginning	Reg-Up	Reg-Dn	Responsive	ECRS	NSRS
15	ESR3	40	-40	0	40	30	0	0	0	30	0
16	ESR3	40	-40	0	40	40	0	0	0	20	0
17	ESR3	40	-40	0	40	20	0	0	0	10	0
18	ESR3	40	-40	0	40	10	0	0	0	10	0

Projects dispatch that aligns with Hourly SOC changes

 Checks feasibility based on Deployment Factors

Is solution secure with all Ancillary Services awarded?

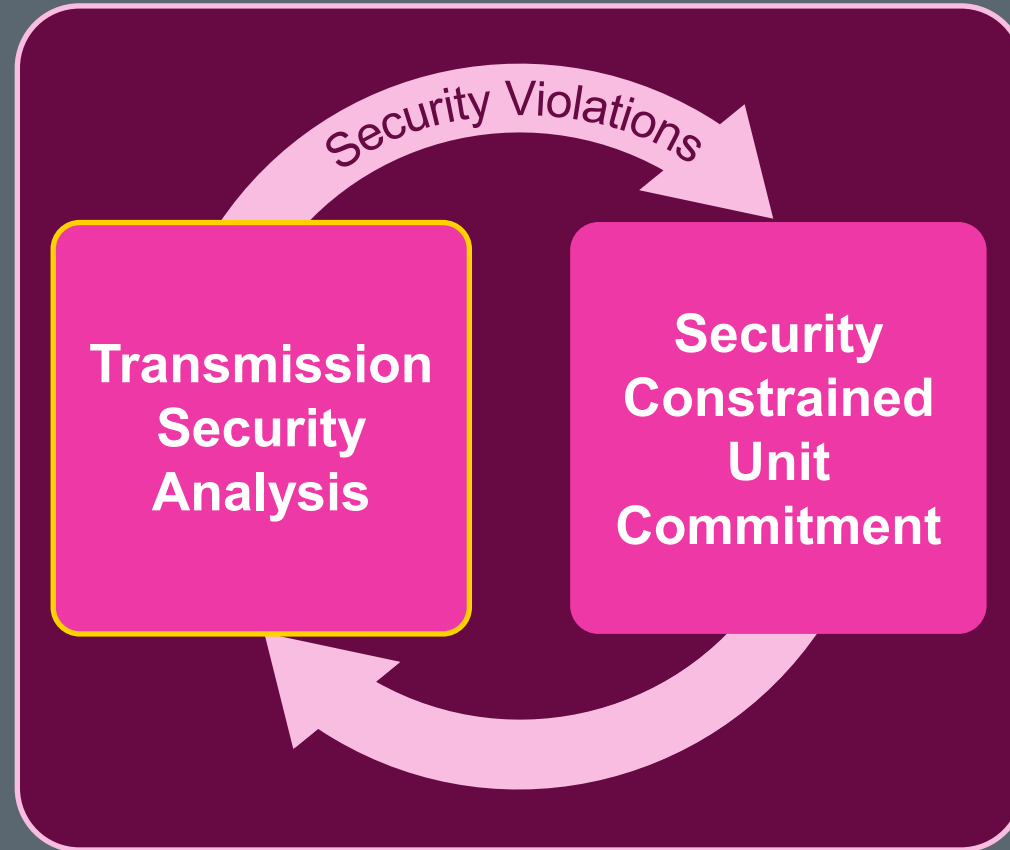

Revise Unit Commitment if needed

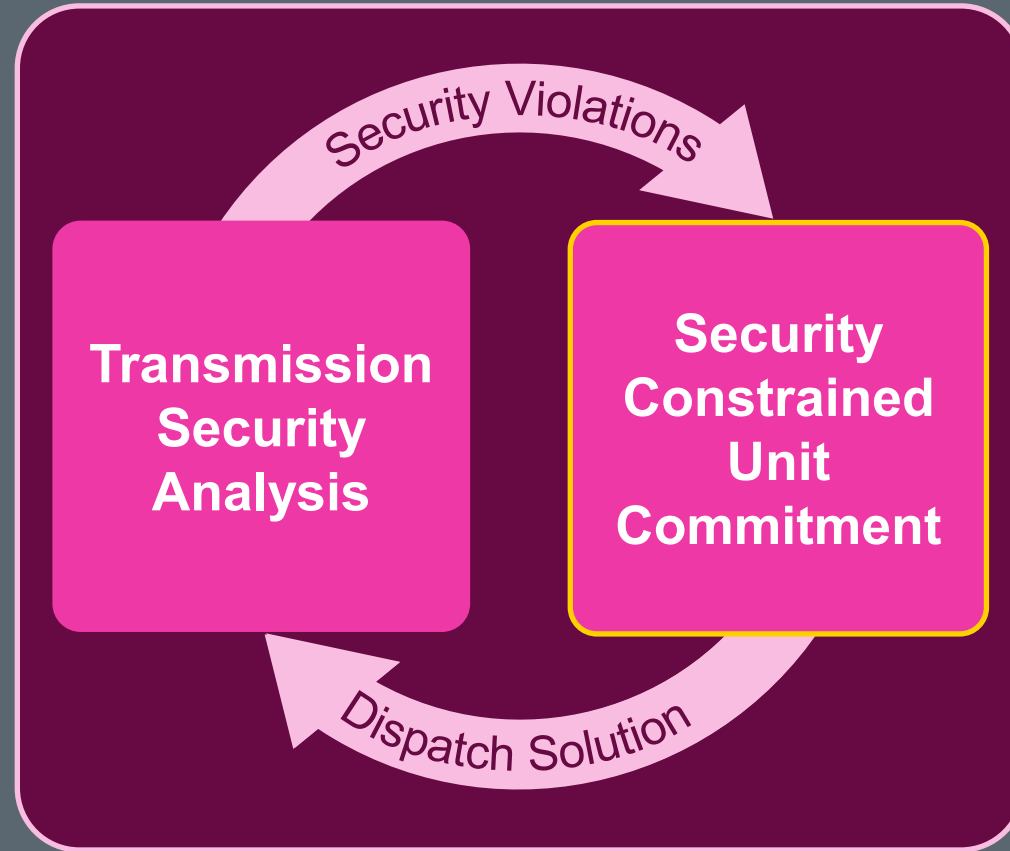

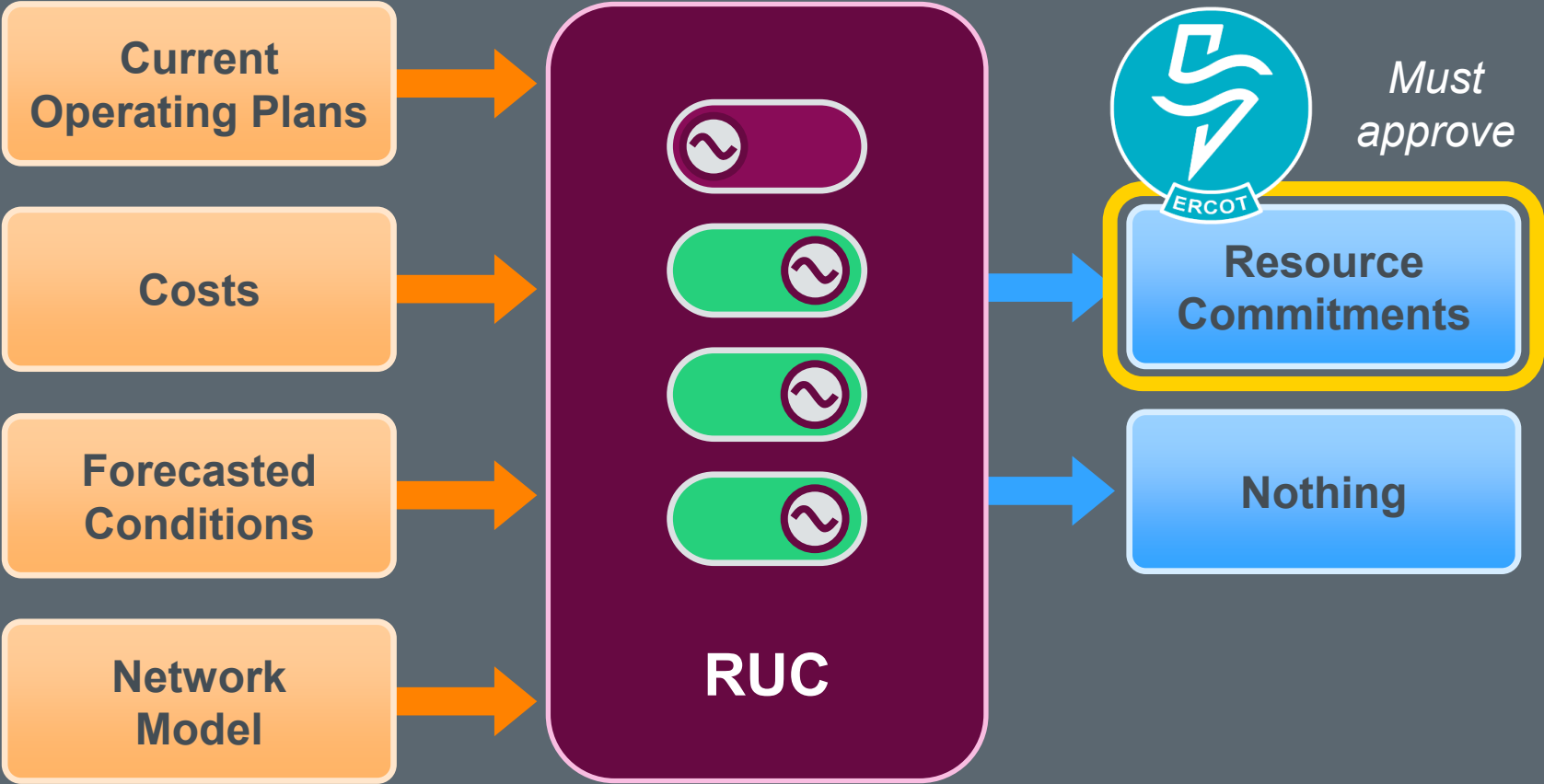

Start hour and duration sent to QSEs

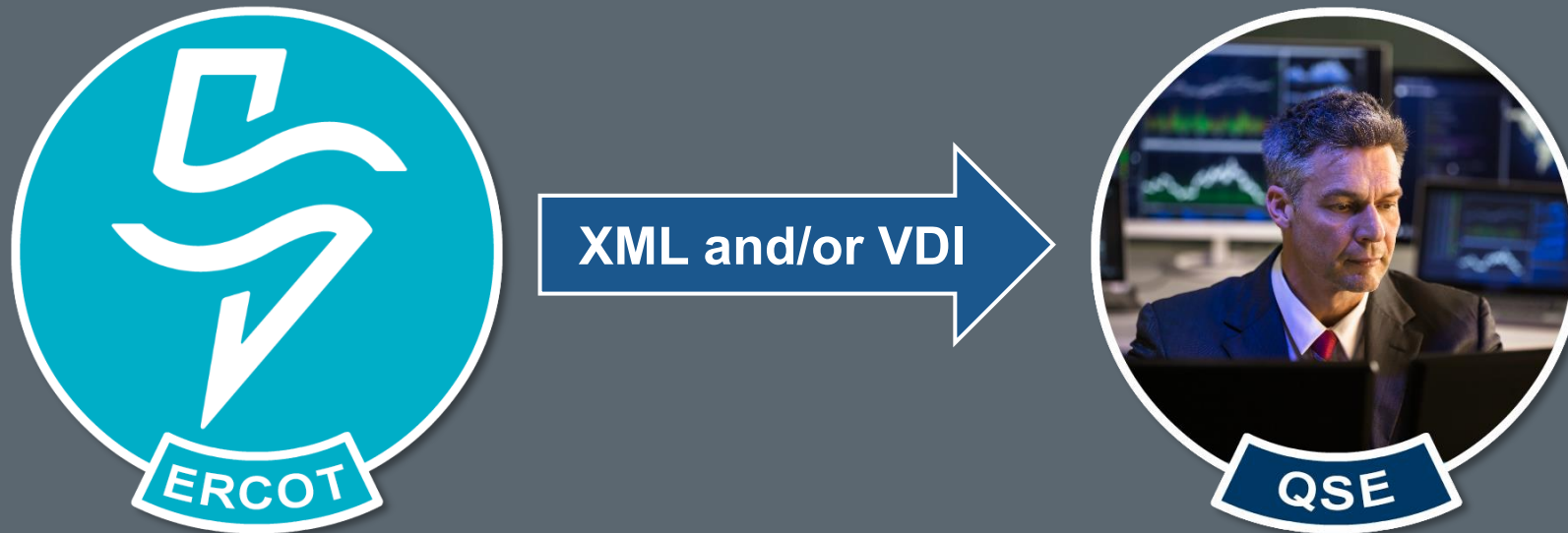

XML = Extensible Mark-Up Language
VDI = Verbal Dispatch Instruction

QSE must update COP within 60 minutes

Current Operating Plan											
Resource Name	Resource Status	Resource Limits		ESR SOC Limits			Ancillary Service Capabilities				
		HSL	LSL	Min	Max	Hour Beginning	Reg-Up	Reg-Dn	Responsive	ECRS	NSRS
GEN1	ON	600	120	-	-	-	20	20	40	40	120
GEN2	OUT	100	25	-	-	-	0	0	0	0	0
ESR3	ON	40	-40	0	40	40	0	0	40	40	10
GEN3	OFF	450	100	-	-	-	0	0	0	0	0

ONRUC
 ONOPTOUT

Resource Financial Impacts

- Floor price
- RUC Settlement
 - Make-Whole
 - Clawback

ERCOT adjusts
if QSE does not

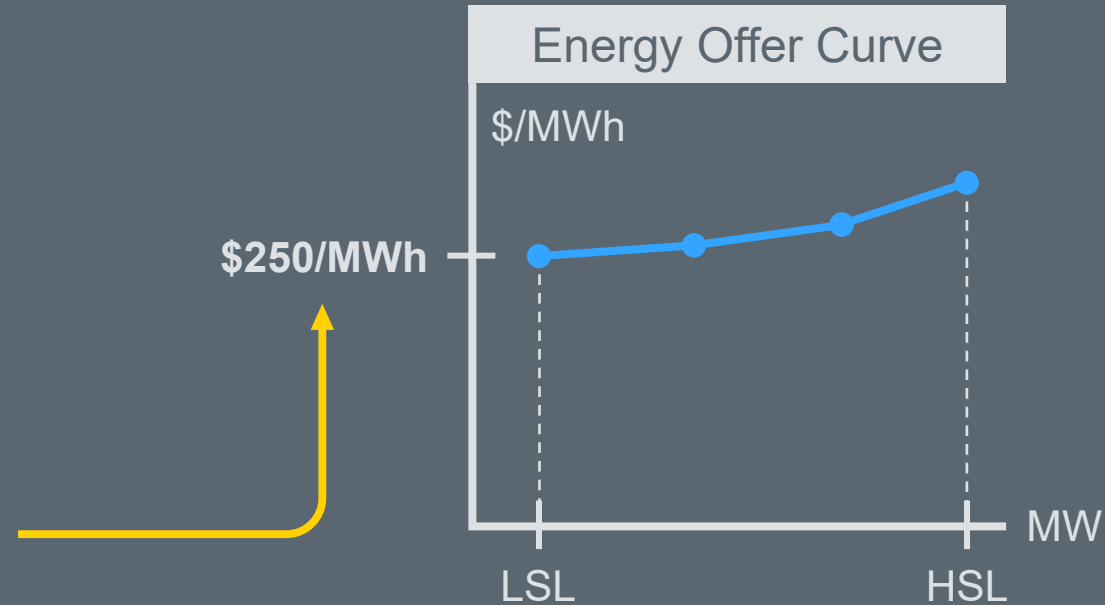

Resource Financial Impacts

- No floor price
- No RUC Settlement

QSE must update COP prior to Opt Out Snapshot

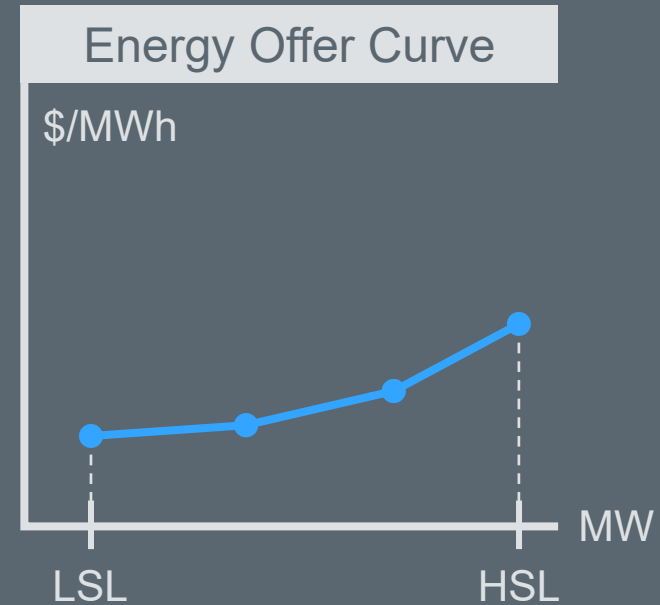

Taken at the earlier of:

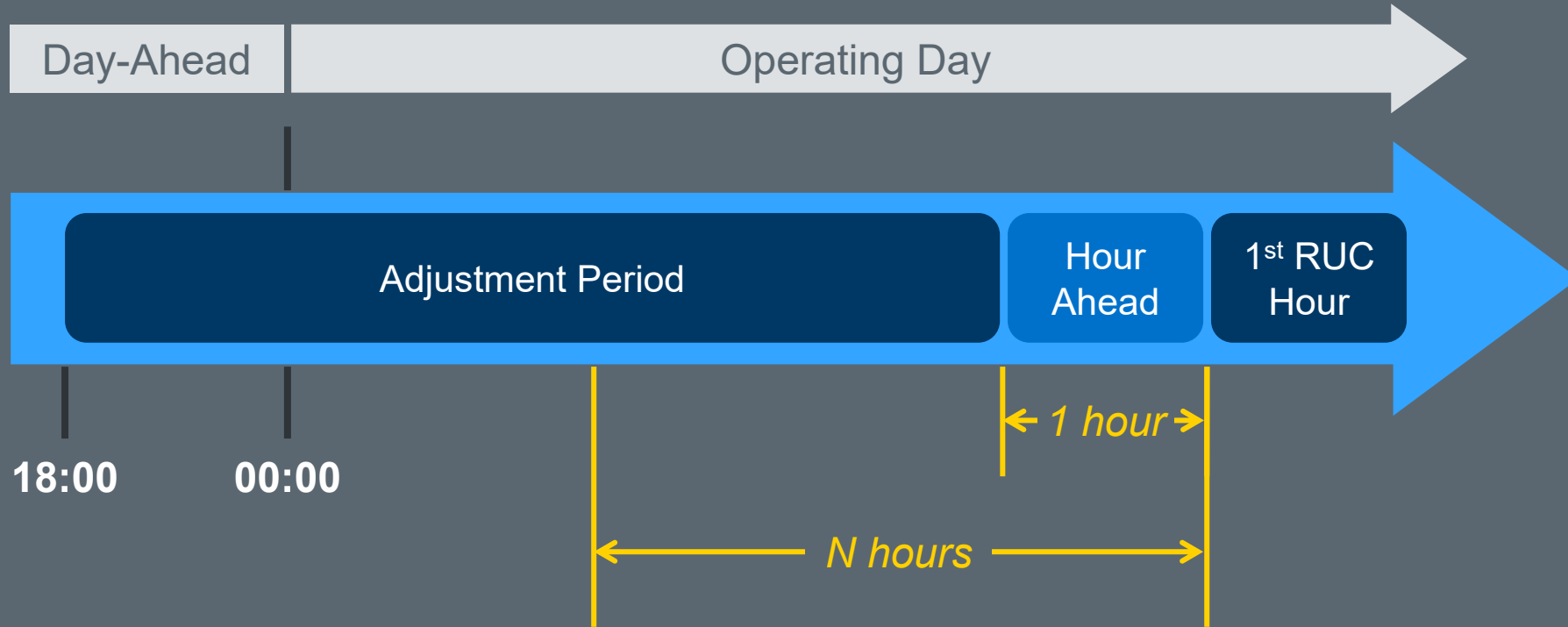

Where N is Start Time



Financial Impacts

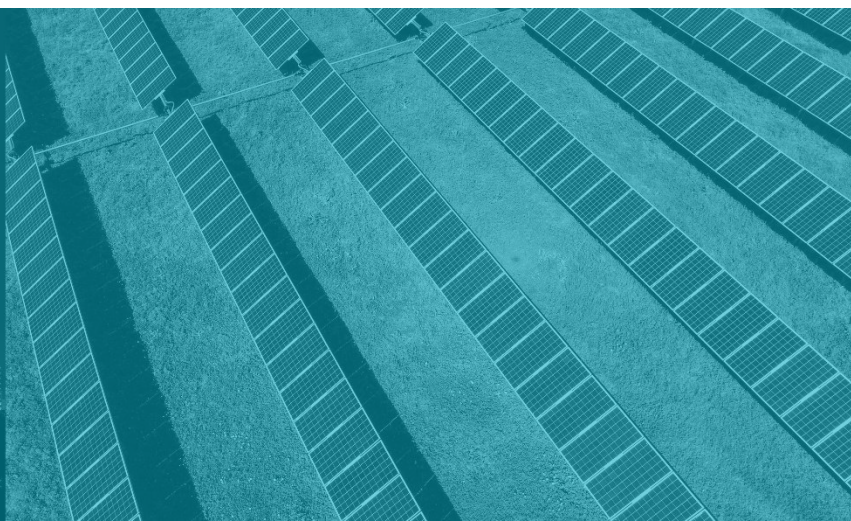



RUC
Make-Whole
Payments

RUC
Capacity Short
Charges

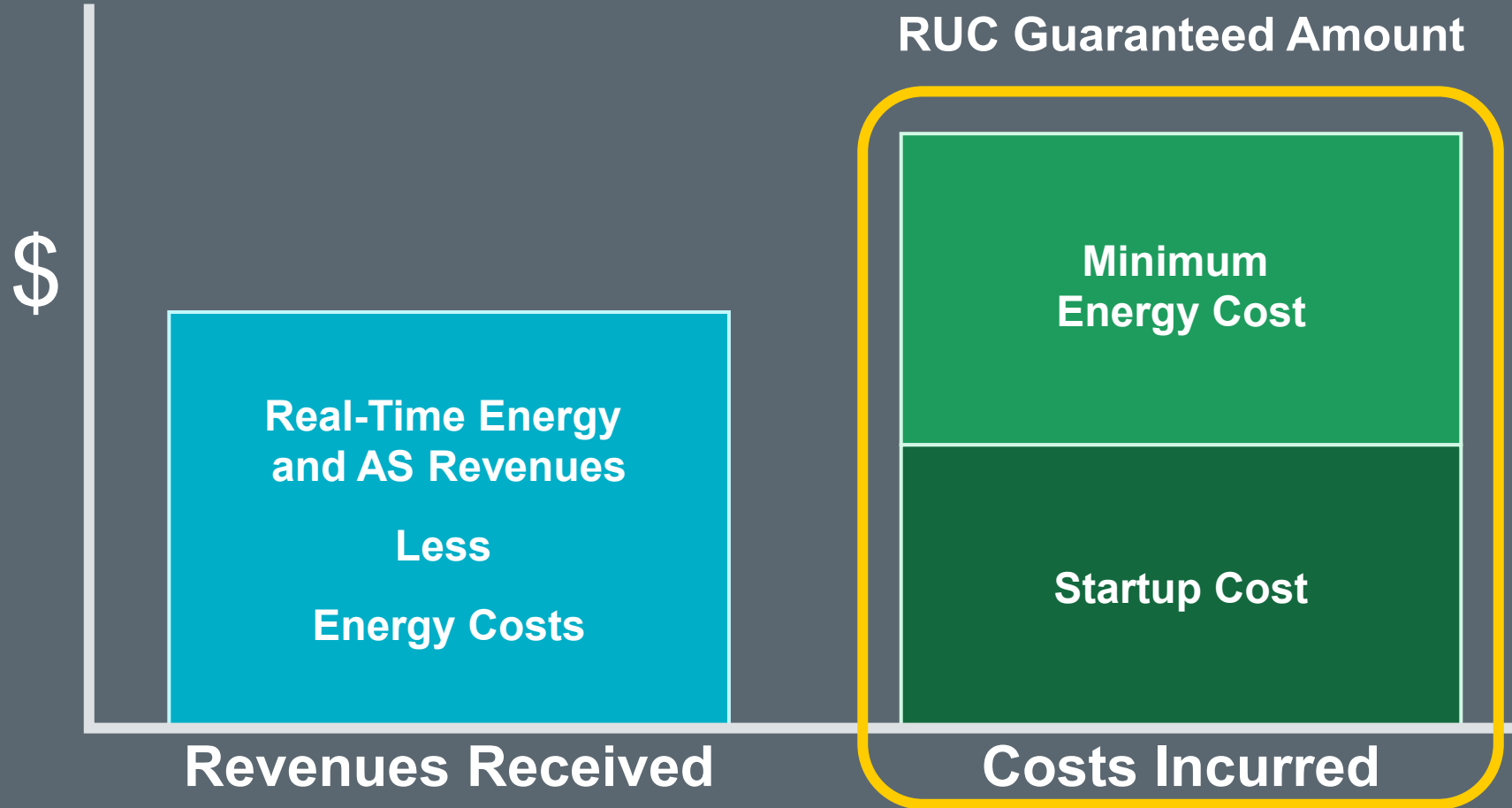

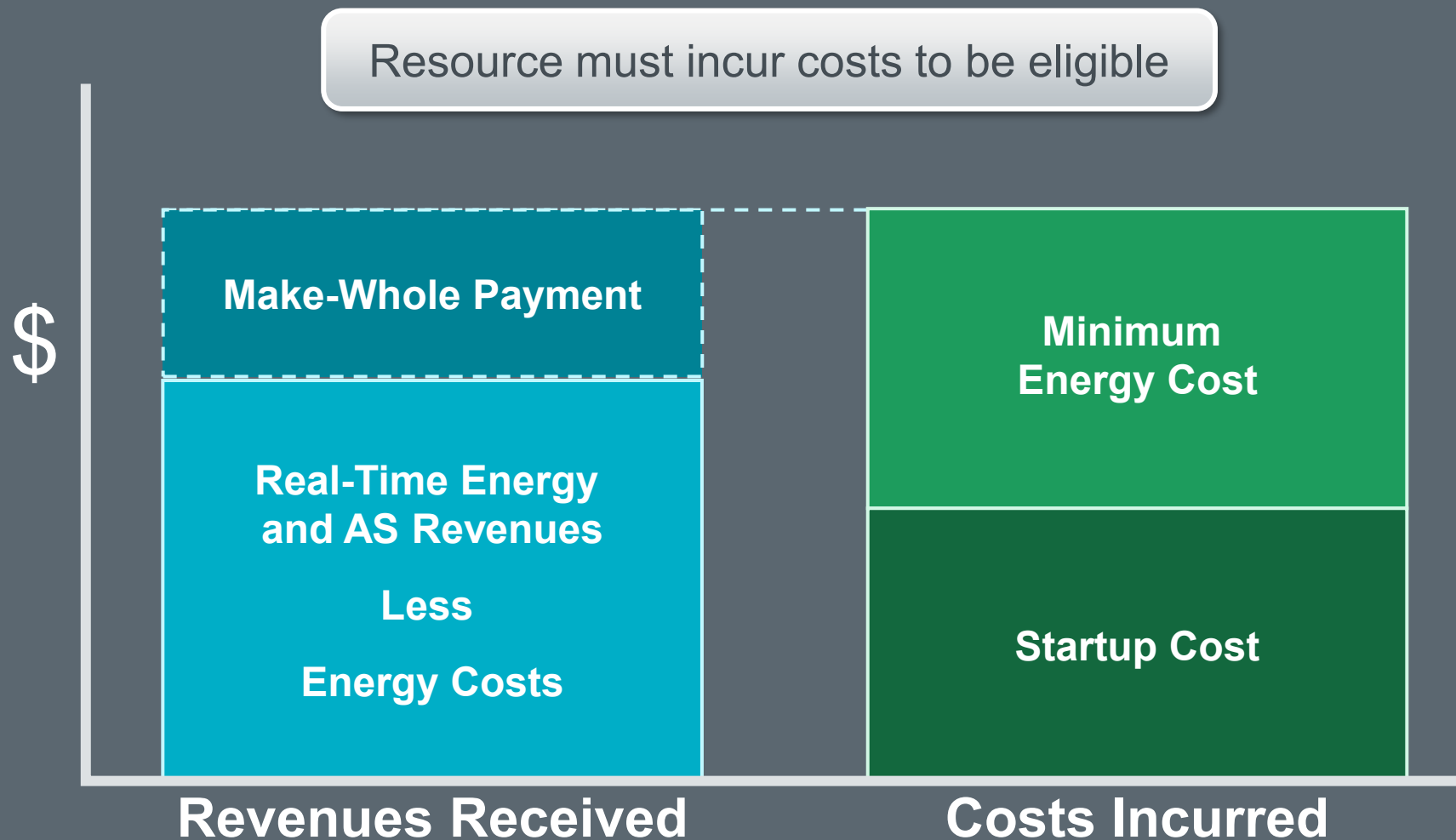



RUC
Make-Whole
Payments

RUC
Capacity Short
Charges

Assessed to QSEs with Capacity Shortfall

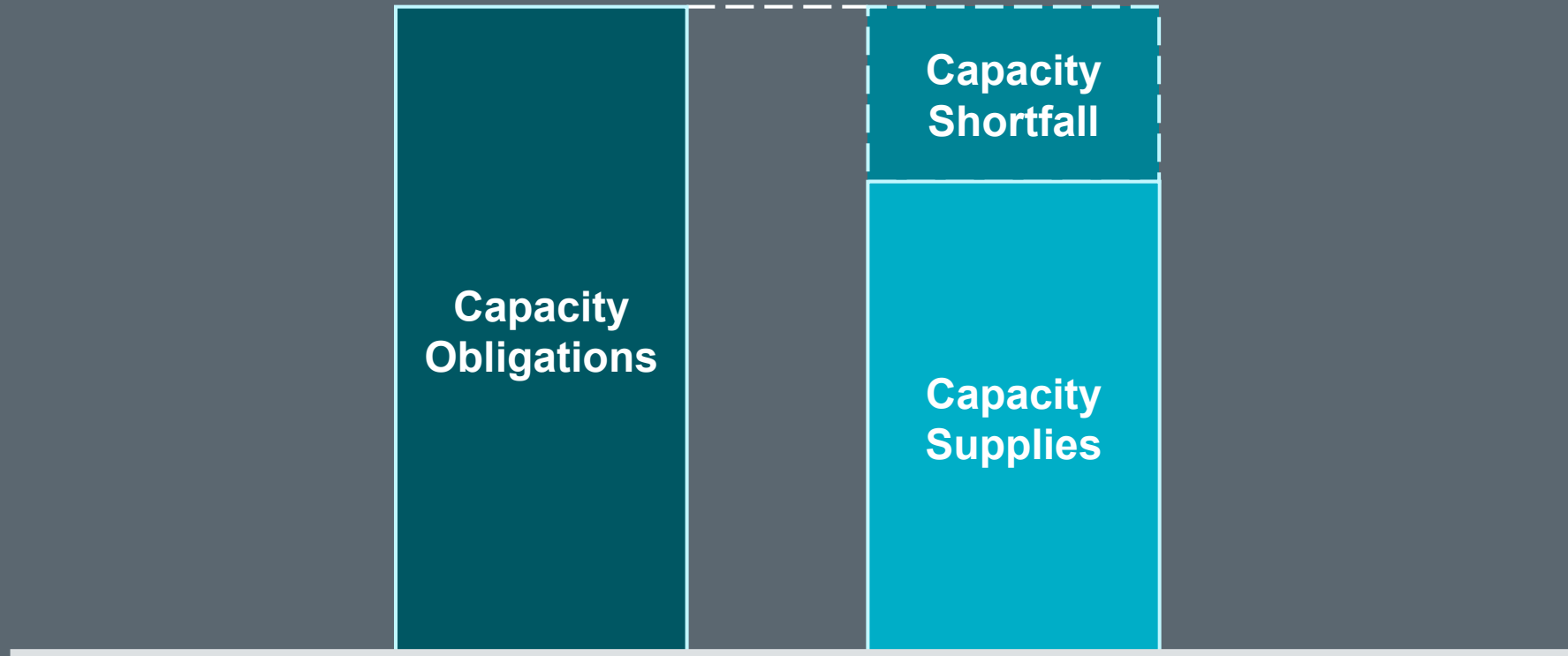

Potential Capacity Obligations for QSE



Capacity Obligations

Load

Energy Sales (DAM and Trades)

On-Line AS Sales (DAM and Trades)

Self-Arranged AS from DAM

Planned ESR charging

Potential Capacity Supplies for QSE



Committed Resource Capacity

Energy Purchases (DAM and Trades)

On-Line AS Purchases (DAM and Trades)

AS from Load Resources

Planned ESR discharging & ESR upward AS





QSE's transactions for Hour 18

- Sold 40 MW Responsive in DAM
- Sold 70 MW ECRS through Trade
- Sold 400 MW Energy in DAM



Current Operating Plan											
Resource Name	Resource Status	Resource Limits		ESR SOC Limits			Ancillary Service Capabilities				
		HSL	LSL	Min	Max	Hour Beginning	Reg-Up	Reg-Dn	Responsive	ECRS	NSRS
GEN1	ON	600	120	-	-	-	0	0	40	40	0
GEN2	OFF	450	100	-	-	-	0	0	20	30	0
ESR3	OUT	40	-40	0	40	40	0	0	40	40	10

Two Ways for QSE to be Capacity Short

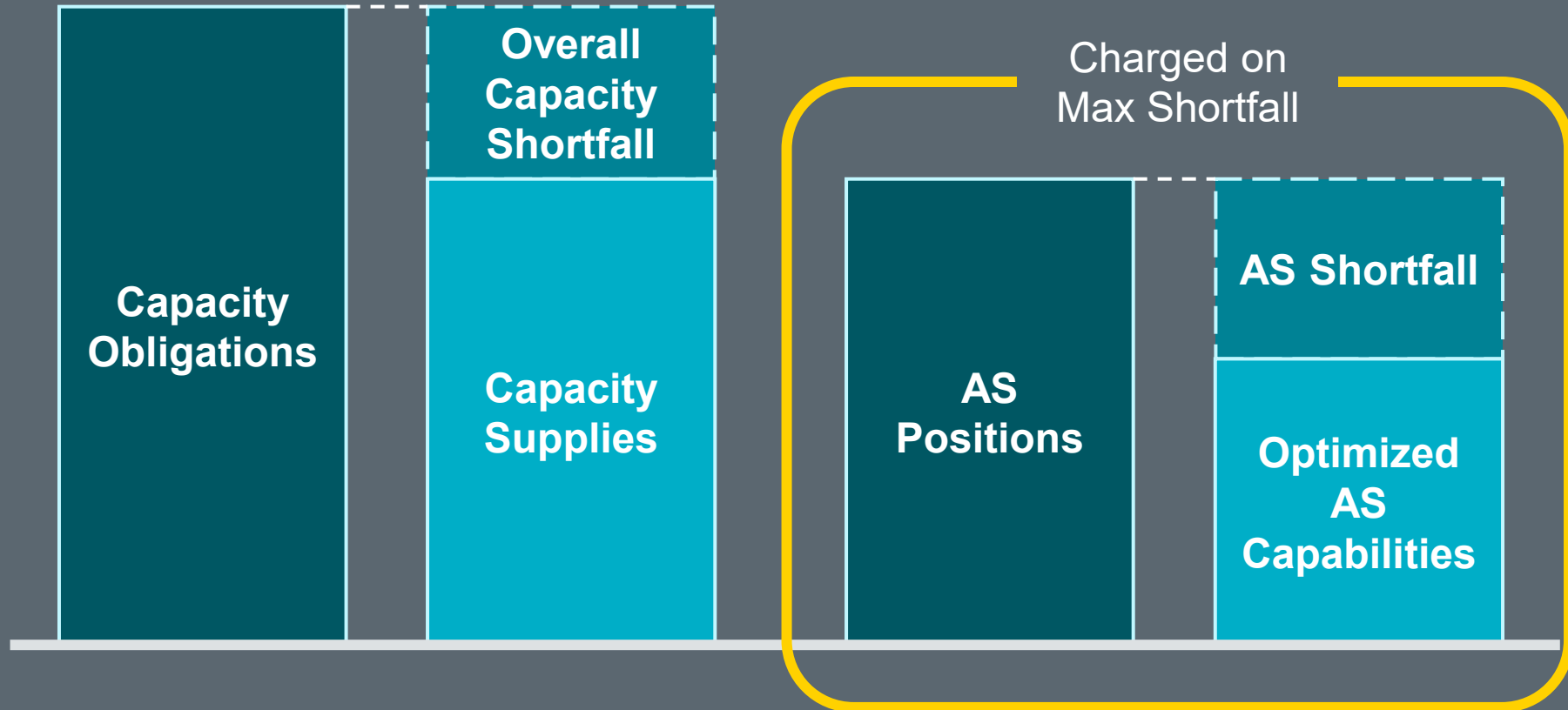

Ancillary Service Financial Obligations for QSE



**Ancillary
Service
Positions**

DAM Self-Arranged AS

+

DAM AS Awards

+

AS Trade Sales

-

AS Trade Purchases

Ancillary Service Supply for QSE



Capabilities prioritized for AS

Constraints:

- Resource Limits
- SOC (ESRs)
- Duration Requirement (ESRs)
- Deployment Factors (ESRs)

Optimized
Ancillary
Service
Capabilities



QSE's transactions for Hour 18

- Sold 40 MW Responsive in DAM
- Sold 70 MW ECRS through Trade
- Sold 400 MW Energy in DAM



Current Operating Plan											
Resource Name	Resource Status	Resource Limits		ESR SOC Limits			Ancillary Service Capabilities				
		HSL	LSL	Min	Max	Hour Beginning	Reg-Up	Reg-Dn	Responsive	ECRS	NSRS
GEN1	ON	600	120	-	-	-	0	0	40	40	0
GEN2	ON	450	100	-	-	-	0	0	20	30	0
ESR3	OUT	40	-40	0	40	40	0	0	40	40	10

**Each QSE with a Capacity Shortfall
pays a share of total Make-Whole cost**



$$\text{Charge} = \left(\text{RUC Capacity Shortfall Ratio Share} \right) * \left(\text{RUC Make-Whole Payment Total} \right)$$

Subject to a cap

$$\text{Charge} = 2 * \left(\text{RUC Capacity Shortfall} \right) * \left(\text{\$/MW cost of RUC Make-Whole} \right)$$

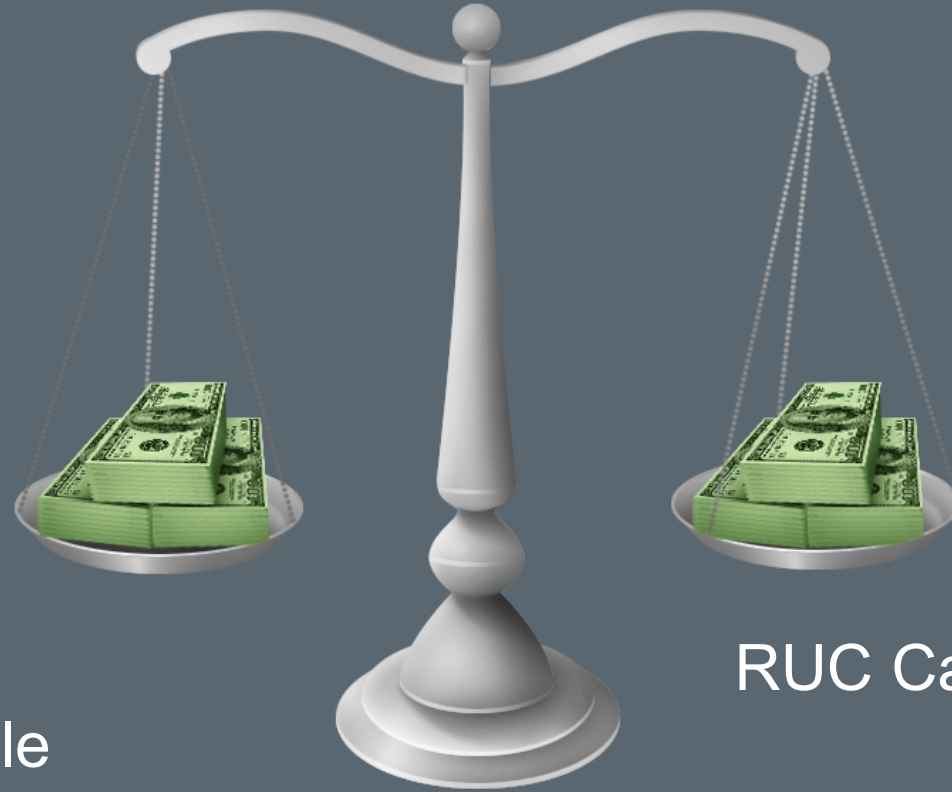

RUC
Make-Whole
Payments

RUC Capacity Short
+
Make-Whole Uplift
Charges

What if revenues are greater than costs?

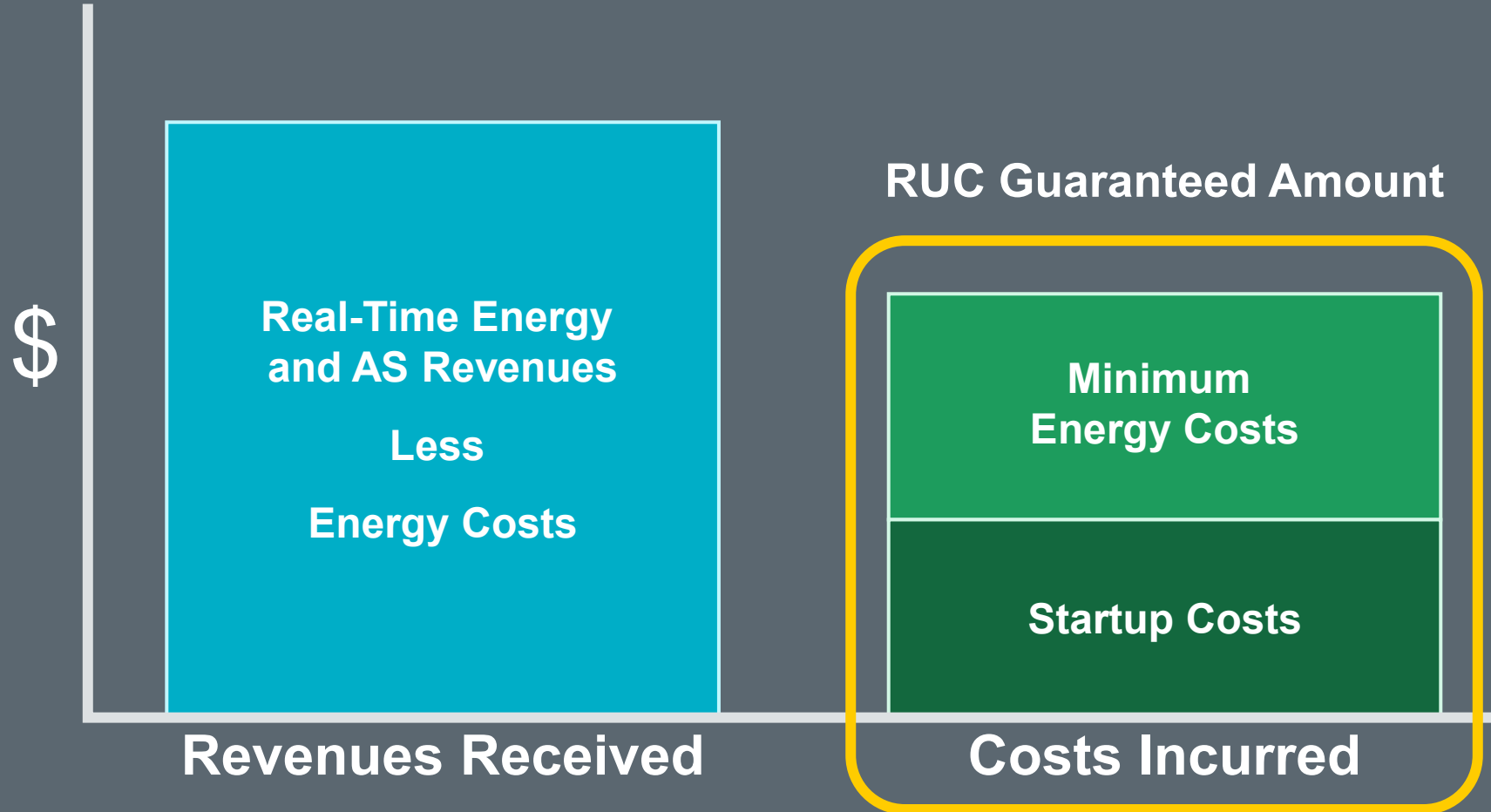

What if revenues are greater than costs?

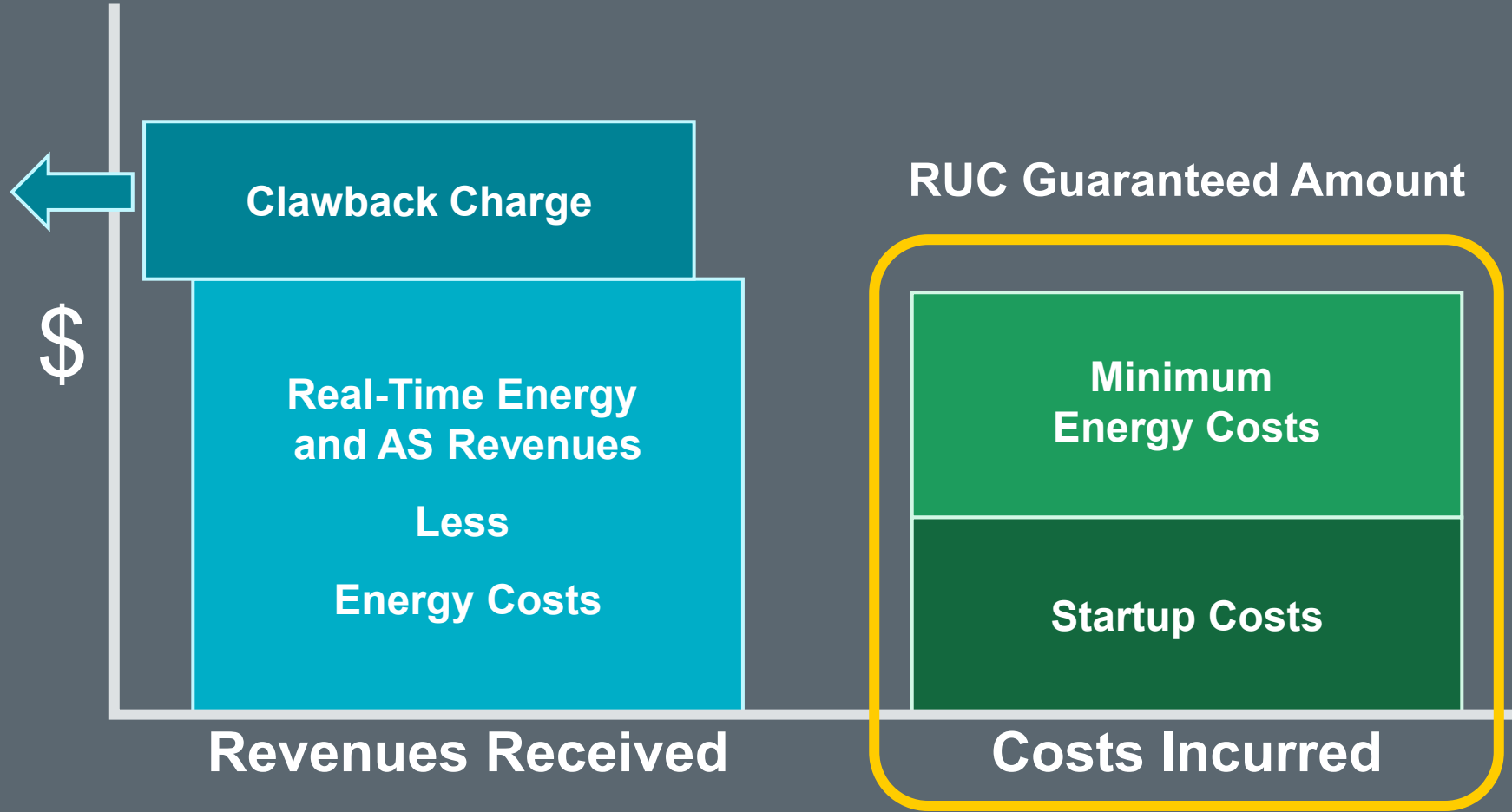



Course Wrap-Up

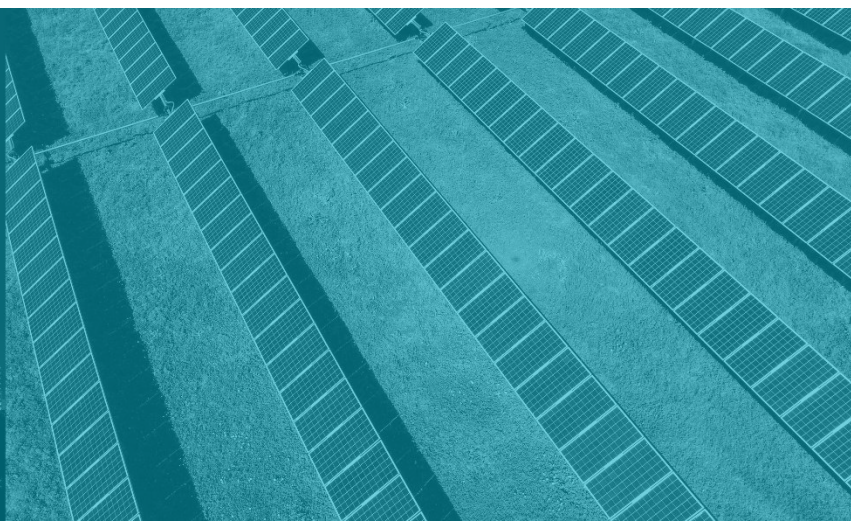

Format	Title
WBT	Wholesale Markets Overview

Format	Title	Topic
ILT	Day-Ahead Market Operations	Inputs
		Market Clearing
		Financial Impacts
	Reliability Unit Commitment	Overview
		Process
		Financial Impacts
	Real-Time Market Operations	Security Constrained Economic Dispatch
		Load Frequency Control
		Financial Impacts

ERCOT Training Information

<http://www.ercot.com/services/training/>

Course Recommendations

<https://www.ercot.com/services/training/recommendations>

Market Education Contact

Training@ercot.com

ERCOT Client Services Contact

Clientservices@ercot.com

ERCOT Mailing Lists

<http://lists.ercot.com/>

Scan this QR code to take the course survey!

<https://www.surveymonkey.com/r/ERCOTILT>

