

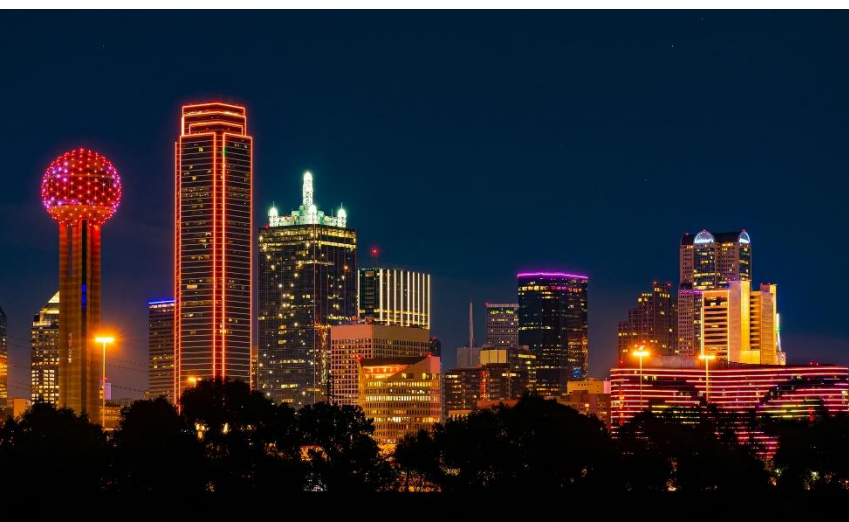

# Day-Ahead Market Operations



2026\_04 Day-Ahead Market Operations

Greetings  
and  
Introductions

**Attendance**

**Questions**

**Presentation Materials**



## PROTOCOL DISCLAIMER

This presentation provides a general overview of the Texas Nodal Market and is not intended to be a substitute for the ERCOT Protocols, as amended from time to time. If any conflict exists between this presentation and the ERCOT Protocols, the ERCOT Protocols shall control in all respects.

For more information, please visit:

<http://www.ercot.com/mktrules/nprotocols/>

Format	Title
WBT	Wholesale Markets Overview

Format	Title	Topic
ILT	Day-Ahead Market Operations	Inputs
		Market Clearing
		Financial Impacts
	Reliability Unit Commitment	Overview
		Process
		Financial Impacts
	Real-Time Market Operations	Security Constrained Economic Dispatch
		Load Frequency Control
		Financial Impacts

## ERCOT-Facilitated Forward Market

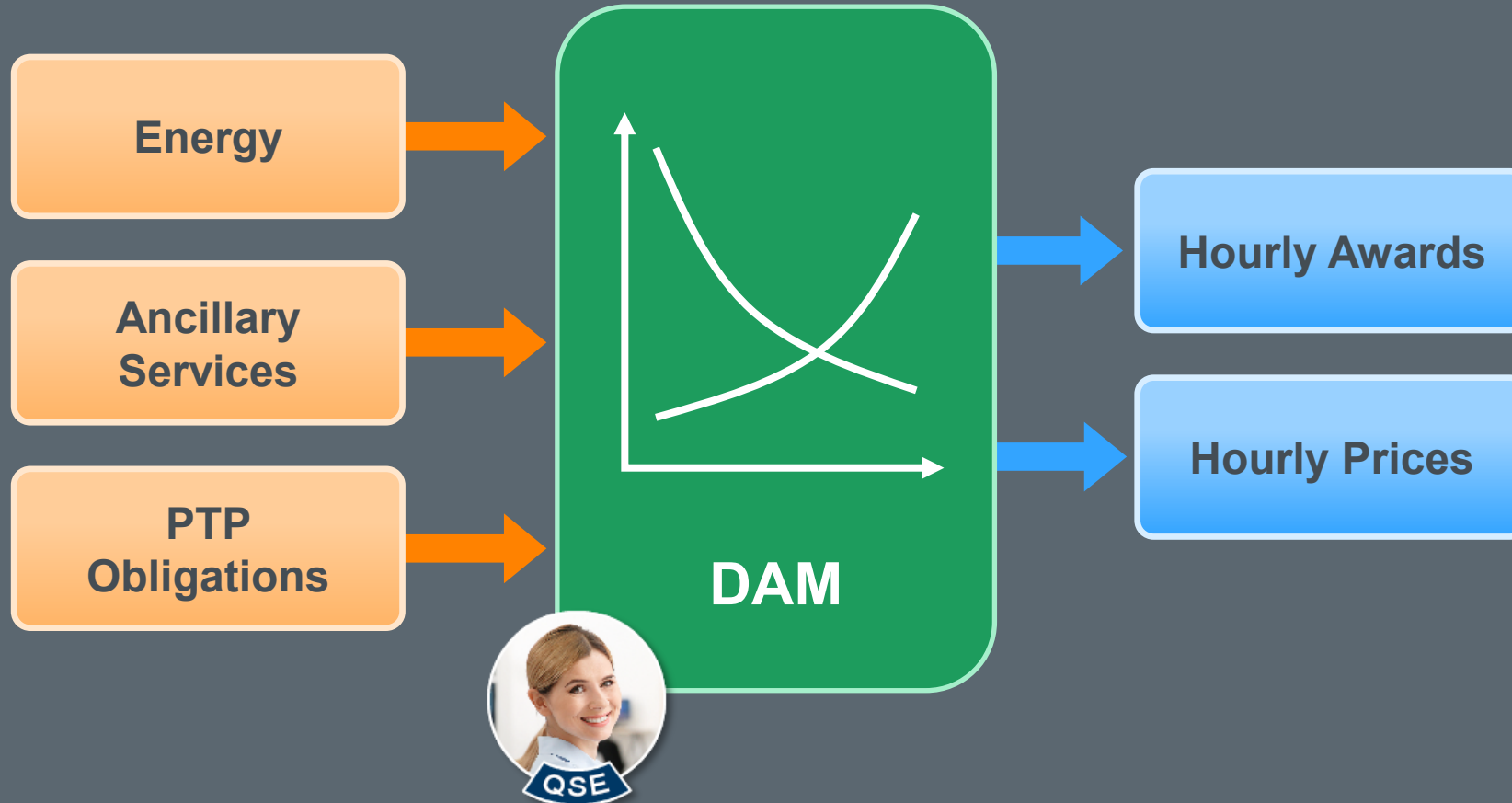

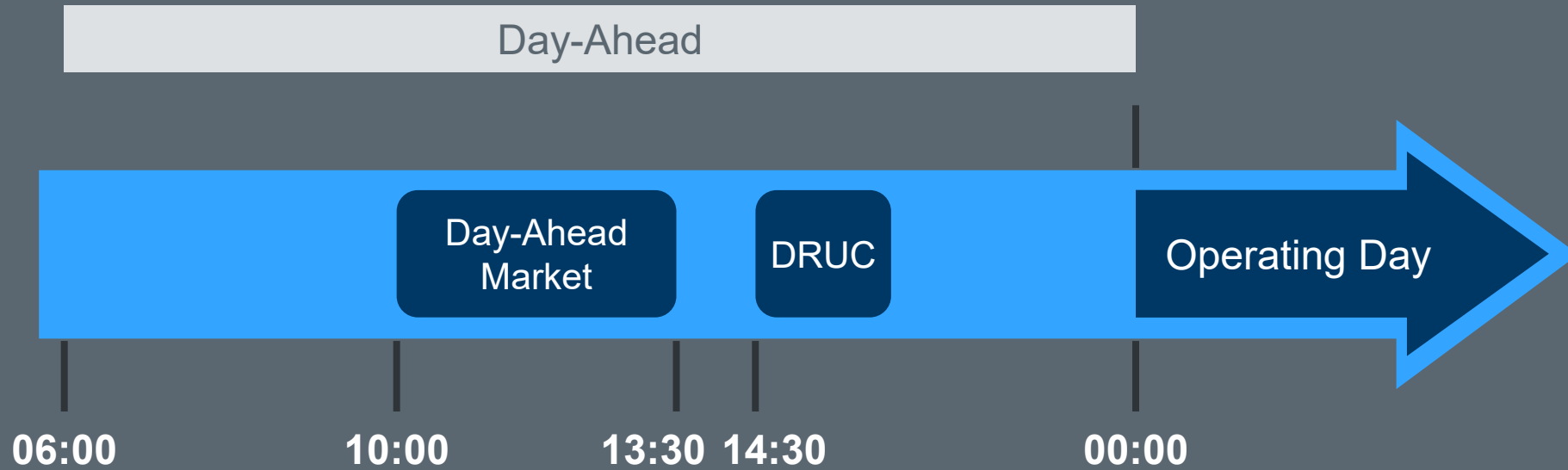

**QSEs provide Day-Ahead Market inputs by 10:00**

**ERCOT Posts Market Data by 0600**

## In accordance with PUCT Scarcity Pricing Mechanism,

ERCOT Market Caps		HCAP	LCAP*
Day-Ahead System Wide Offer Cap	DASWCAP	\$5000	\$2000
Real-Time System Wide Offer Cap	RTSWCAP	\$2000	\$2000
Value of Lost Load	VOLL	DASWCAP	

\* Used when Peaker Net Margin exceeds annual threshold



# Day-Ahead Market Inputs

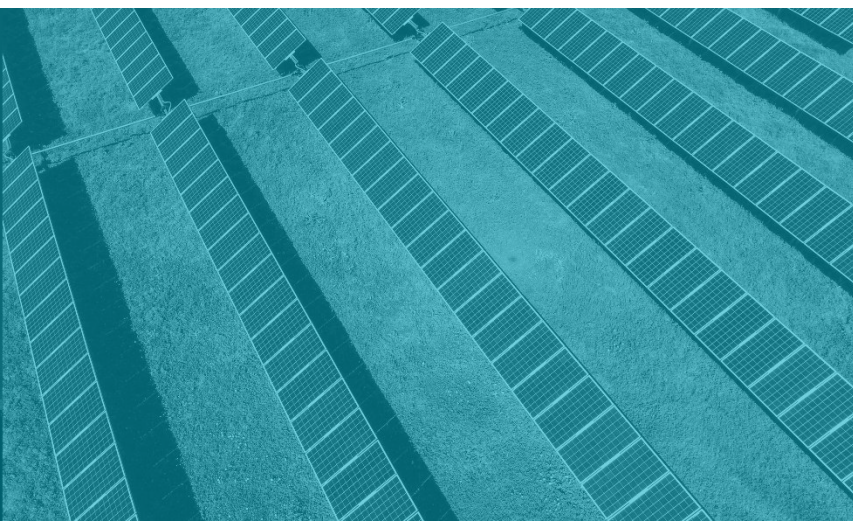

## QSEs and ERCOT provide economic Inputs

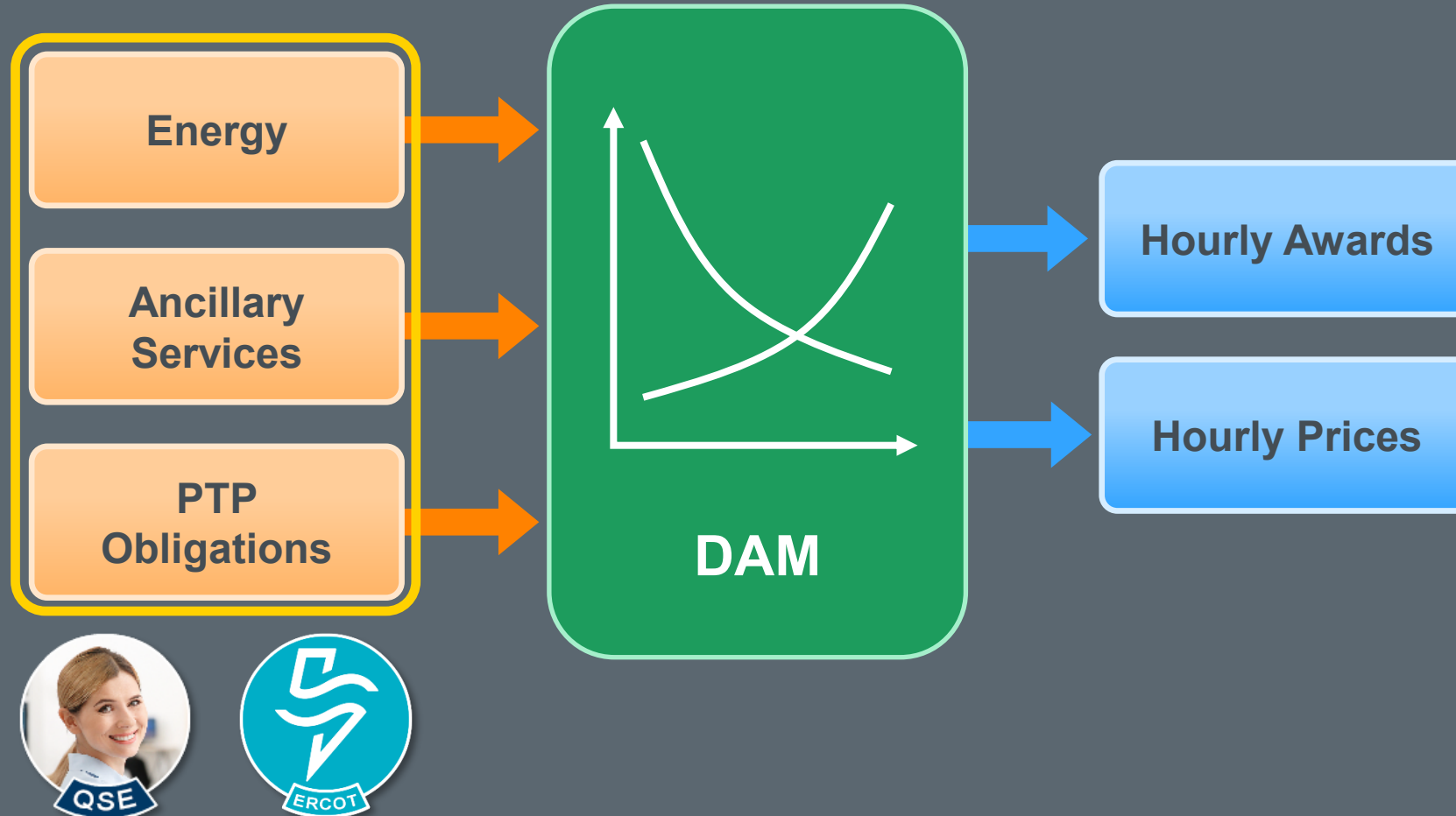



**QSE**

Energy Inputs	Ancillary Service Inputs	PTP Obligation Inputs
Energy Bids	Self-Arranged AS Quantities	PTP Obligation Bids
Energy-Only Offers	AS-Only Offers	
Resource-Specific Energy Offers	Resource-Specific AS Offers	
Current Operating Plans		



**ERCOT**

Ancillary Service Inputs
AS Demand Curves

**DAM Energy Bid**

Proposal to **buy** energy:

- Quantity
- Price
- Settlement Point

**DAM Energy-Only Offer**

Proposal to **sell** energy:

- Quantity
- Price
- Settlement Point



## Purely Financial Transactions





## Purely Financial Transactions

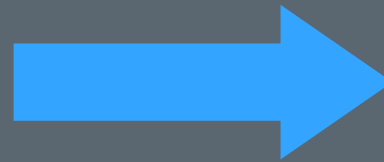

## Curve with up to 10 Price/Quantity Pairs

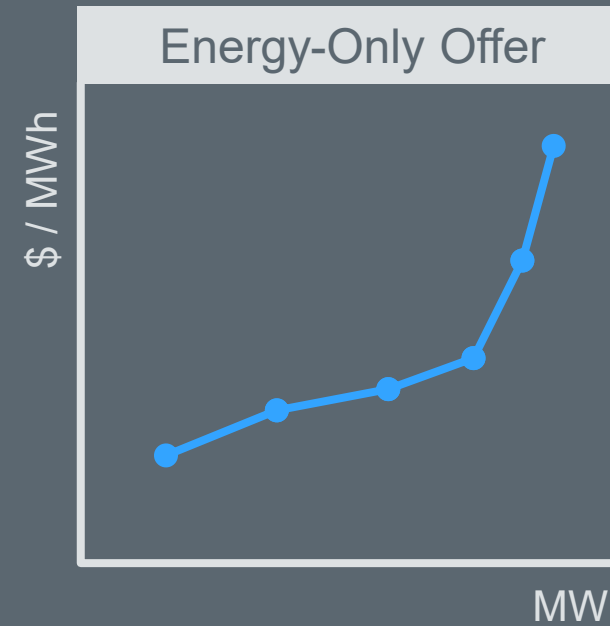
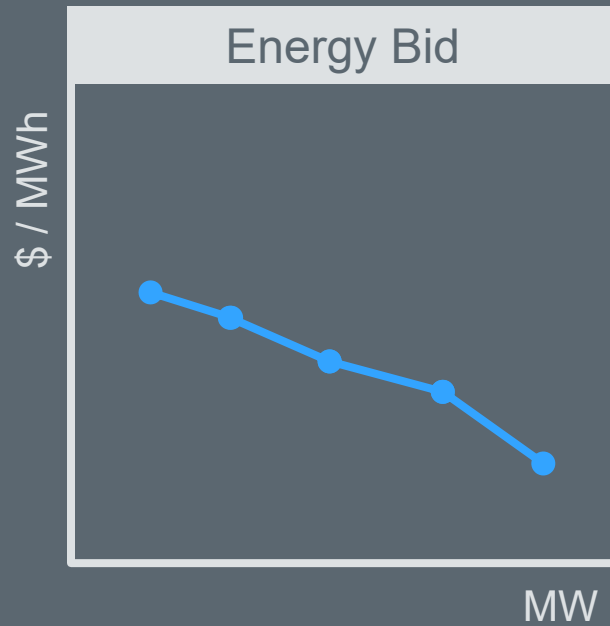

## Block with Single Price/Quantity Pair

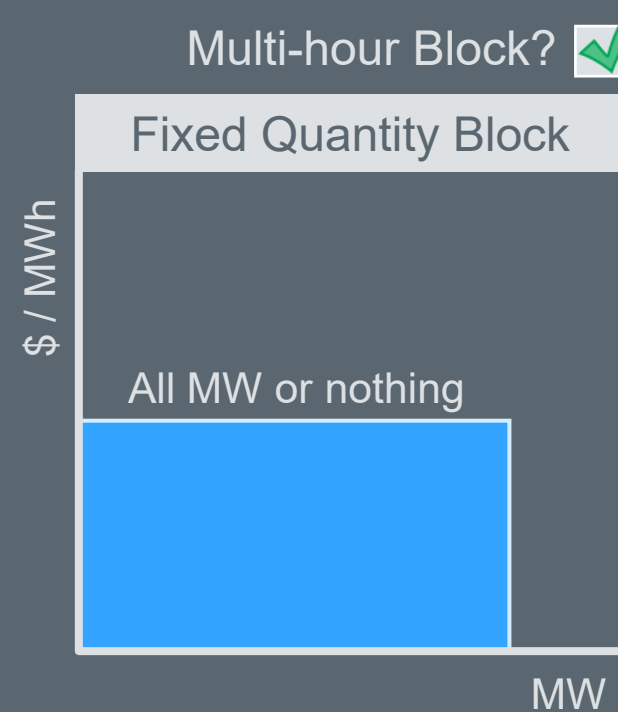
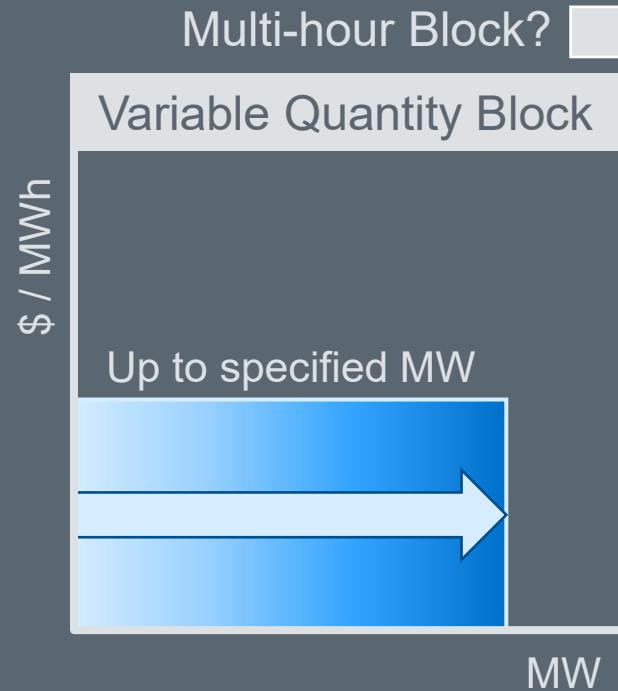



## QSE submits the following Energy Bid for 0700-2200

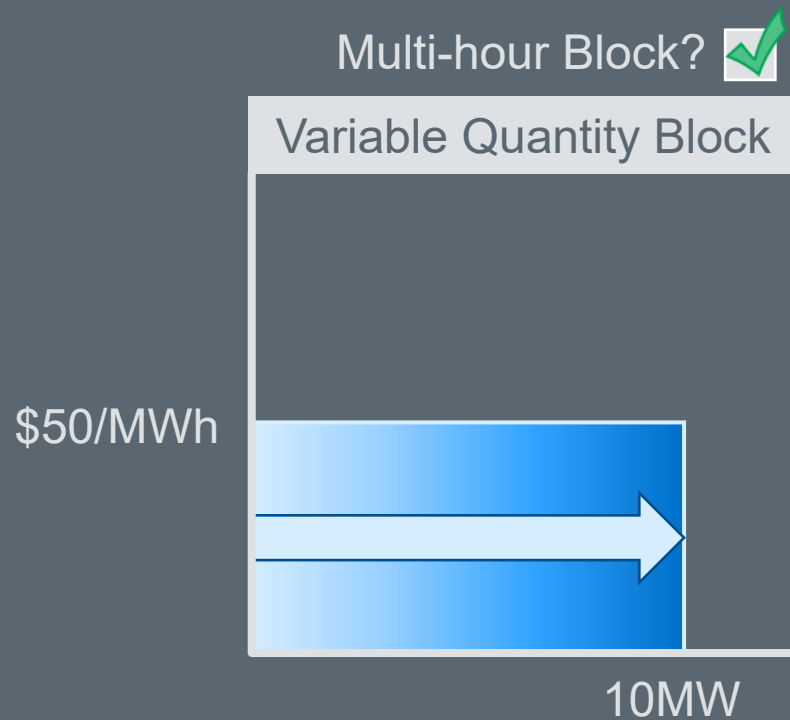

*Day-Ahead Market Options?*



## QSE submits the following Energy Bid for 0700-2200

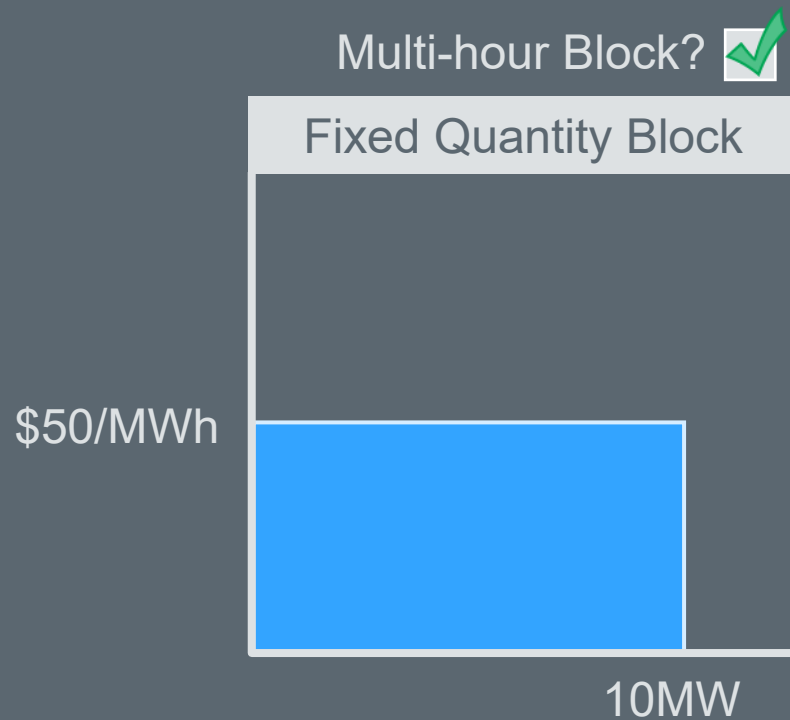

*Day-Ahead Market Options?*

Fixed Block price will not set clearing price



**QSE**

Energy Inputs	Ancillary Service Inputs	PTP Obligation Inputs
Energy Bids	Self-Arranged AS Quantities	PTP Obligation Bids
Energy-Only Offers	AS-Only Offers	
Resource-Specific Energy Offers	Resource-Specific AS Offers	
Current Operating Plans		



**ERCOT**

Ancillary Service Inputs
AS Demand Curves

# Energy Offer from Generation Resource

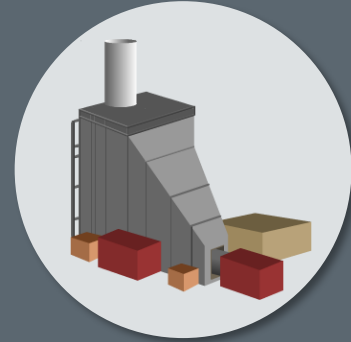

LSL – Low Sustained Limit  
HSL – High Sustained Limit

## Where are the three parts used?

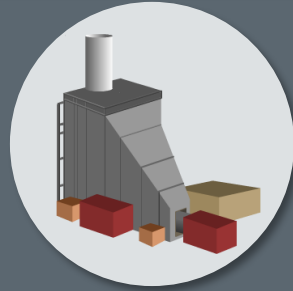

	Three-Part Supply Offer		
	Startup Offer	Minimum Energy Offer	Energy Offer Curve
Day-Ahead Market	✓	✓	✓
RUC-Commitment	✓	✓	
Real-Time Dispatch			✓



## Energy “Offer” from an Energy Storage Resource

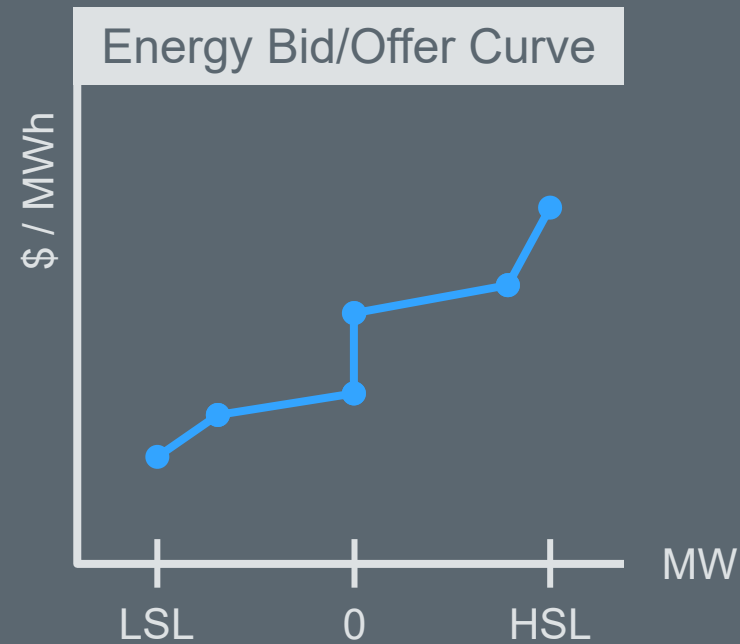

HSL = High Sustained Limit  
LSL = Low Sustained Limit



**QSE**



**ERCOT**

Energy Inputs	Ancillary Service Inputs	PTP Obligation Inputs
Energy Bids	<b>Self-Arranged AS Quantities</b>	PTP Obligation Bids
Energy-Only Offers	AS-Only Offers	
Resource-Specific Energy Offers	Resource-Specific AS Offers	
Current Operating Plans		

Ancillary Service Inputs
AS Demand Curves

## A QSE may have Advisory Ancillary Service Obligations

Self-Arrange

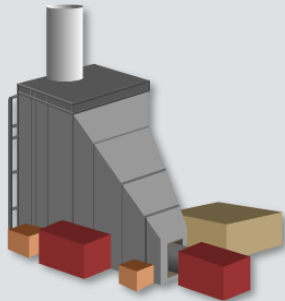

Allow ERCOT to procure

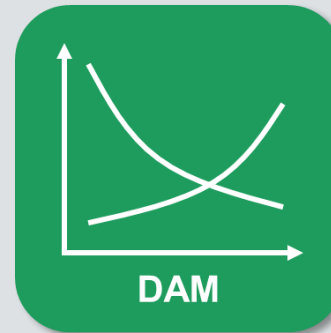

**May choose to Self-Arrange before DAM**

## QSE has Regulation Up Obligations for a range of hours

Hour	Advisory AS Obligation	Self-Arranged Quantity	Net Obligation	ERCOT action on QSE's behalf
1500	7 MW			
1600	6 MW			
1700	5 MW			
1800	3 MW			

## A Few Rules:

QSE Action	Rules
<b>Self-Arrangement</b>	May not exceed their Advisory AS Obligation per service
	Paid for Self-Arranged Quantity that exceeds their Final AS Obligation
<b>Negative Self-Arrangement</b>	Limited to Net AS Trade Sales Up to 500 MW per Service



**QSE**



**ERCOT**

Energy Inputs	Ancillary Service Inputs	PTP Obligation Inputs
Energy Bids	Self-Arranged AS Quantities	PTP Obligation Bids
Energy-Only Offers	<b>AS-Only Offers</b>	
Resource-Specific Energy Offers	Resource-Specific AS Offers	
Current Operating Plans		

Ancillary Service Inputs
AS Demand Curves

## Financial Offers for Each Service

Type of Service	Offer	
Regulation Up	MW	\$ / MW
Regulation Down	MW	\$ / MW
Responsive Reserve	MW	\$ / MW
ERCOT Contingency Reserve	MW	\$ / MW
Non-Spinning Reserve	MW	\$ / MW

**... subject to \$0 / MW price floor**



## Purely Financial Transactions





**QSE**

Energy Inputs	Ancillary Service Inputs	PTP Obligation Inputs
Energy Bids	Self-Arranged AS Quantities	PTP Obligation Bids
Energy-Only Offers	AS-Only Offers	
Resource-Specific Energy Offers	<b>Resource-Specific AS Offers</b>	
Current Operating Plans		



**ERCOT**

Ancillary Service Inputs
AS Demand Curves

## Resource-Specific Offers for Each Service

Type of Service	Offer	
Regulation Up	MW	\$ / MW
Regulation Down	MW	\$ / MW
Responsive Reserve	MW	\$ / MW
ERCOT Contingency Reserve	MW	\$ / MW
Non-Spinning Reserve	MW	\$ / MW

**... subject to \$0 / MW price floor**

## Block with Single Price/Quantity Pair

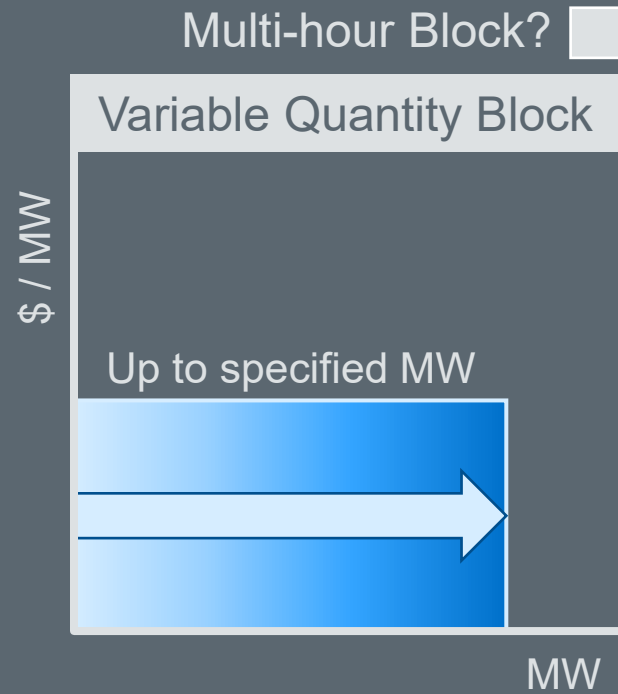

*Any qualified Resource*

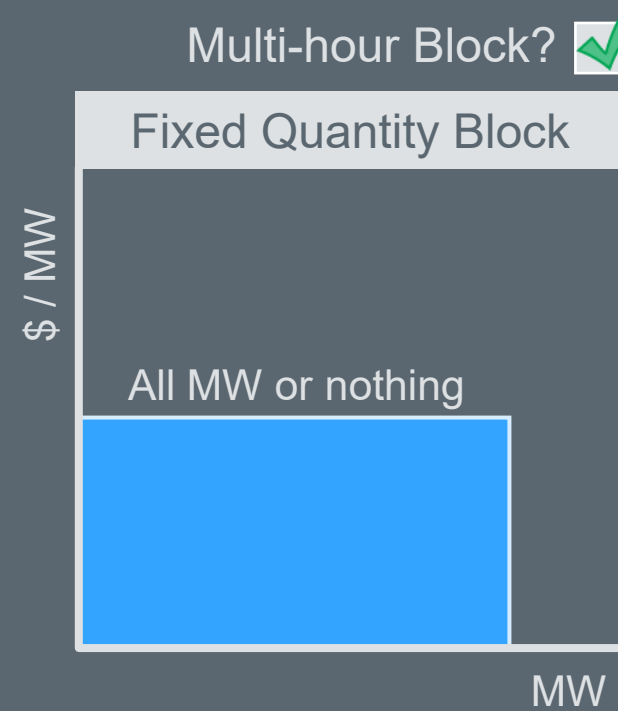

*Load Resources Only*



**QSE**

Energy Inputs	Ancillary Service Inputs	PTP Obligation Inputs
Energy Bids	Self-Arranged AS Quantities	PTP Obligation Bids
Energy-Only Offers	AS-Only Offers	
Resource-Specific Energy Offers	Resource-Specific AS Offers	
Current Operating Plans		



Ancillary Service Inputs
AS Demand Curves

## What does DAM need from Current Operating Plans?

Current Operating Plan											
Resource Name	Resource Status	Resource Limits		ESR SOC Limits			Ancillary Service Capabilities				
		HSL	LSL	Min	Max	Hour Beginning	Reg-Up	Reg-Dn	Responsive	ECRS	NSRS
GEN1	ON	600	120	-	-	-	20	20	40	40	120
GEN2	OFF	100	25	-	-	-	0	0	0	0	0
ESR3	ON	40	-40	0	40	40	0	0	40	20	10

## Single Resource may be offered for multiple products

AS Type	Offer	
Reg-Up	MW	\$ / MW
Reg-Down	MW	\$ / MW
Responsive	MW	\$ / MW
ECRS	MW	\$ / MW
Non-Spin	MW	\$ / MW

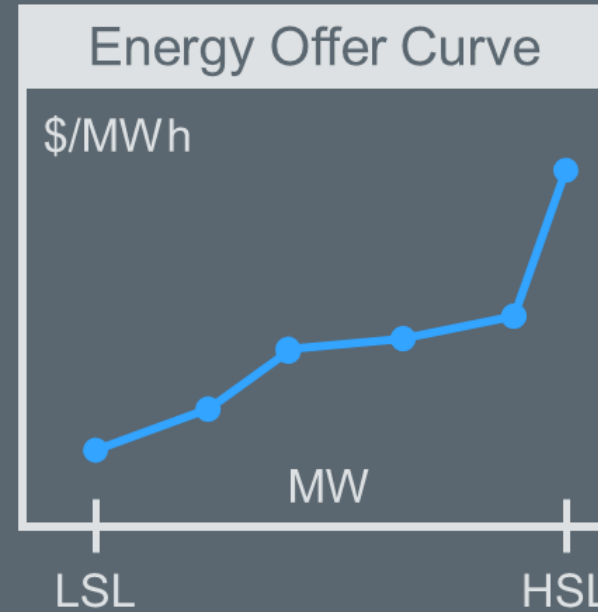

Total DAM award will not exceed Resource's Capacity

**But how would the Day-Ahead Market handle this?**

AS Type	Offer	
Reg-Up	MW	\$ / MW
Responsive	MW	\$ / MW

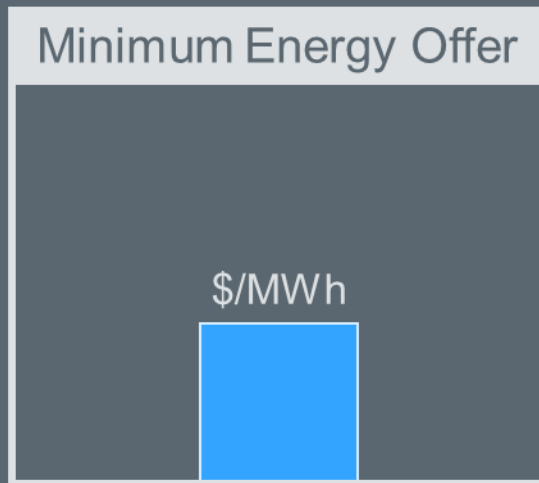



**QSE**



**ERCOT**

Energy Inputs	Ancillary Service Inputs	PTP Obligation Inputs
Energy Bids	Self-Arranged AS Quantities	PTP Obligation Bids
Energy-Only Offers	AS-Only Offers	
Resource-Specific Energy Offers	Resource-Specific AS Offers	
Current Operating Plans		

Ancillary Service Inputs
AS Demand Curves



Like a coupled Energy-Only Offer and Energy Bid

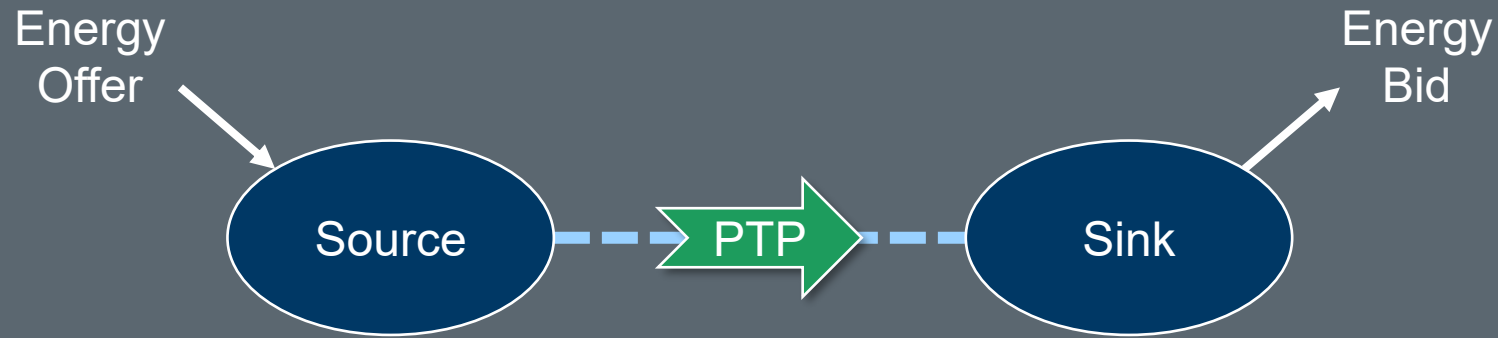

Charge (If Awarded) = ?

SPP = Settlement Point Price

## Submitted between any two Settlement Points

Source	Sink	Bid	
Hub	Load Zone	MW	\$ / MW / h
Resource Node	Load Zone	MW	\$ / MW / h
Resource Node	Hub	MW	\$ / MW / h
Load Zone	Resource Node	MW	\$ / MW / h
Load Zone	Hub	MW	\$ / MW / h

## Block with Single Price/Quantity Pair

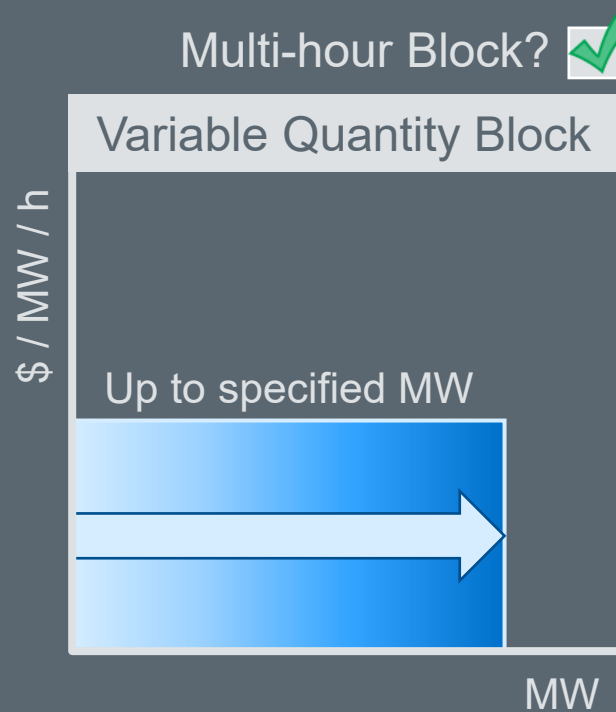



Energy Inputs	Ancillary Service Inputs	PTP Obligation Inputs
Energy Bids	Self-Arranged AS Quantities	PTP Obligation Bids
Energy-Only Offers	AS-Only Offers	
Resource-Specific Energy Offers	Resource-Specific AS Offers	
Current Operating Plans		



<b>Ancillary Service Inputs</b>
AS Demand Curves

→ *Posted by 0600 Day-Ahead*

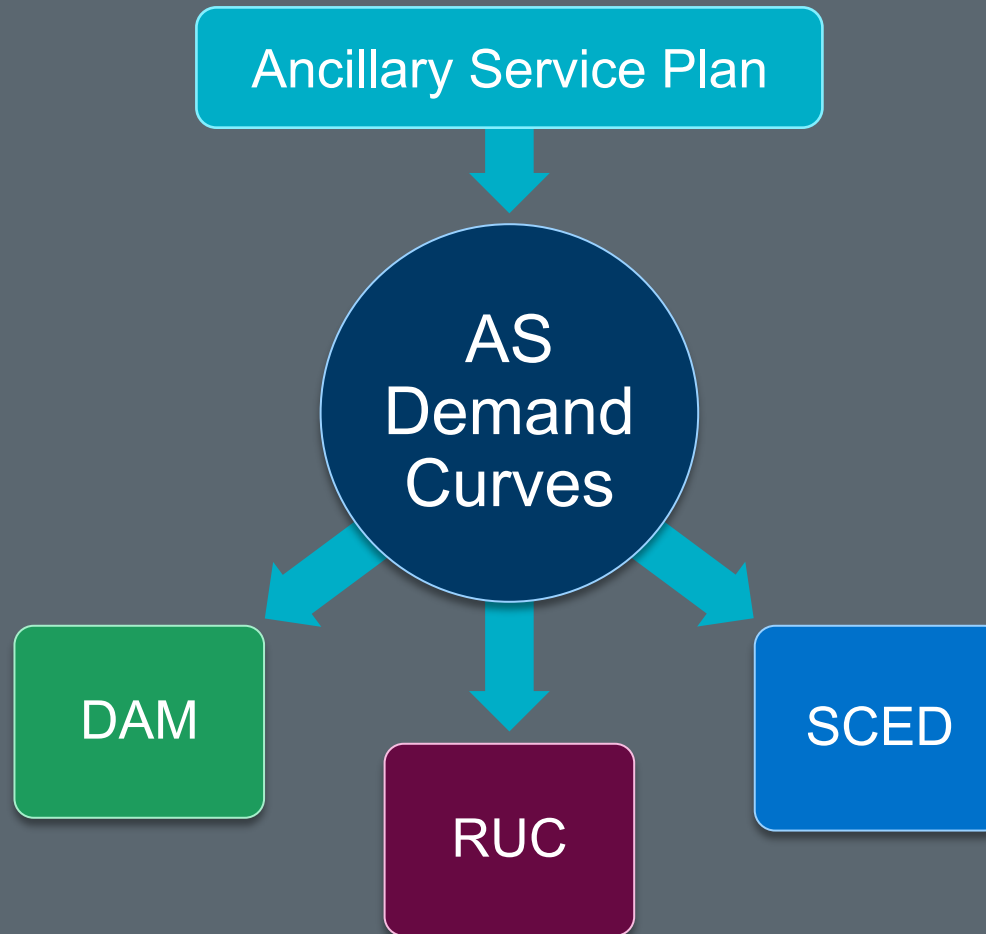

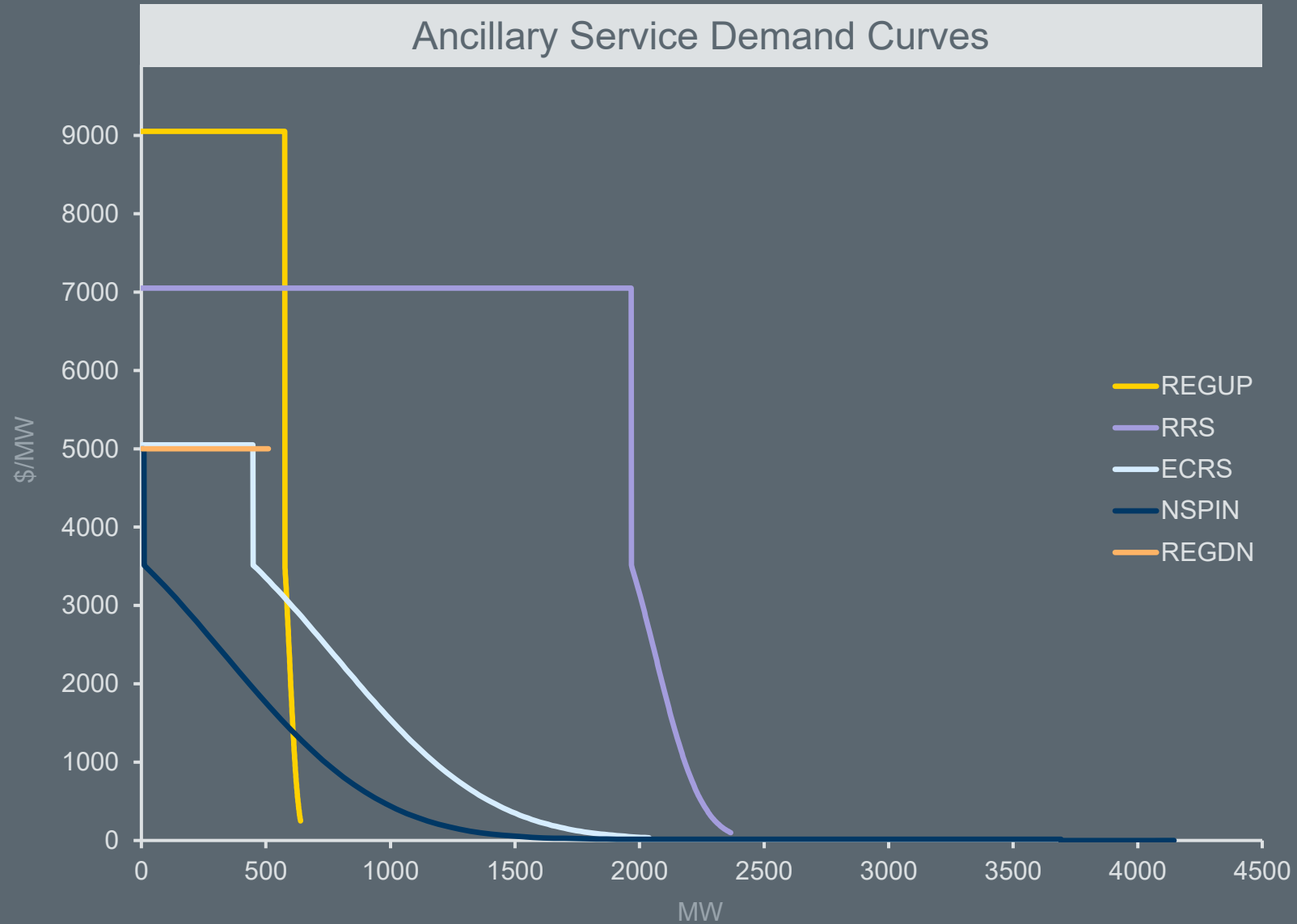



# Day-Ahead Market Clearing

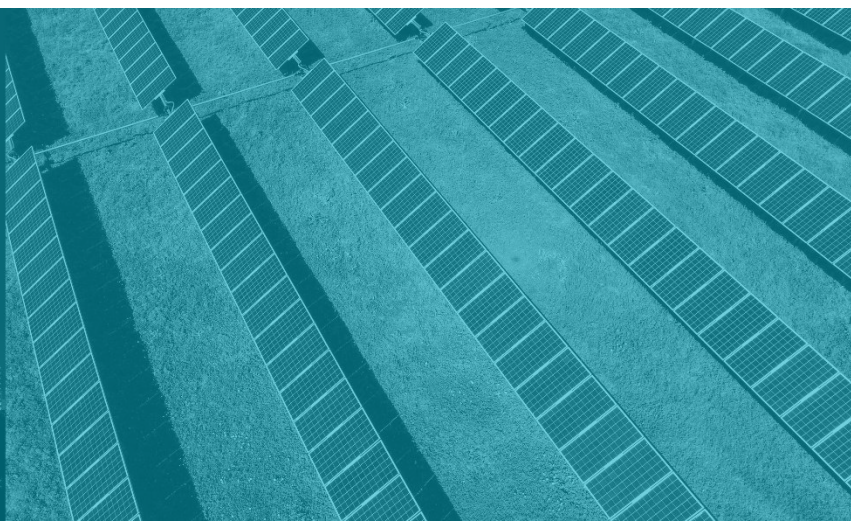

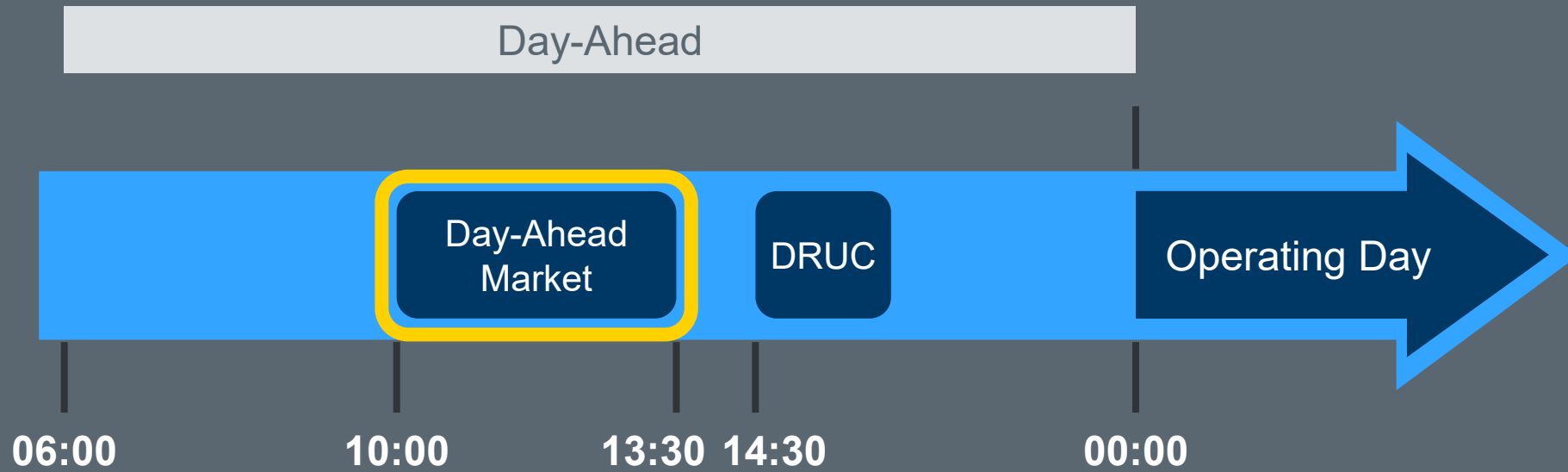

## Economically optimized subject to constraints

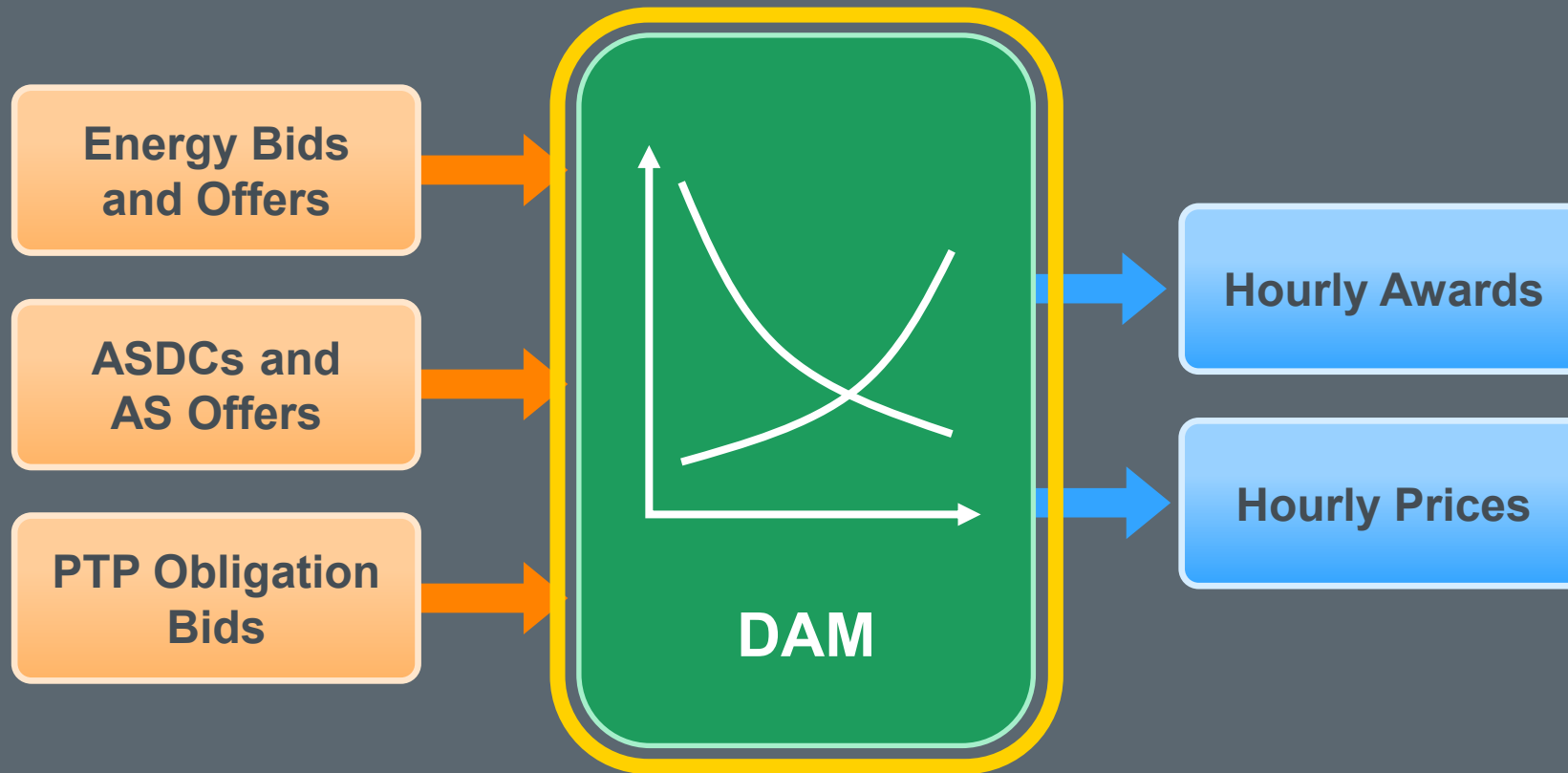

# Maximize Bid-Based Revenues minus Offer-Based Costs

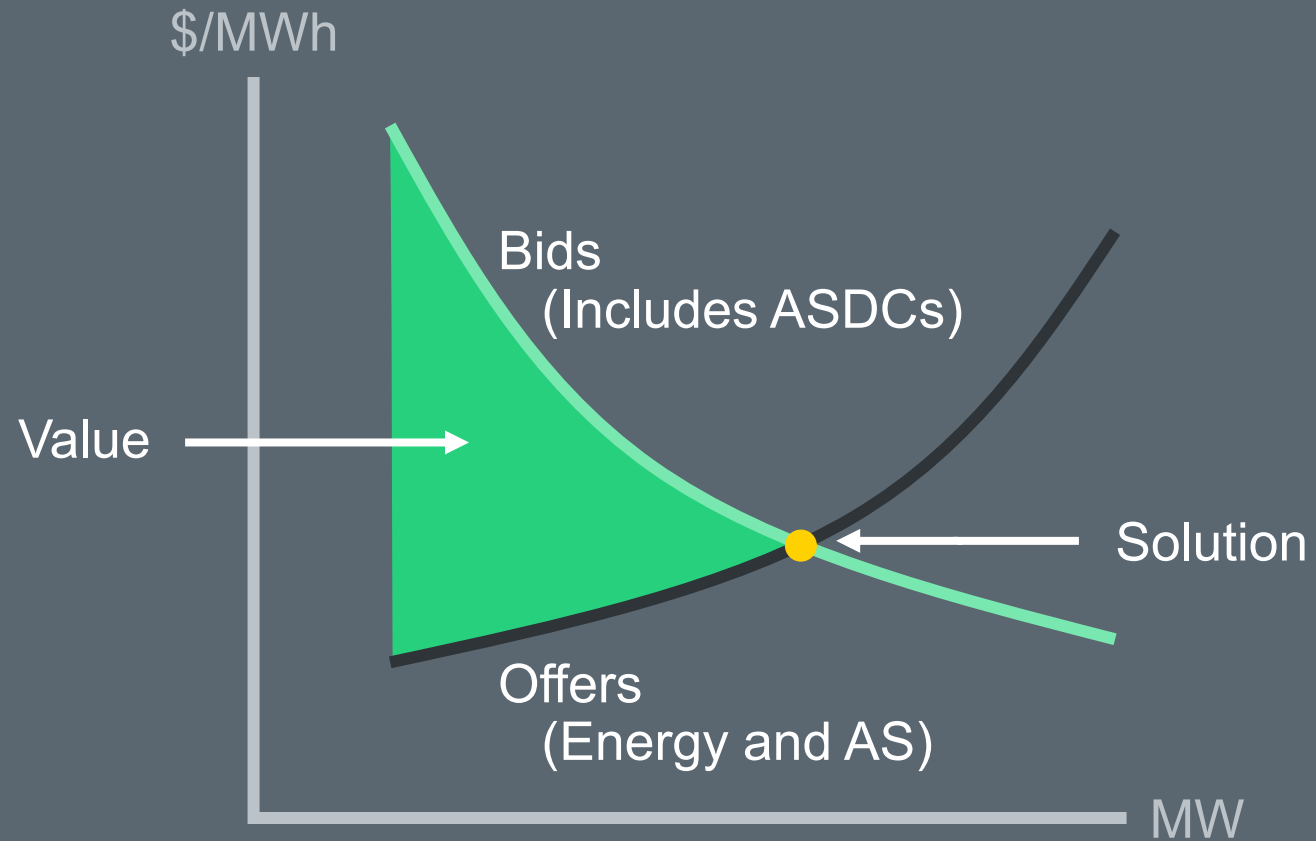

## Energy Offers must equal Energy Bids

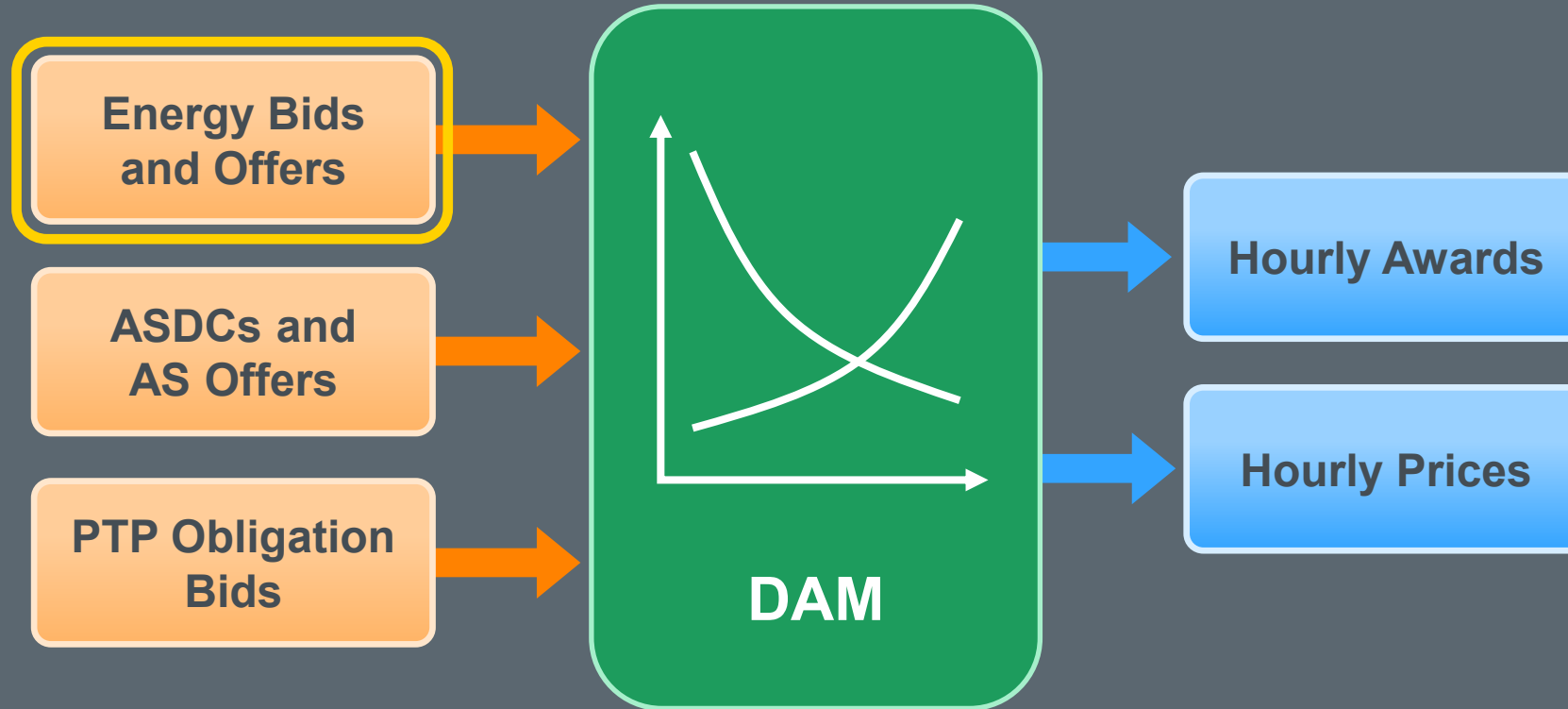

## Solution must represent allowable power flow

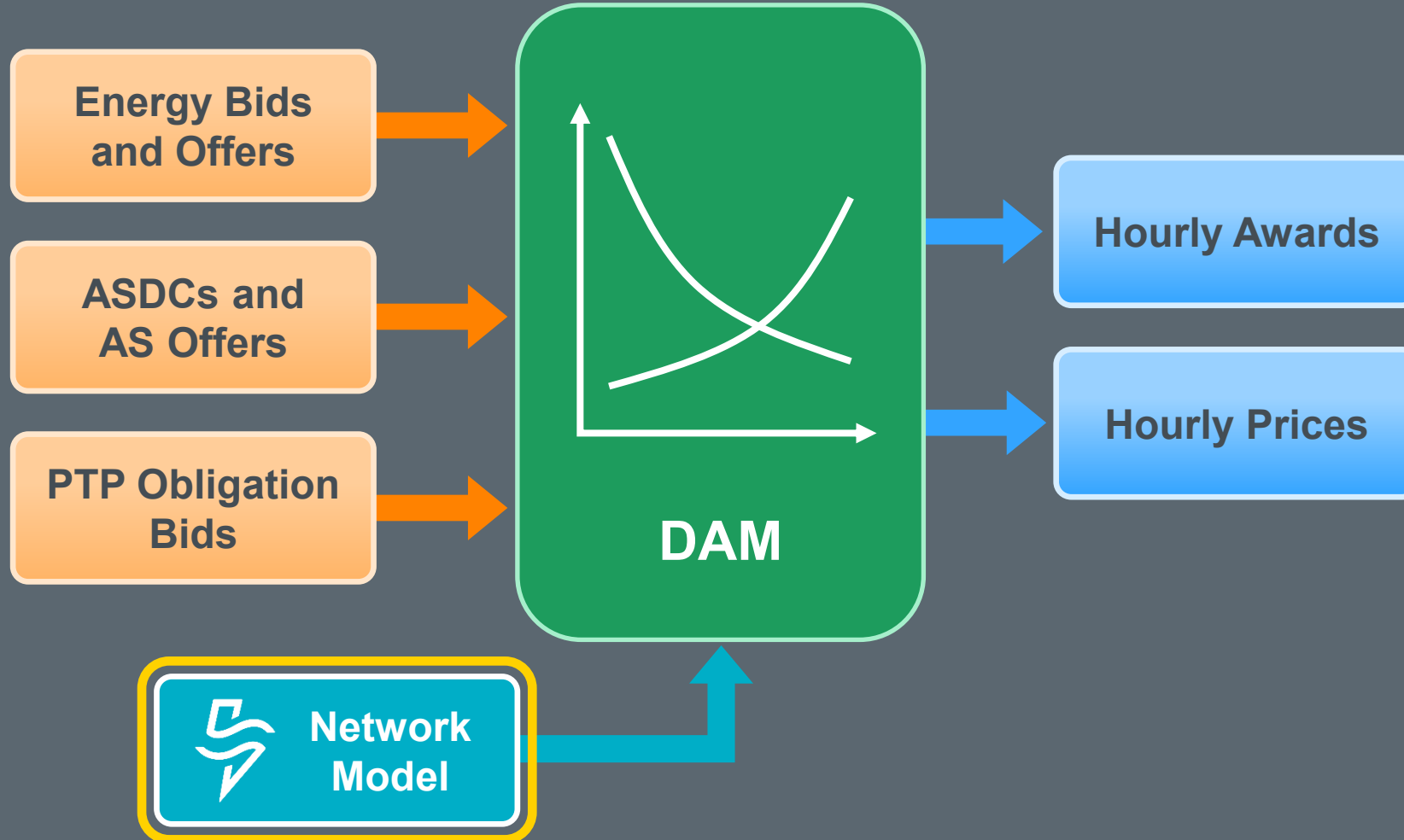



## Introducing a simple Network Model ...

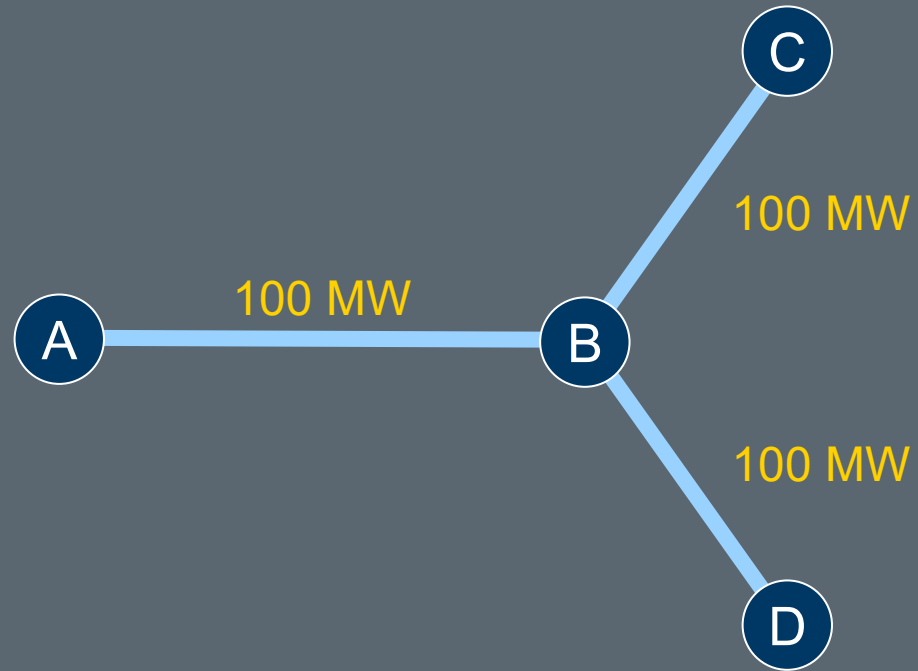

 = Settlement Point

MW = Transmission Capacity

## Energy Bids and Offers

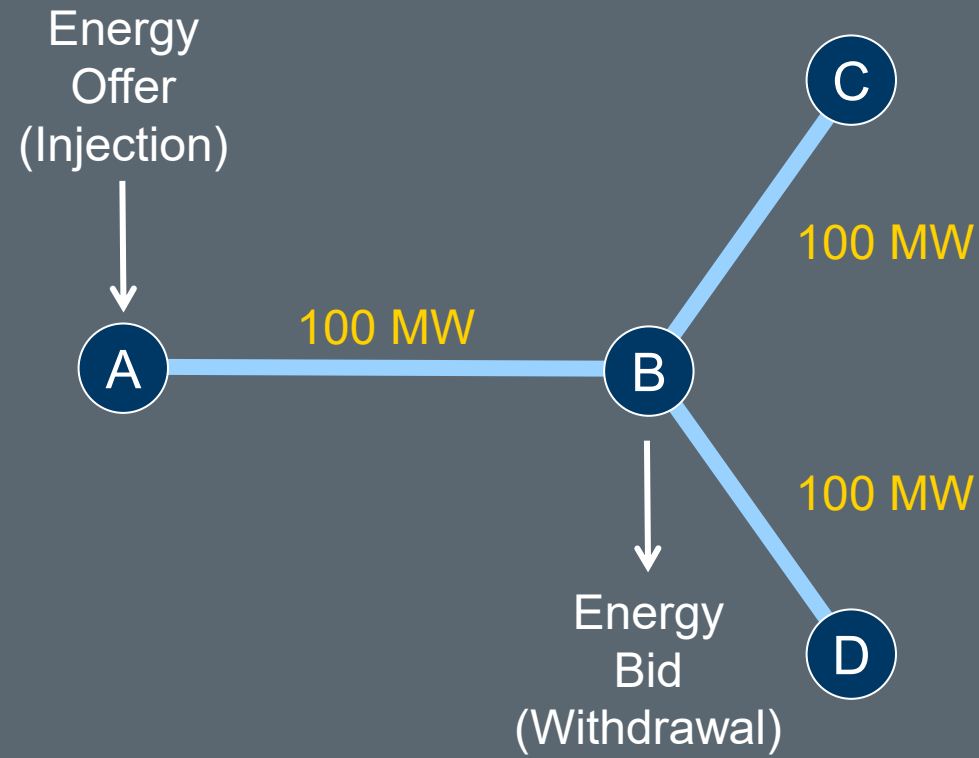

## PTP Obligations Bids

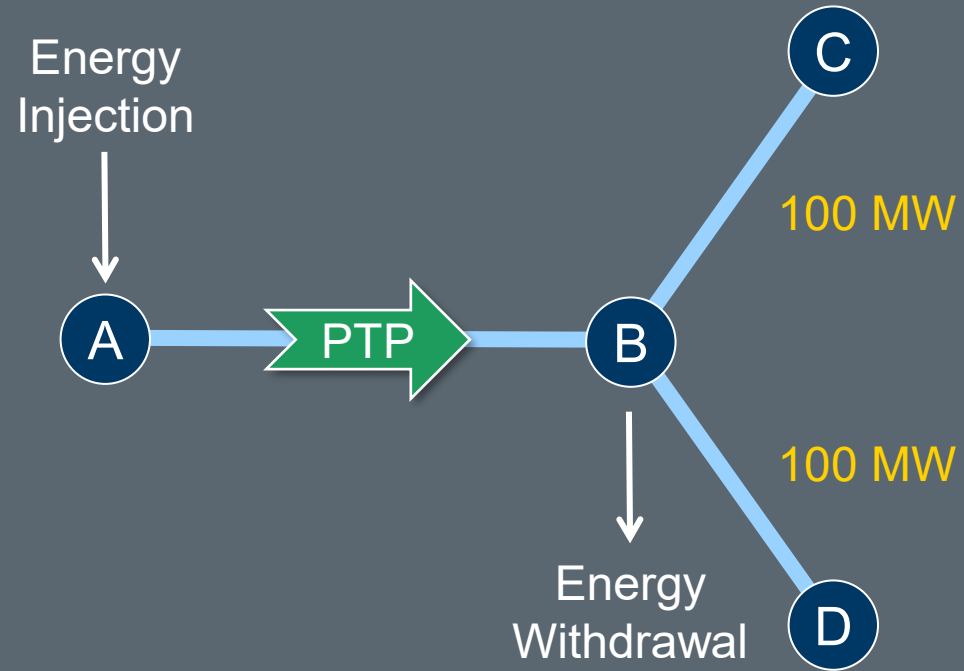

## Ancillary Service Offers and Demand Curves?

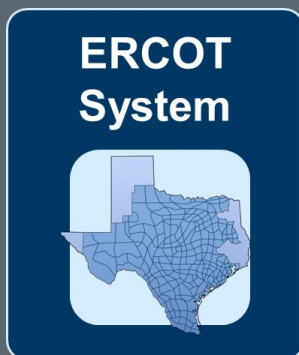
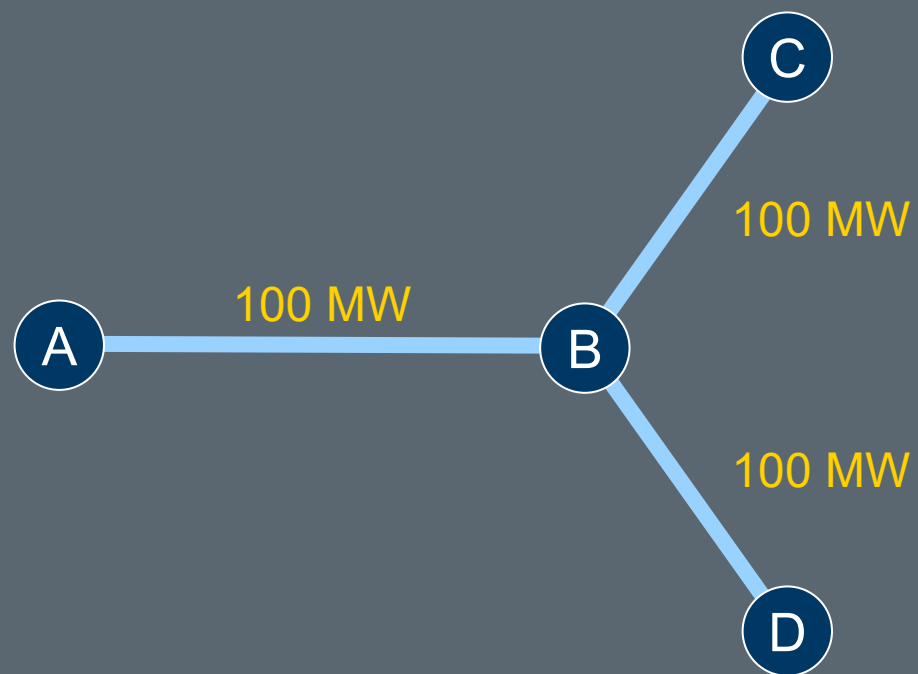



# Use RTC\_DAM Clearing Workbook

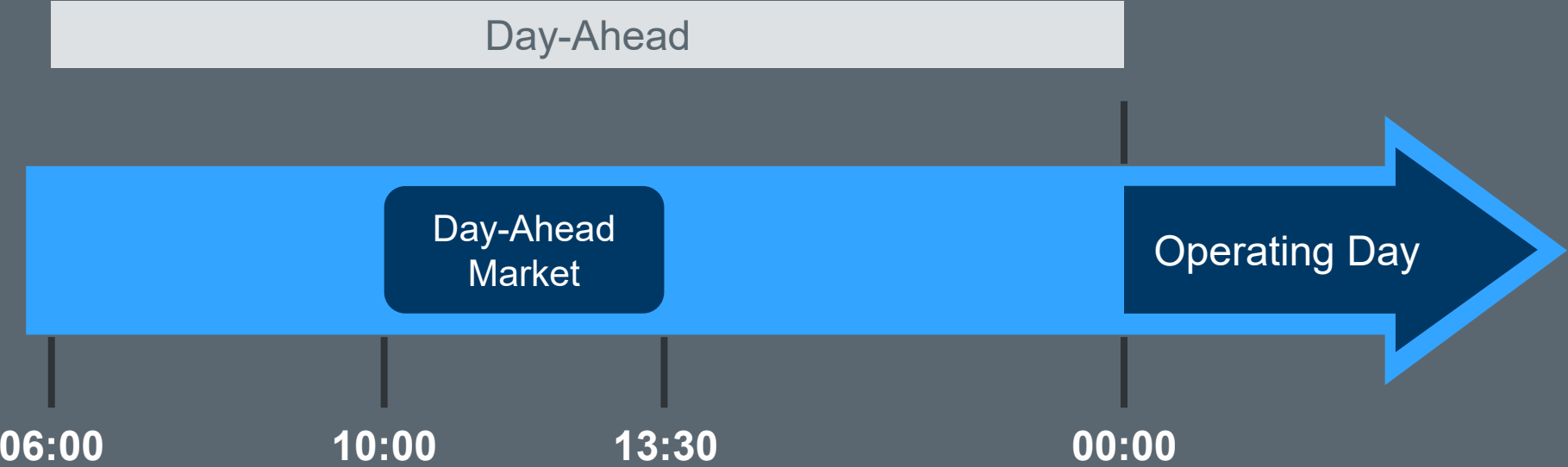

**ERCOT Posts Results  
by 13:30**

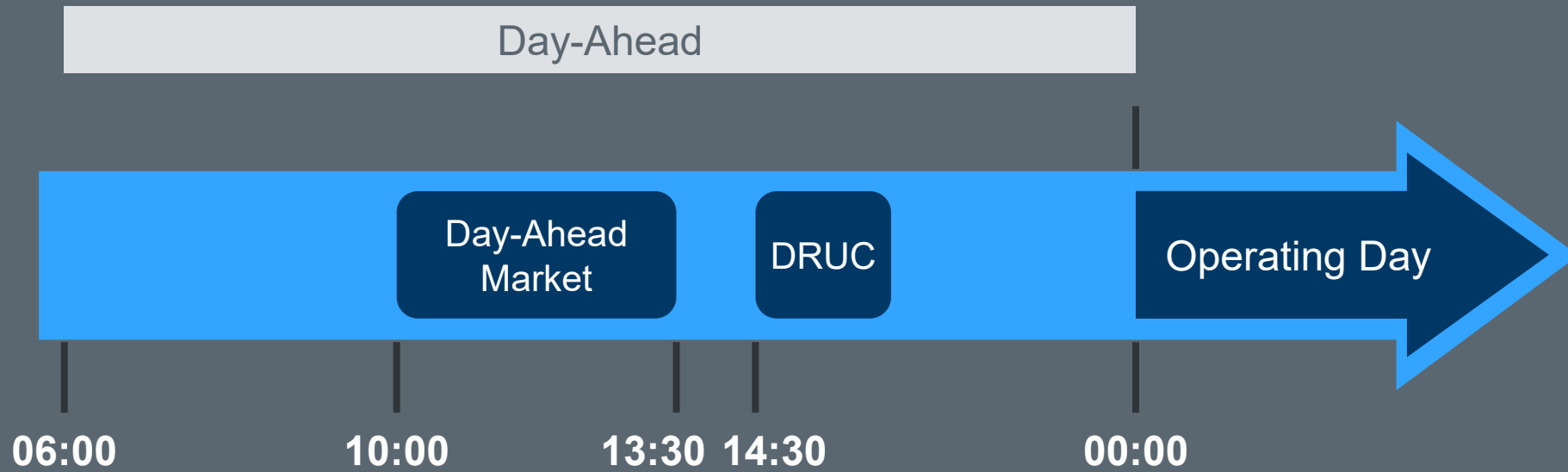

**QSE may need to act on DAM Results**

## Self-Arranged Ancillary Services

Self-Arranged AS Quantities

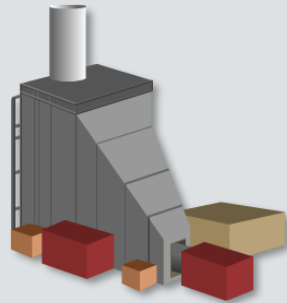

... must be arranged by 14:30

Current Operating Plan											
Resource Name	Resource Status	Resource Limits		ESR SOC Limits			Ancillary Service Capabilities				
		HSL	LSL	Min	Max	Hour Beginning	Reg-Up	Reg-Dn	Responsive	ECRS	NSRS
GEN1	ON	600	120	-	-	-	20	20	40	40	120
GEN2	OFF	100	25	-	-	-	0	0	0	0	0
ESR3	ON	40	-40	0	40	40	0	0	40	20	10



## A QSE has an awarded Energy or AS Offer in DAM



*What is required?*



# Day-Ahead Market Financial Impacts

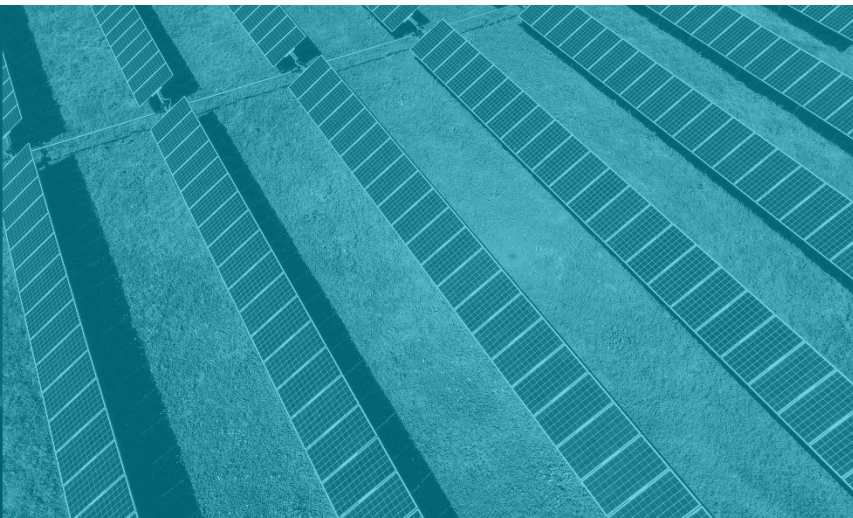

## ERCOT settles with QSEs

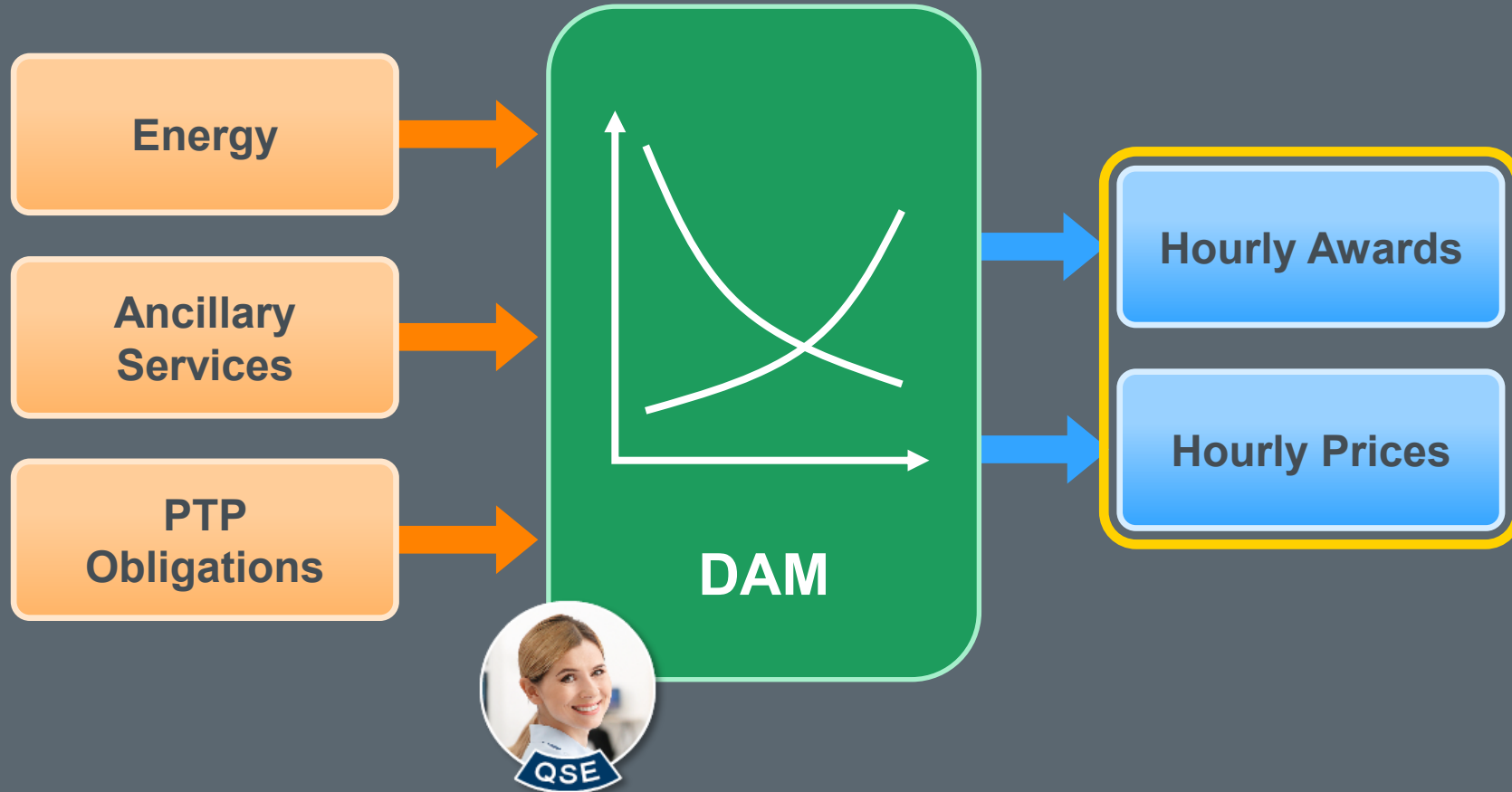

## Day-Ahead Settlement Point Prices (DASPPs)

**Resource Nodes**



**Load Zones**



**Hubs**

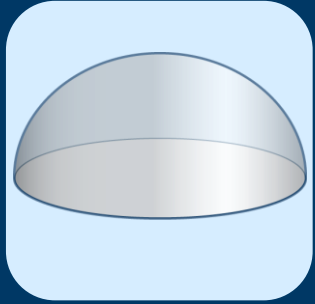

*Formed from Locational Marginal Prices*

## Market Clearing Prices for Capacity (MCPCs) \*

**MCPCR**U – Regulation-Up

**MCPCR**D – Regulation-Down

**MCPCR**R – Responsive Reserve

**MCPC**ECR – ERCOT Contingency Reserve

**MCPC**NS – Non-Spin Reserve

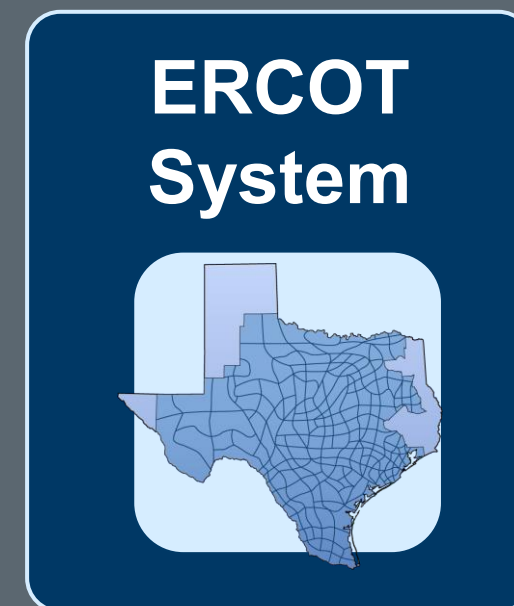

\* All MCPCs capped at VOLL



Payments for  
Ancillary Service  
Awards

Charges for  
Obligations not  
Self-Arranged



# Course Wrap-Up



Format	Title
WBT	Wholesale Markets Overview

Format	Title	Topic
ILT	Day-Ahead Market Operations	Inputs
		Market Clearing
		Financial Impacts
	Reliability Unit Commitment	Overview
		Process
		Financial Impacts
	Real-Time Market Operations	Security Constrained Economic Dispatch
		Load Frequency Control
		Financial Impacts

## **ERCOT Training Information**

<http://www.ercot.com/services/training/>

## **Course Recommendations**

<https://www.ercot.com/services/training/recommendations>

## **Market Education Contact**

[Training@ercot.com](mailto:Training@ercot.com)

## **ERCOT Client Services Contact**

[Clientservices@ercot.com](mailto:Clientservices@ercot.com)

## **ERCOT Mailing Lists**

<http://lists.ercot.com/>

***Scan this QR code to take the course survey!***

<https://www.surveymonkey.com/r/ERCOTILT>

