

# NERC

NORTH AMERICAN ELECTRIC  
RELIABILITY CORPORATION

# Data Center Event

## Recent Large Load Loss Event

Rich Bauer  
ERCOT LFLTF  
March 2025

**RELIABILITY | RESILIENCE | SECURITY**



## Incident Review

### Considering Simultaneous Voltage-Sensitive Load Reductions

#### Primary Takeaways

Operators and planners of the Bulk Electric System (BES) should be aware of the risks and challenges associated with voltage-sensitive large loads that are rapidly being connected to the power system. Specifically, when considering data centers and cryptocurrency mining facilities, entities should be aware of the potential for large amounts of voltage-sensitive load loss during normally cleared faults on the BES. Voltage-sensitive data center-type loads have increased on the system and are predicted to continue growing rapidly. The 2024 NERC *Long-Term Reliability Assessment* (LTRA) documents and discusses this potential growth of data center-type loads. This vignette highlights this load-loss potential based on analysis of a recent event in the Eastern Interconnection and offers some considerations for BES operators, planners, and regulators concerning identifying and mitigating the potential reliability effects and risks presented by these large voltage-sensitive load losses for future operations.

#### Summary of Incident

A 230 kV transmission line fault led to customer-initiated simultaneous loss of approximately 1,500 MW of voltage-sensitive load that was not anticipated by the BES operators. The electric grid has not historically experienced simultaneous load losses of this magnitude in response to a fault on the system, which has historically been planned for large generation losses but not for such significant simultaneous load losses. Simultaneous large load losses have two effects on the electric system: First, frequency rises on the system as a result of the imbalance between load and generation; second, voltage rises rapidly because less power is flowing through the system. In this incident, the frequency did not rise to a level high enough to cause concern. The voltage also did not rise to levels that posed a reliability risk, but operators did have to take action to reduce the voltage to within normal operating levels. However, as the potential for this type of load loss increases, the risk for frequency and voltage issues also increases. Operators and planners should be aware of this reliability risk and ensure that these load losses do not reach intolerable levels.

#### Incident Details

At approximately 7:00 p.m. Eastern on July 10, 2024, a lightning arrester failed on a 230 kV transmission line in the Eastern Interconnection, resulting in a permanent fault that eventually "locked out" the transmission line. The auto-reclosing control on the transmission line was configured for three auto-reclose attempts staggered at each end of the line. This configuration resulted in 6 successive system faults in an 82-second period. The protection system detected these faults and cleared them properly. The shortest fault duration was the initial fault at 42 milliseconds, and the longest fault duration was 66 milliseconds. The voltage magnitudes during the fault ranged from .25 to .40 per unit in the load-loss area.

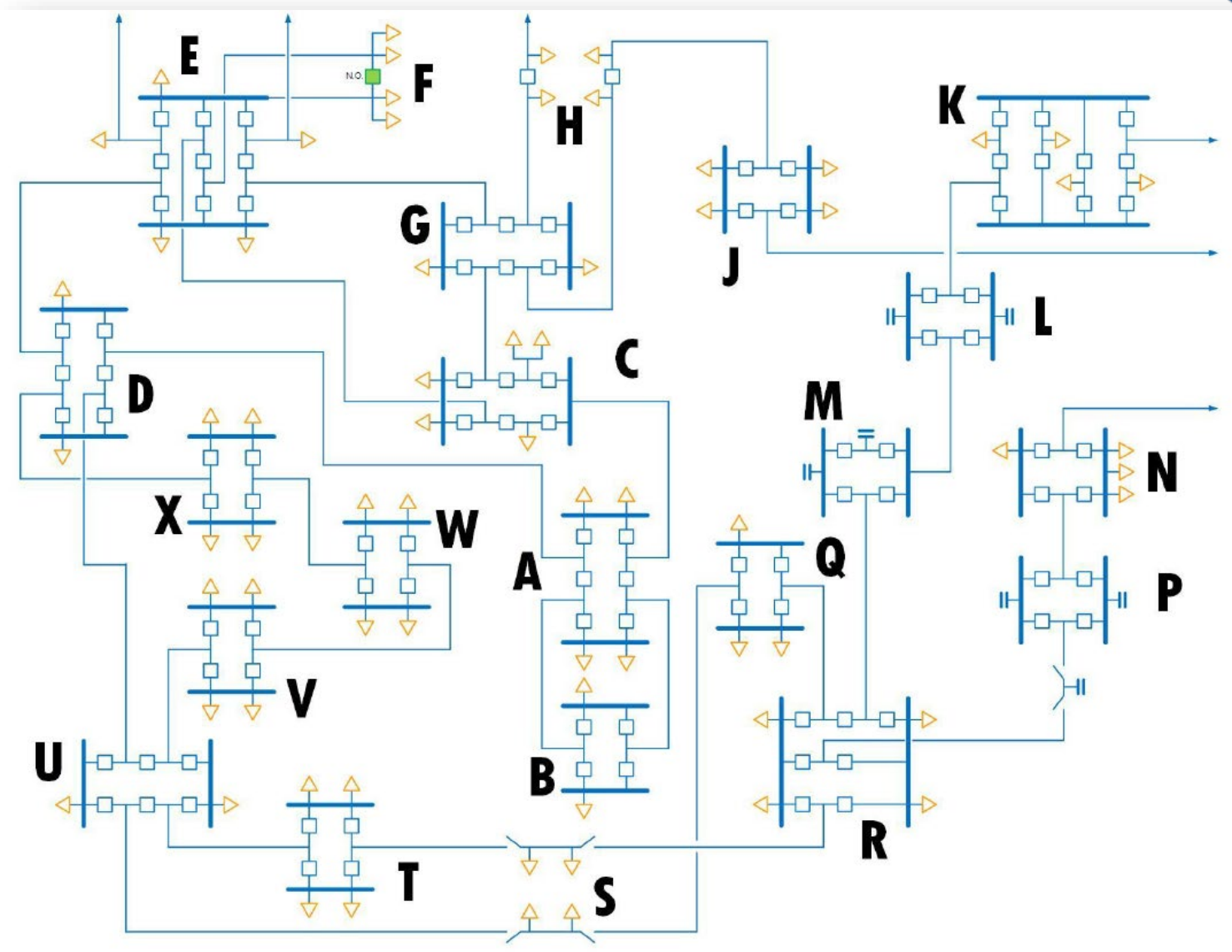

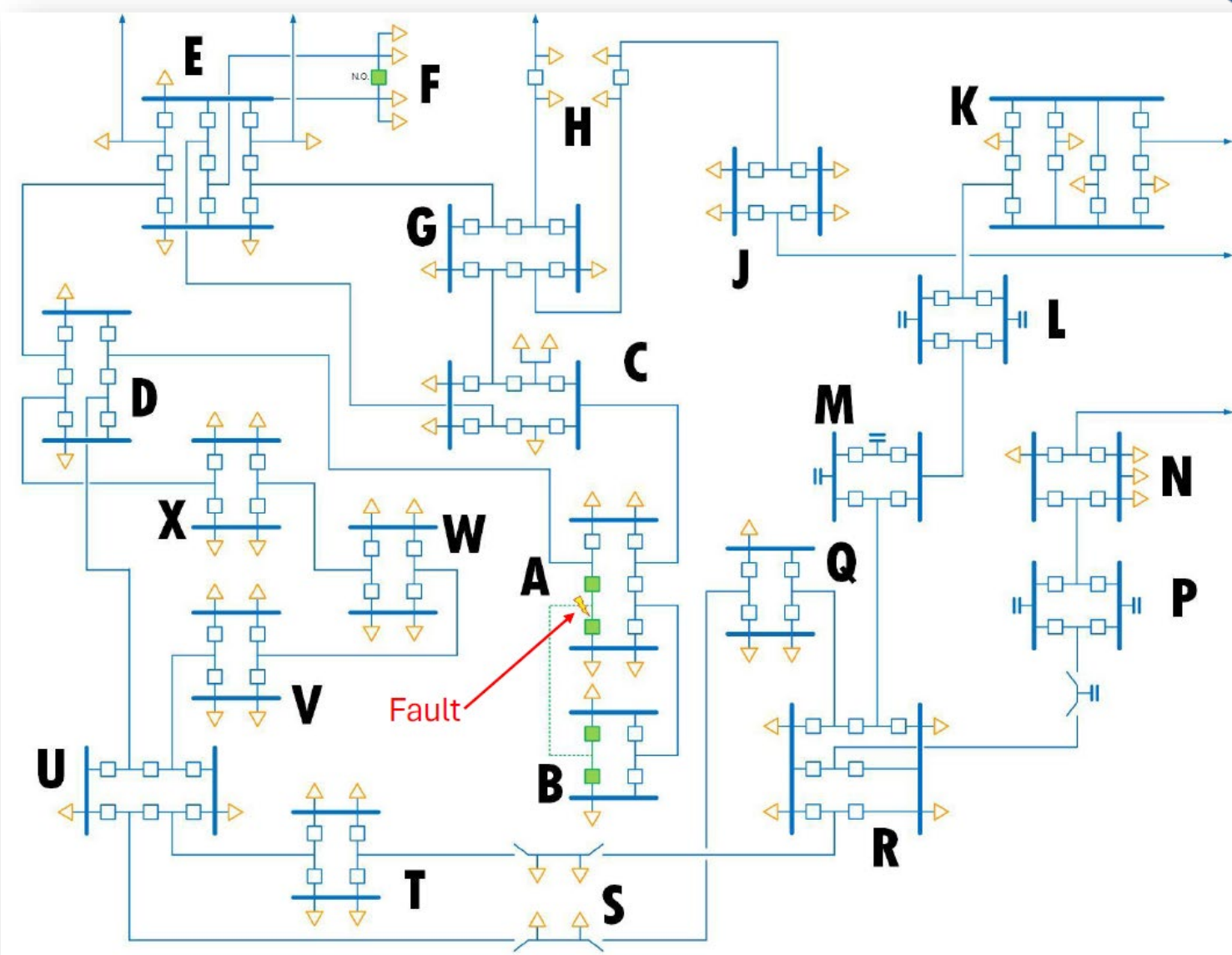

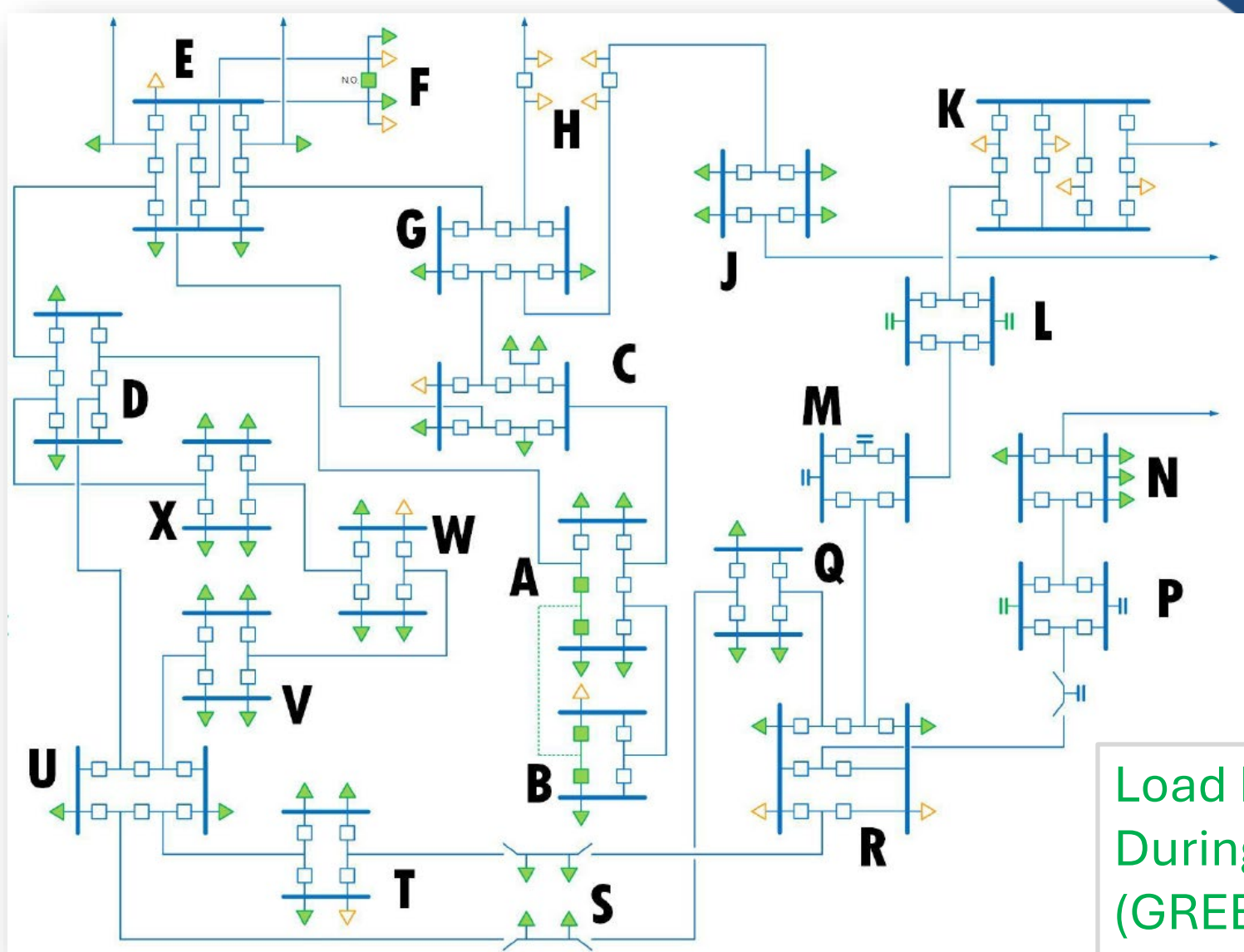

Load Lost  
During Event  
(GREEN)

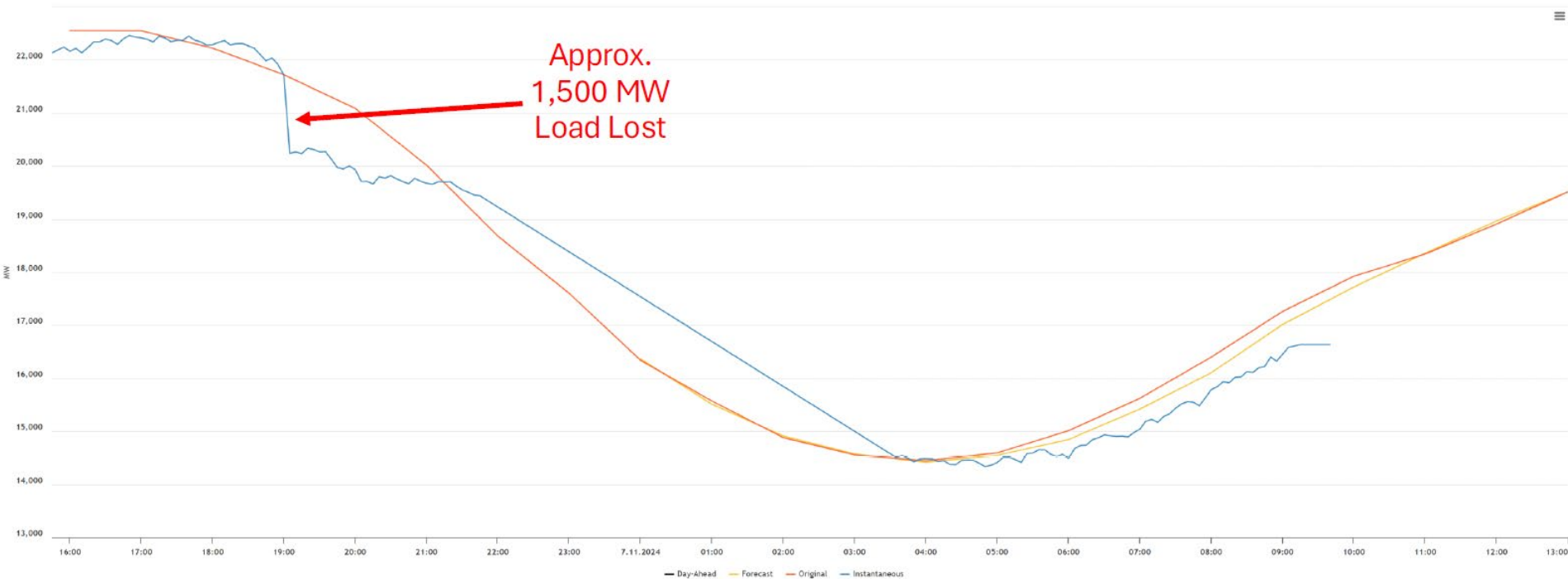

- Exclusively Data Center load
- 25-30 substations
- ~ 60 individual data center load points
- Individual load loss ranged from 2 MW to 85 MW

Data Center Load Transferred

Station	TX	MVA	Customer	Station	TX	MVA	Customer	Station	DP	MVA	Customer
	1	10		4	10				1	50	
	2	20		2	22				2	10	
	3	20		3	20				1	45	
	4	20		4	10				1	82	
	6	15		2	2				1	55	
	1	25		4	10				2	42	
	2	10		1	30						
	3	60		2	40						
	5	40		3	40						
	2	2		4	30						
	3	2		1	72						
	1	2		2	95						
	2	2		1	72						
	3	2		2	55						
	4	20		3	32						
	1	60		6	27						
	2	55		2	15						
	3	75		3	10						
	4	45		3	35						
	3	10		4	35						
	4	2		1	5						
	5	5		2	10						
	1	5		3	15						
	3	13		4	15						
	4	2									
	3	8									
	1	2									
	2	5									
	3	3									
	4	20									

DEV SUBTOTAL = 1,267  
 COOP SUBTOTAL = 284  
**TOTAL LOAD = 1,551**

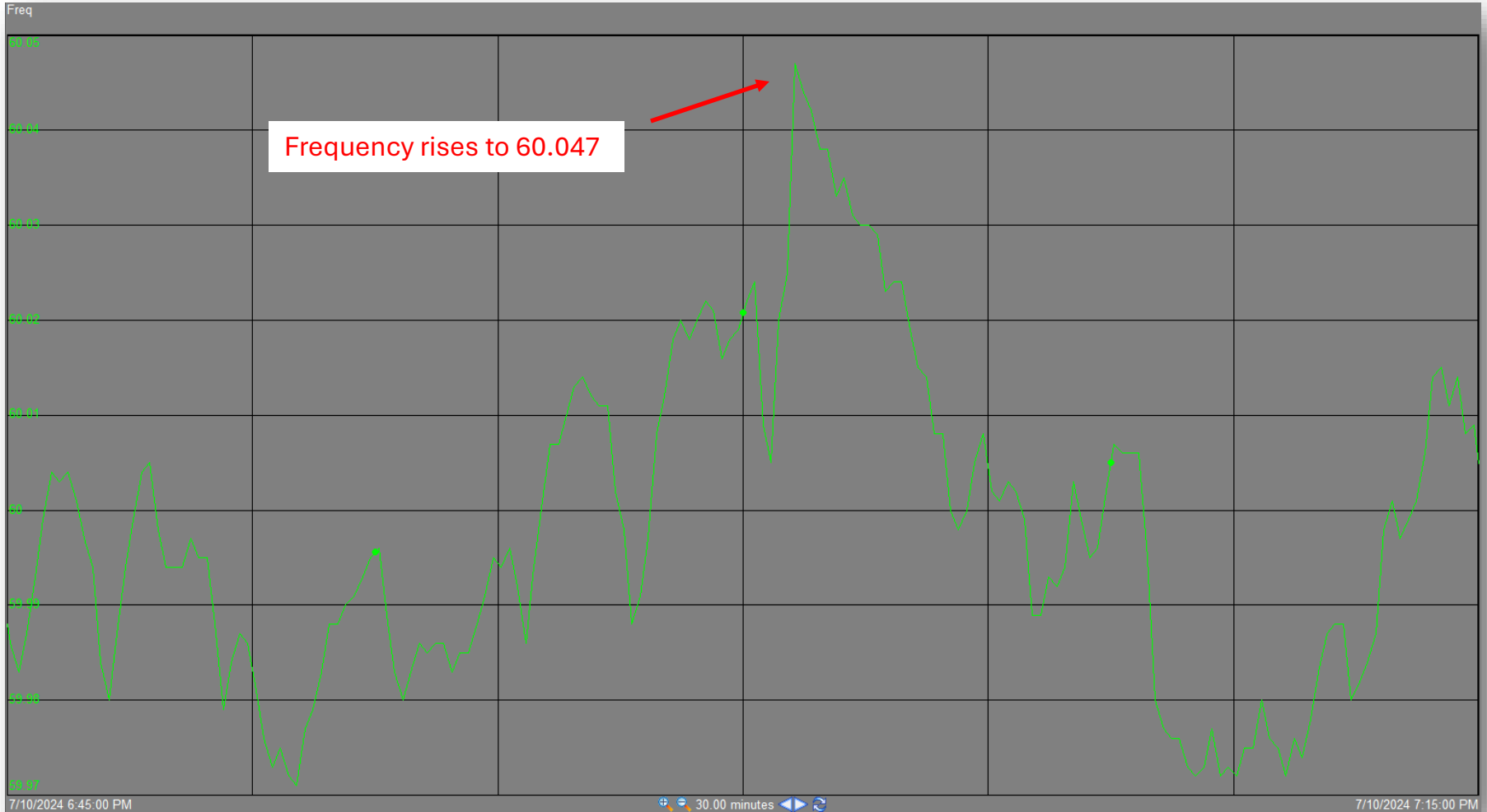

- High Voltage
- Less than 1.1 per unit
- Operators removed local area 230 kV capacitor banks to reduce voltage

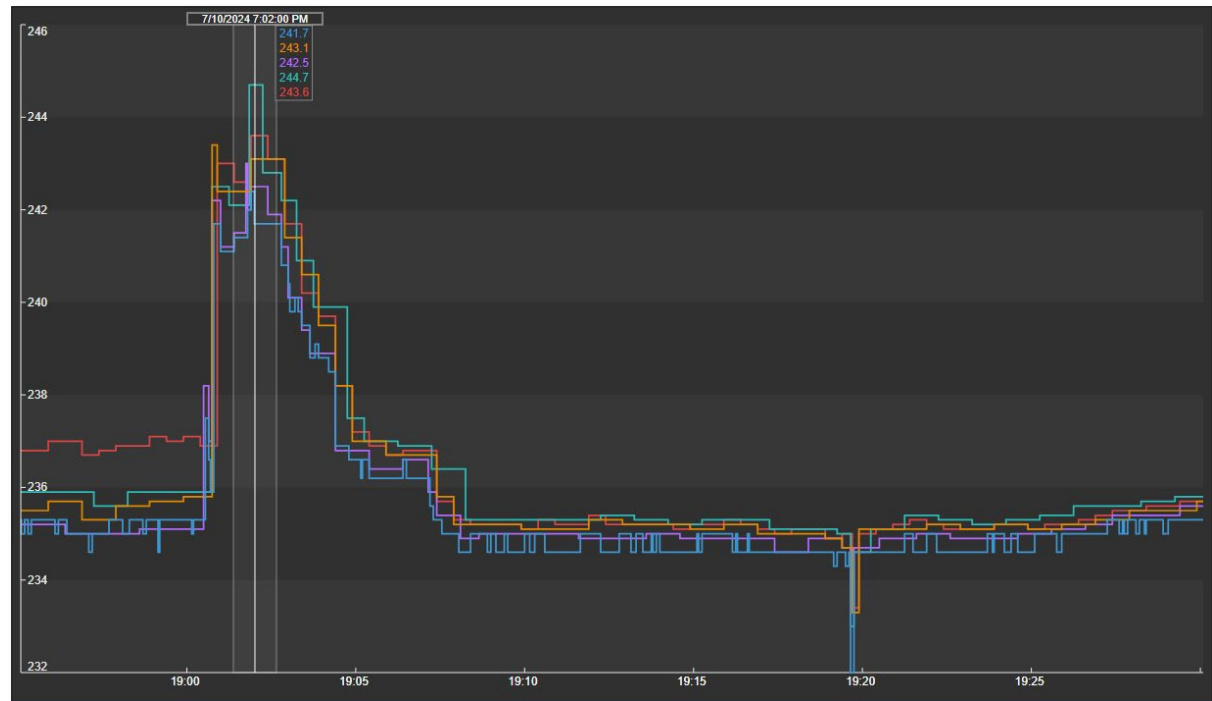

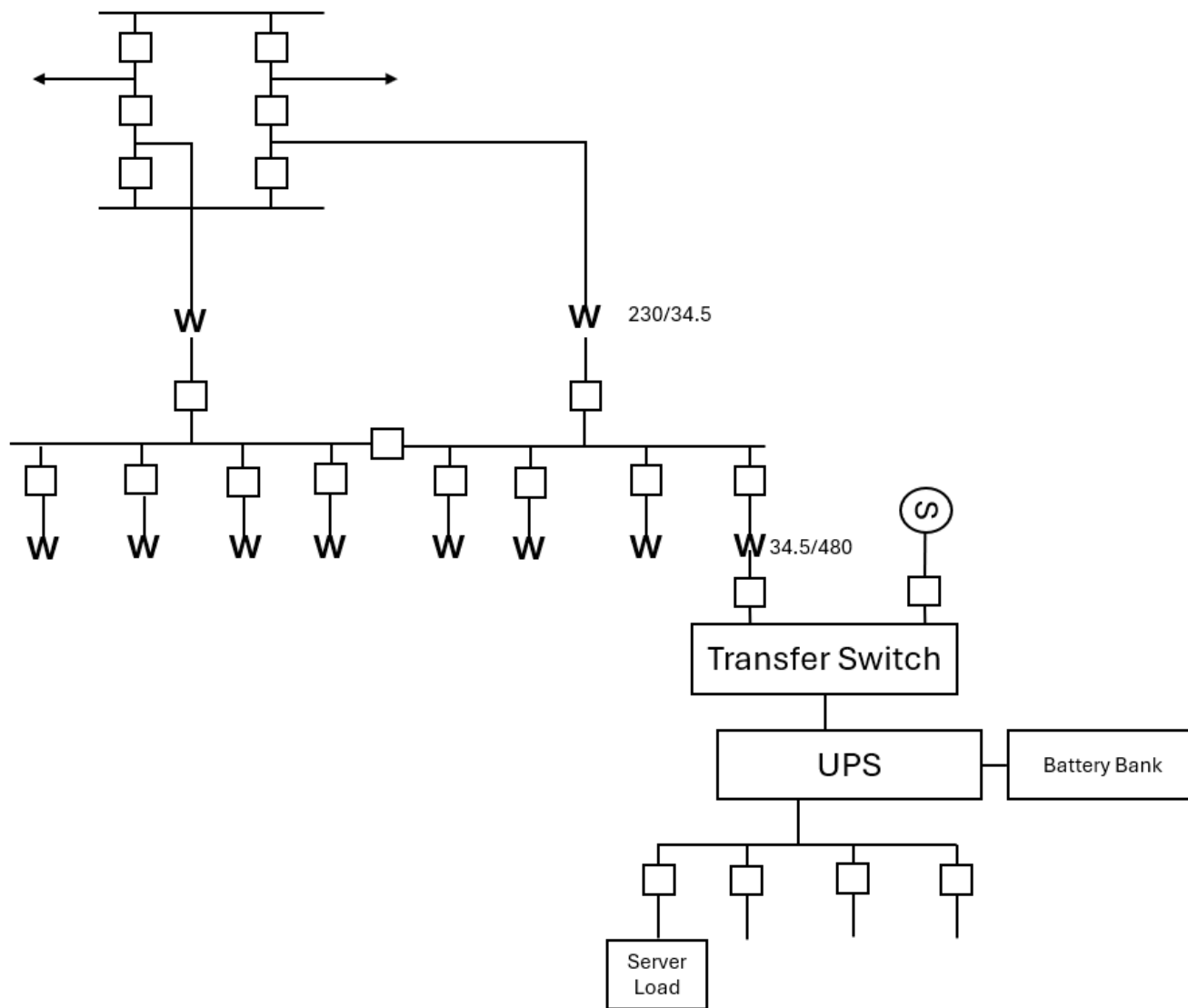

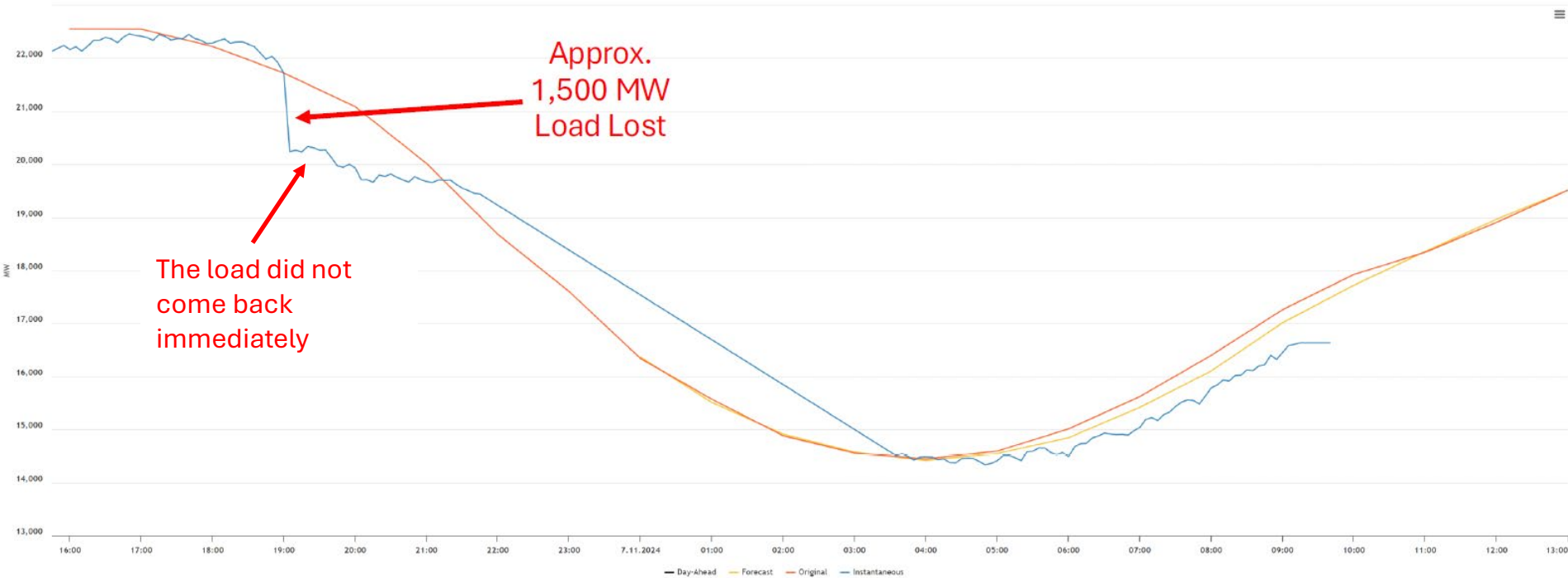

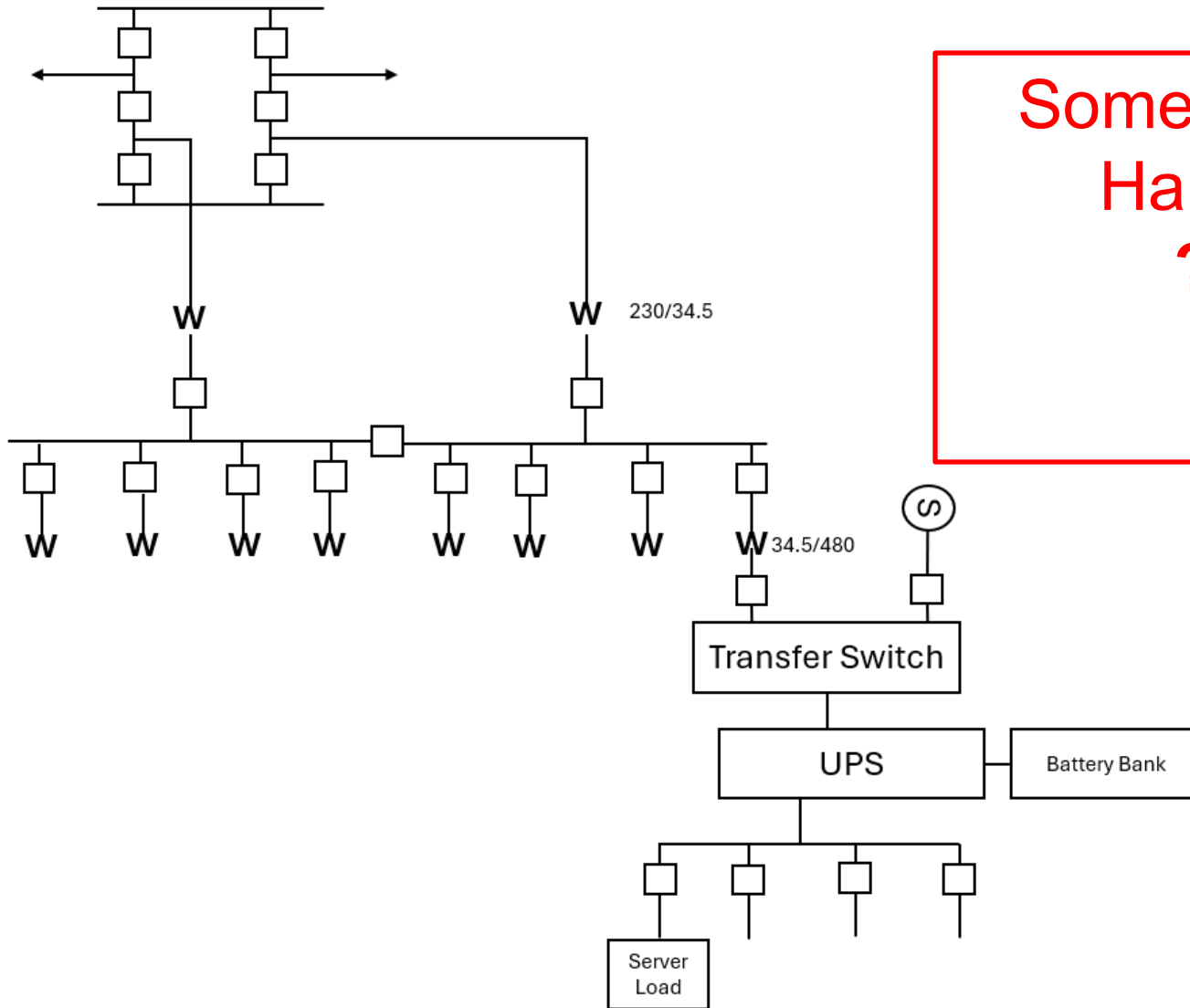

Something Else  
Happened  
????

- Call with Data Center Coalition (DCC)
  - Cooling load is critical after voltage disturbance
  - Design follows ITIC curve
  - Will “lockout” after a number of events in a specific period of time
  - More than one power distribution architecture

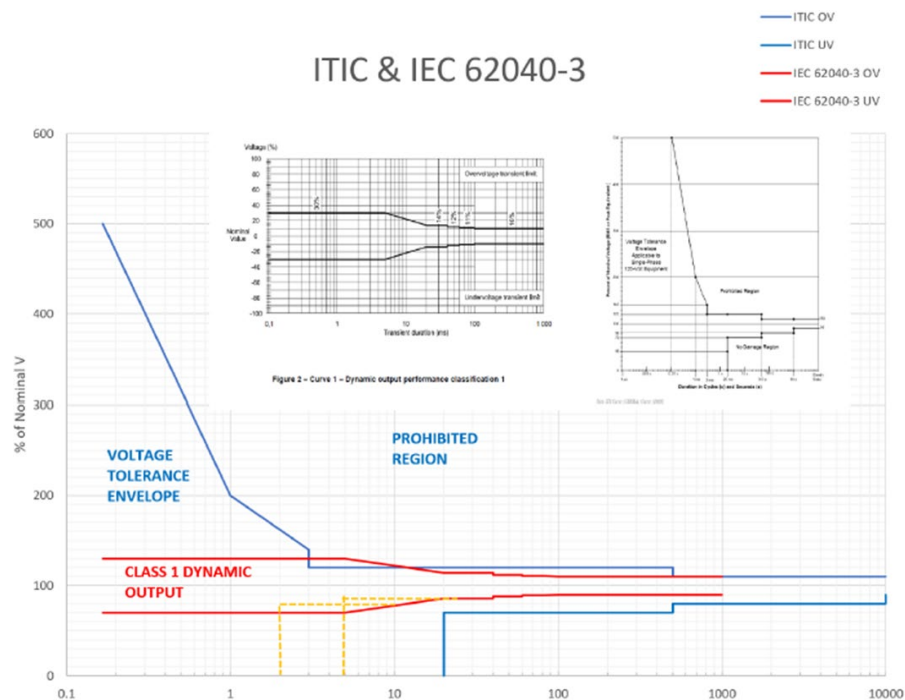

- Call with Data Center Coalition (DCC)
  - Cooling load is critical after voltage disturbance
  - Design follows ITIC curve
  - Will “lockout” after a number of events in a specific period of time
  - More than one power distribution architecture

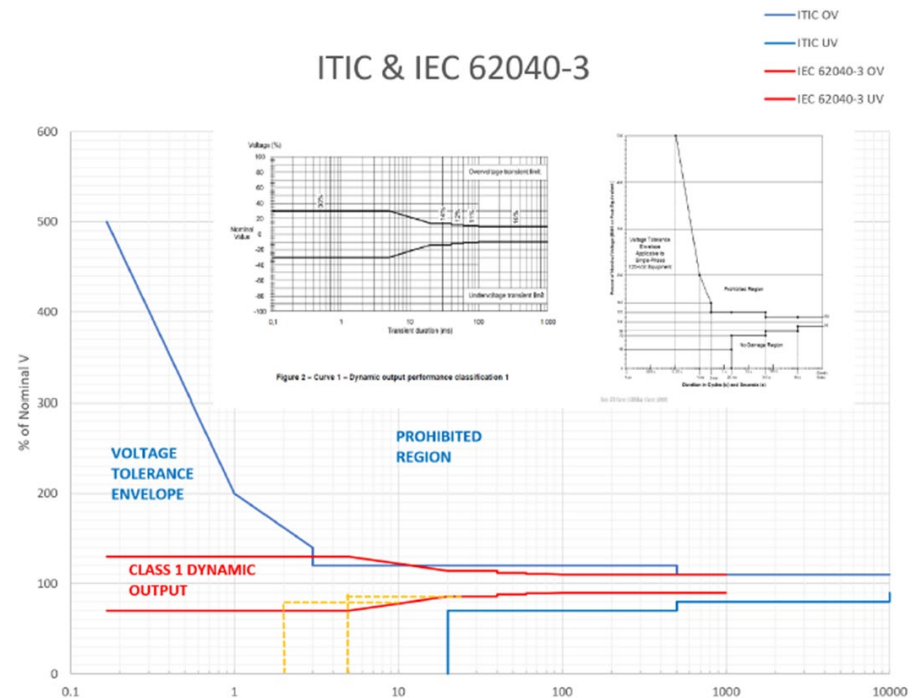

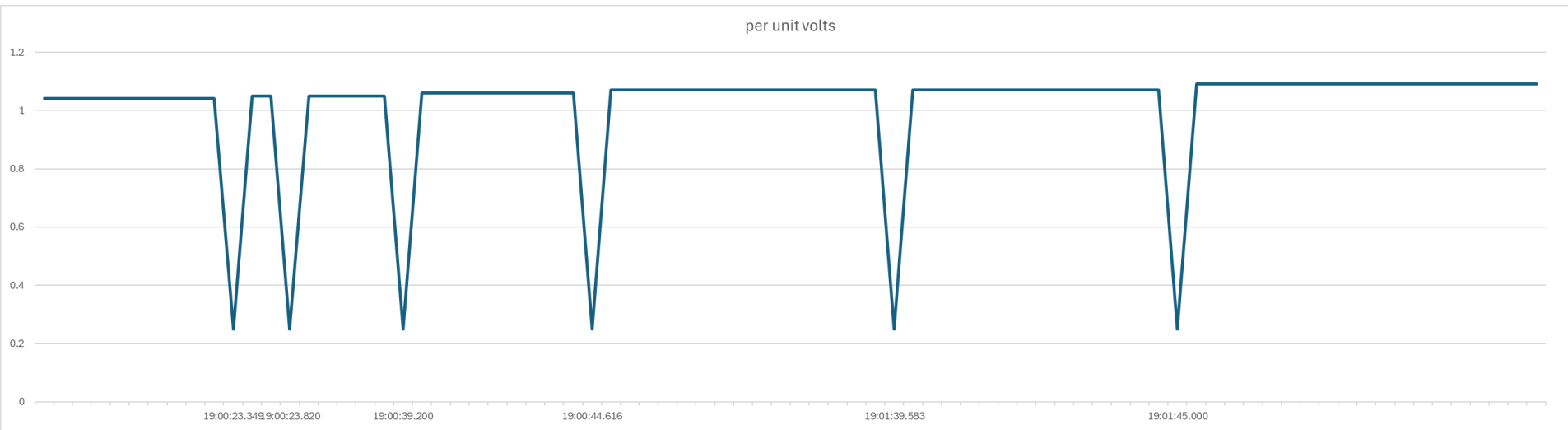

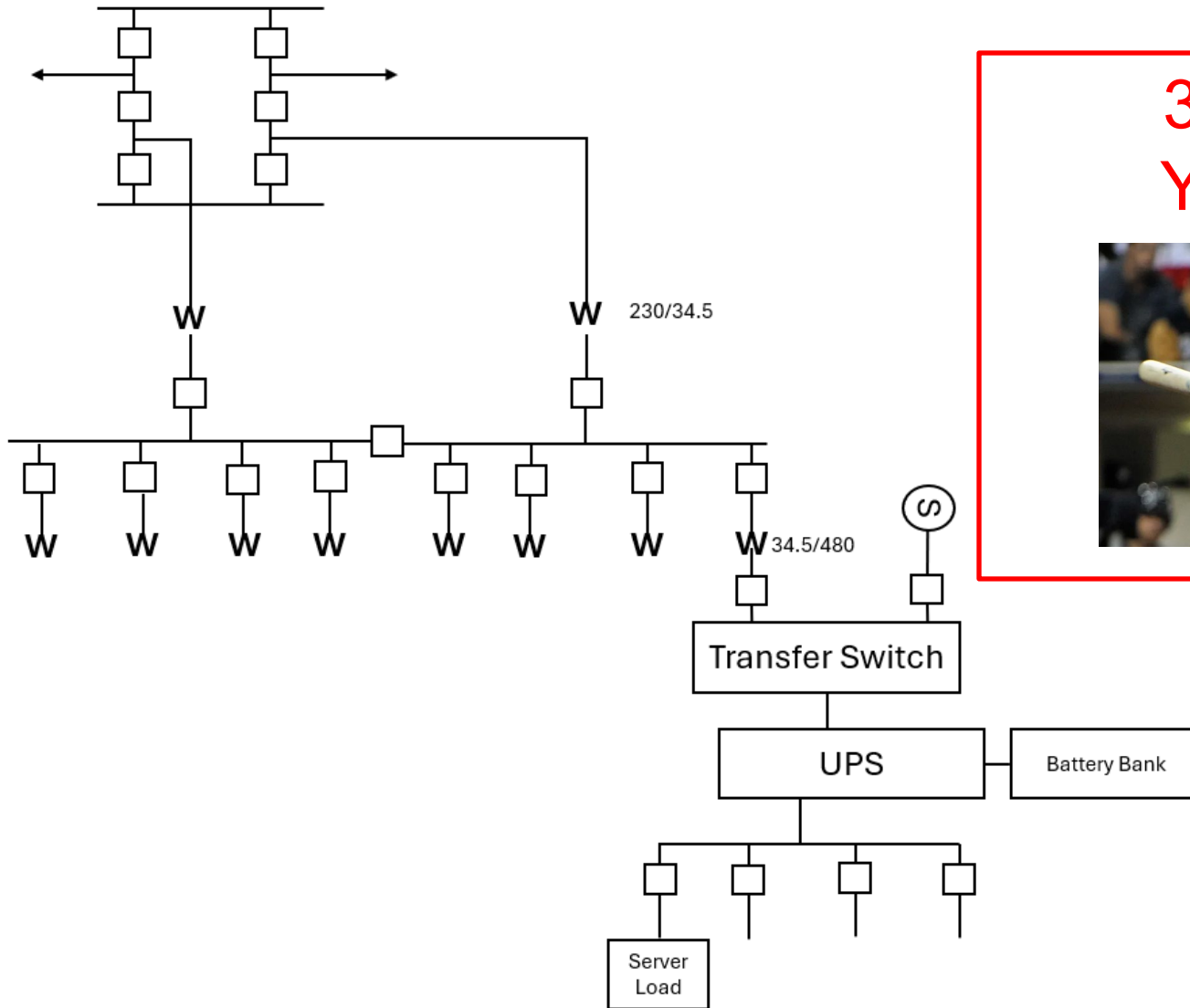

**3 Strikes...  
You're Out!**



- *“The demand for data centers is currently exploding, with Goldman Sachs projecting a 160% increase in demand by 2030. AI is a huge part of that. A ChatGPT inquiry requires almost 10 times as much electricity as a Google one.”*

- Require dynamic response models of large loads in facility interconnection requirements
- Perform studies to determine the potential magnitude of load loss for system disturbances (faults)
- Take into consideration the potential for voltage-sensitive load loss when configuring automatic reclosing schemes

**NERC**  
NORTH AMERICAN ELECTRIC  
RELIABILITY CORPORATION

## Incident Review

### Considering Simultaneous Voltage-Sensitive Load Reductions

**Primary Takeaways**  
Operators and planners of the Bulk Electric System (BES) should be aware of the risks and challenges associated with voltage-sensitive large loads that are rapidly being connected to the power system. Specifically, when considering data centers and cryptocurrency mining facilities, entities should be aware of the potential for large amounts of voltage-sensitive load loss during normally cleared faults on the BES. Voltage-sensitive data center-type loads have increased on the system and are predicted to continue growing rapidly. The 2024 NERC *Long-Term Reliability Assessment (LTRA)* documents and discusses this potential growth of data center-type loads. This vignette highlights this load-loss potential based on analysis of a recent event in the Eastern Interconnection and offers some considerations for BES operators, planners, and regulators concerning identifying and mitigating the potential reliability effects and risks presented by these large voltage-sensitive load losses for future operations.

**Summary of Incident**  
A 230 kV transmission line fault led to customer-initiated simultaneous loss of approximately 1,500 MW of voltage-sensitive load that was not anticipated by the BES operators. The electric grid has not historically experienced simultaneous load losses of this magnitude in response to a fault on the system, which has historically been planned for large generation losses but not for such significant simultaneous load losses. Simultaneous large load losses have two effects on the electric system: First, frequency rises on the system as a result of the imbalance between load and generation; second, voltage rises rapidly because less power is flowing through the system. In this incident, the frequency did not rise to a level high enough to cause concern. The voltage also did not rise to levels that posed a reliability risk, but operators did have to take action to reduce the voltage to within normal operating levels. However, as the potential for this type of load loss increases, the risk for frequency and voltage issues also increases. Operators and planners should be aware of this reliability risk and ensure that these load losses do not reach intolerable levels.

**Incident Details**  
At approximately 7:00 p.m. Eastern on July 10, 2024, a lightning arrester failed on a 230 kV transmission line in the Eastern Interconnection, resulting in a permanent fault that eventually “locked out” the transmission line. The auto-reclosing control on the transmission line was configured for three auto-reclose attempts staggered at each end of the line. This configuration resulted in 6 successive system faults in an 82-second period. The protection system detected these faults and cleared them properly. The shortest fault duration was the initial fault at 42 milliseconds, and the longest fault duration was 66 milliseconds. The voltage magnitudes during the fault ranged from .25 to .40 per unit in the load-loss area.

RELIABILITY | RESILIENCE | SECURITY

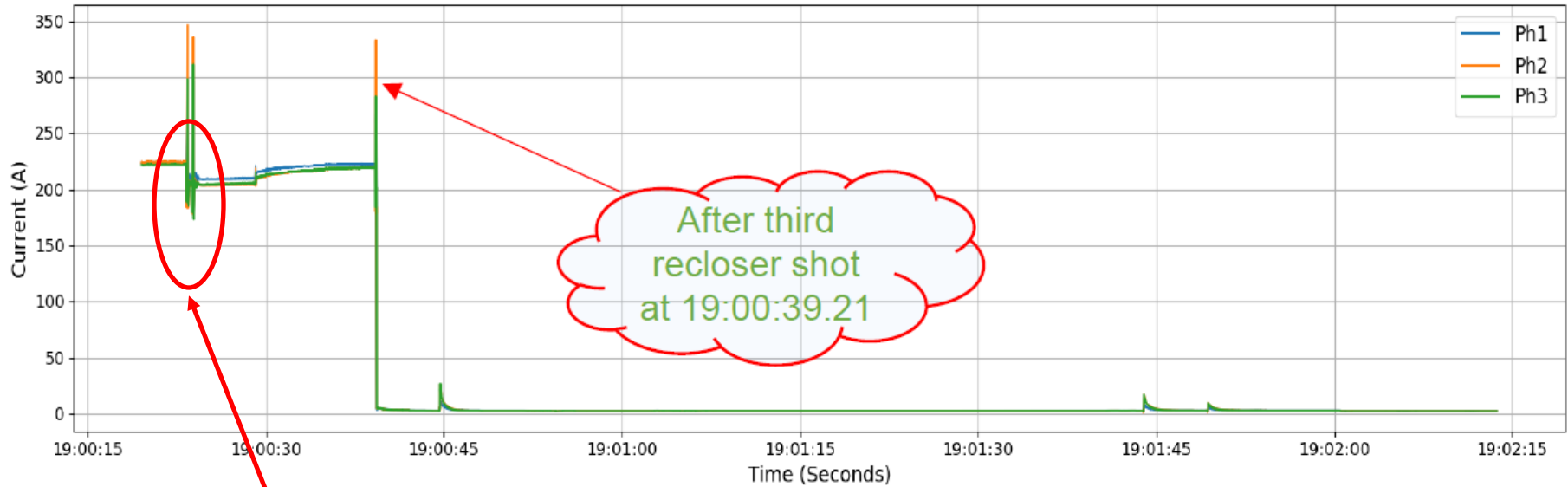

We need to understand exactly what this ride through response looks like for all facilities

A map of North America is shown with three distinct color regions: a light purple region in the north, a dark blue region in the center, and a hatched region in the south. The word "Questions" is written in large, bold, black font across the center of the map, overlapping the dark blue region.

# Questions