



ERCOT Market Education

Intermittent Renewable Resources



2024_07 IRR

Protocol Disclaimer

This presentation provides a general overview of the Texas Nodal Market and is not intended to be a substitute for the ERCOT Protocols, as amended from time to time. If any conflict exists between this presentation and the ERCOT Protocols, the ERCOT Protocols shall control in all respects.

For more information, please visit:

<http://www.ercot.com/mktrules/nprotocols/>

WebEx Training Tips

- Windows
- Buttons

Attendance

Questions / Chat

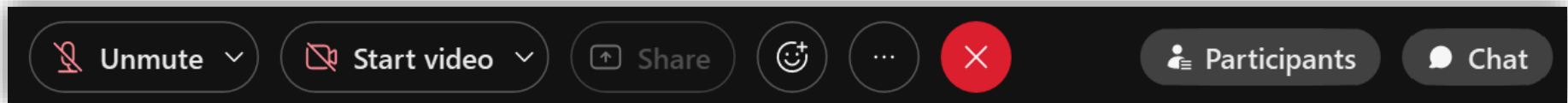

Modules in this course include:

1

IRR Definitions

2

Market Provisions and Requirements for IRRs

3

IRR Forecasting

4

IRR in Market and System Operations

5

Financial Settlements of IRRs

Module 1

IRR Definitions

Intermittent Renewable Resource (IRR) – A Generation Resource that can only produce energy from variable, uncontrollable Resources, such as wind, solar, or run-of-the-river hydroelectricity.

Currently, two types:

- Wind-Powered Generation Resource (WGR)
- PhotoVoltaic Generation Resource (PVGR)

Typically, WGRs and PVGRs are aggregations of Wind Turbines or Photovoltaic equipment

A Resource Entity may aggregate Intermittent Renewable Resource generation equipment together to form a single IRR.

General Rules:

- Same Electrical Bus
- Generally, same model and size¹
- Does not reduce ERCOT's ability to model



¹ See Protocol 3.10.7.2 (11) for exceptions

IRR Group – A group of two or more IRRs whose performance in responding to Security-Constrained Economic Dispatch (SCED) Dispatch Instructions will be assessed as an aggregate

- All IRRs must have the same Resource Node
- No Split Generation Resources

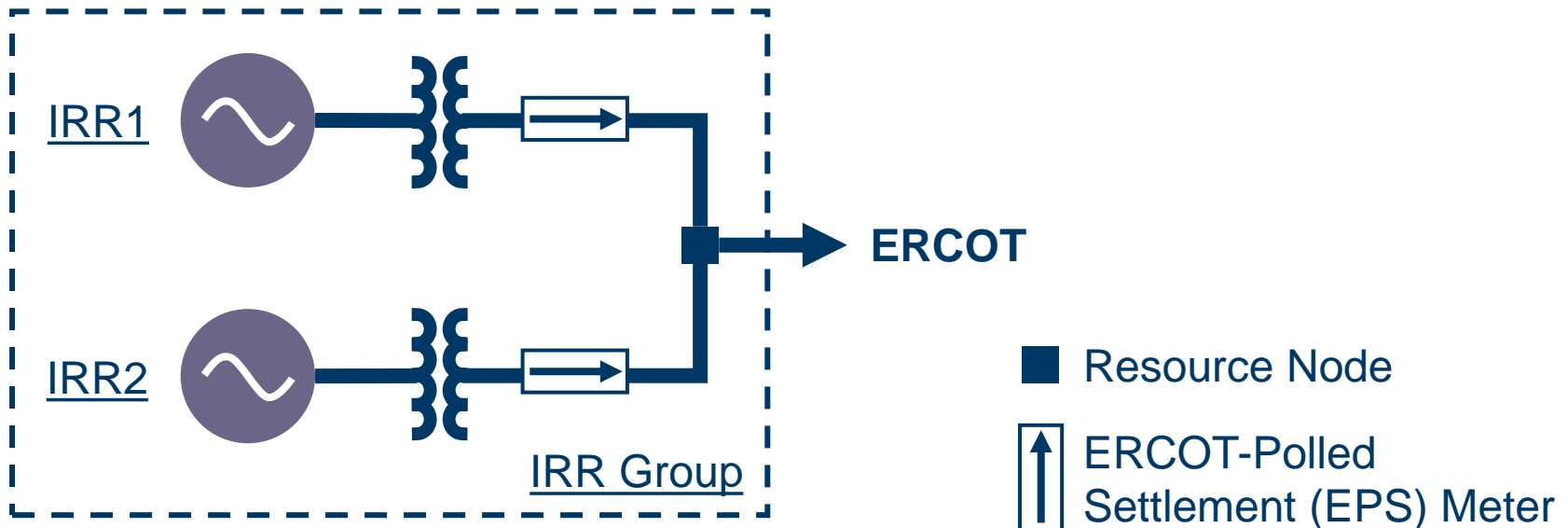

Discussion

A Resource Entity wants to build a single generation site with both wind generation and photovoltaic systems

1. *Can they create a single IRR?*
2. *Can they create an IRR Group?*



Module 2

**Market Provisions and Requirements
for IRRs**

Topics in this module ...

- What makes IRRs unique?
- Impacts to ERCOT
- General IRR operating requirements



Variability

Technology

Location



Variability

Intermittent Energy Supply

Capacity Uncertainty

Challenges

- Dispatchability
- Predictability

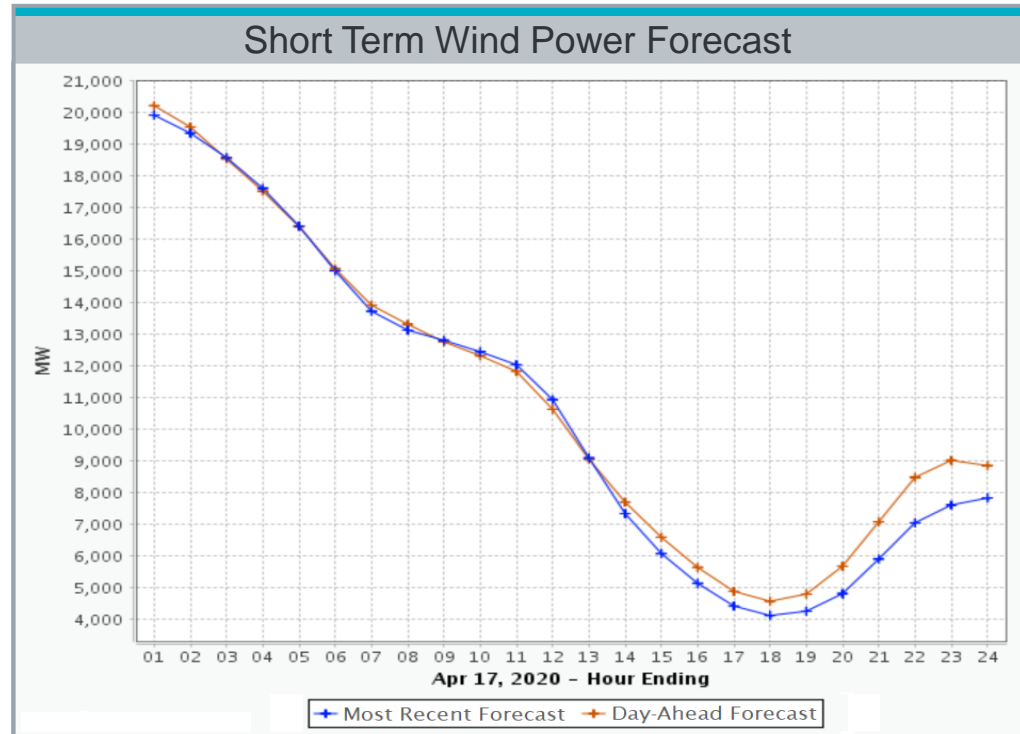

Intermittent
Energy Supply

Wind and Solar Energy – Use it or Lose it

- Non-IRRs chase their Base Points
- IRRs chase their energy supply
 - Run at max capability (unless curtailed)
 - Base Point is permissive



Capacity
Uncertainty

Centralized IRR Forecasting

- ERCOT responsible for IRR forecasting
- Consistent methodology for all IRRs

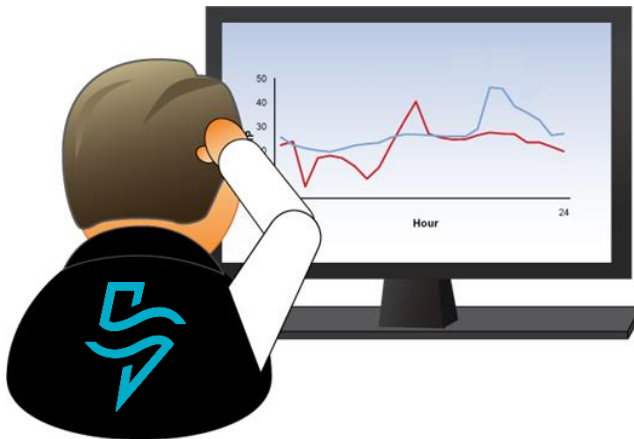

More details on forecasting
later in the course

Capacity Uncertainty

More telemetry data for IRRs means better forecasting

- Meteorological Tower Data from each site
- Detailed equipment status
 - Wind turbines in service
 - Inverters in service



	In-Service	Out	Unknown
Turbines	42	2	1
Inverters	28	1	1

Technology

Large Ramp Rates

Not Traditional Generators

Challenges

- Frequency control
- Voltage control



Large Ramp Rates

With nearly instantaneous ramp rates ...

Frequency could dip when IRRs curtailed

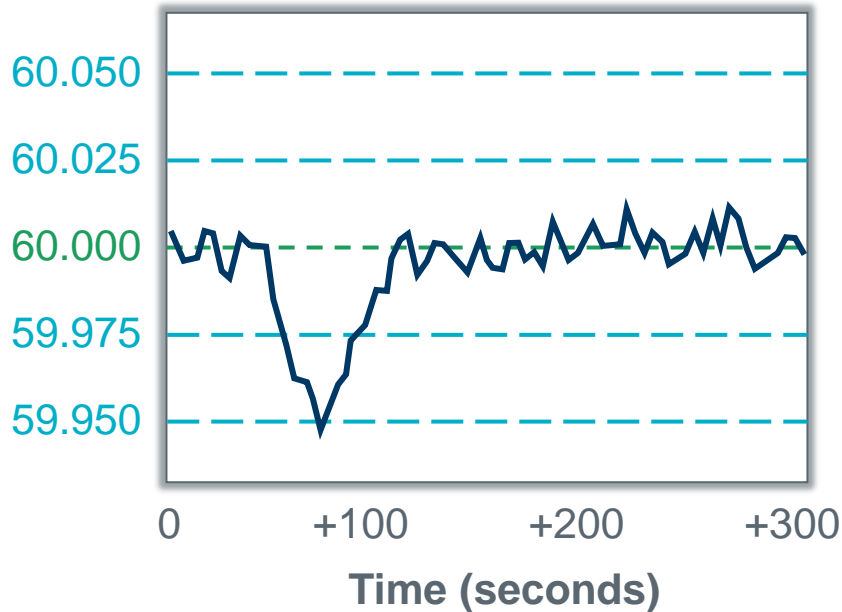

Frequency could spike when curtailment released

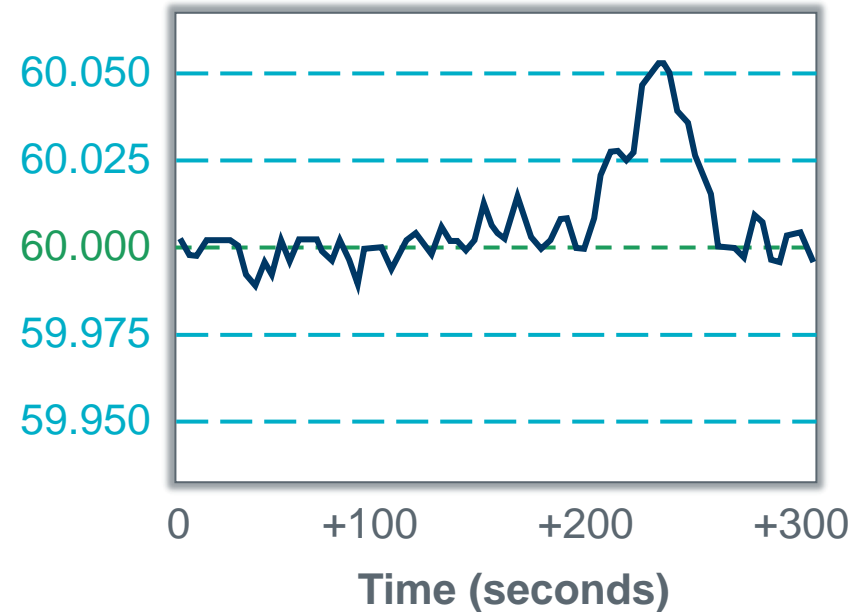

Large Ramp Rates

IRRs ramp rates limited to 20% of Nameplate Rating per minute

When curtailed by ERCOT

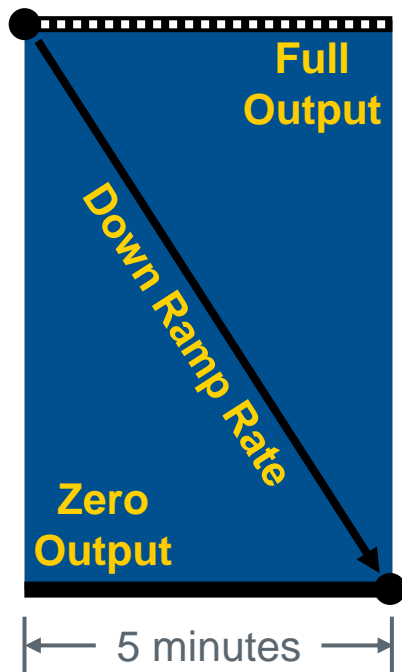

When released from curtailment by ERCOT

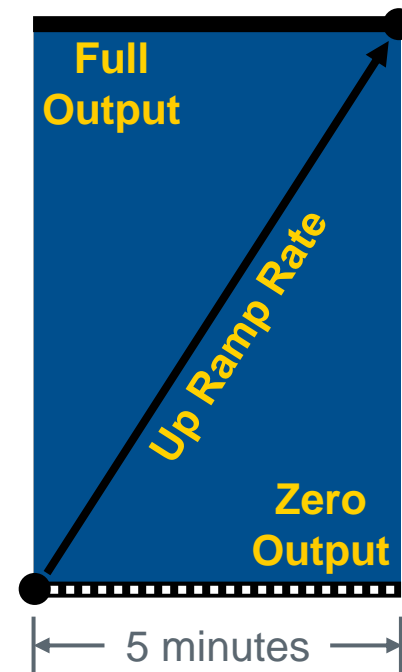

Not Traditional
Generators

All Resources must provide Primary Frequency Response

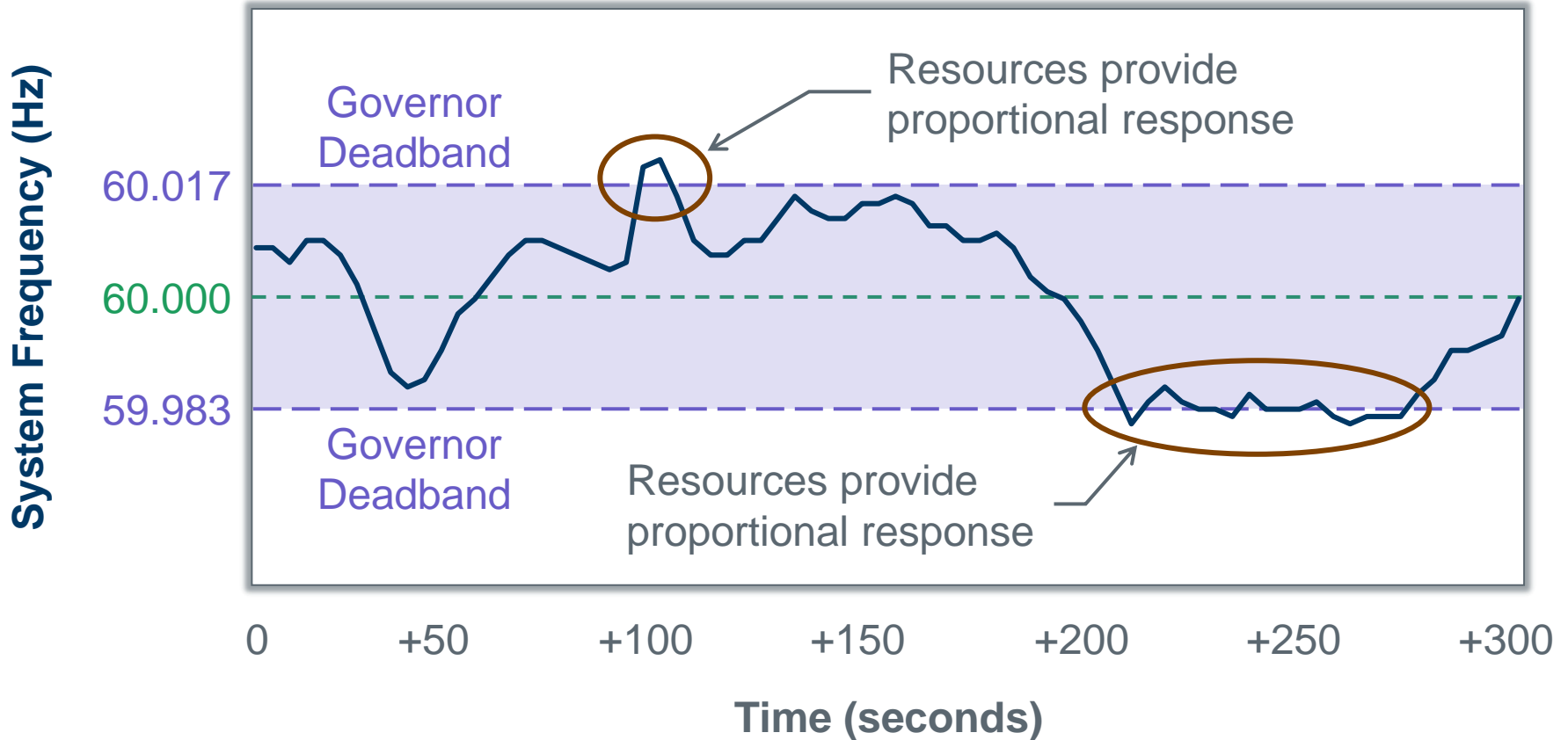

Not Traditional
Generators

All Generation Resources must provide Reactive Power

IRRs Operating at or above 10% Nameplate Rating

- Support voltage set point at POI¹
- Up to Unit Reactive Limit (URL)

If output is below 10% of
Nameplate, ERCOT may
request shutdown

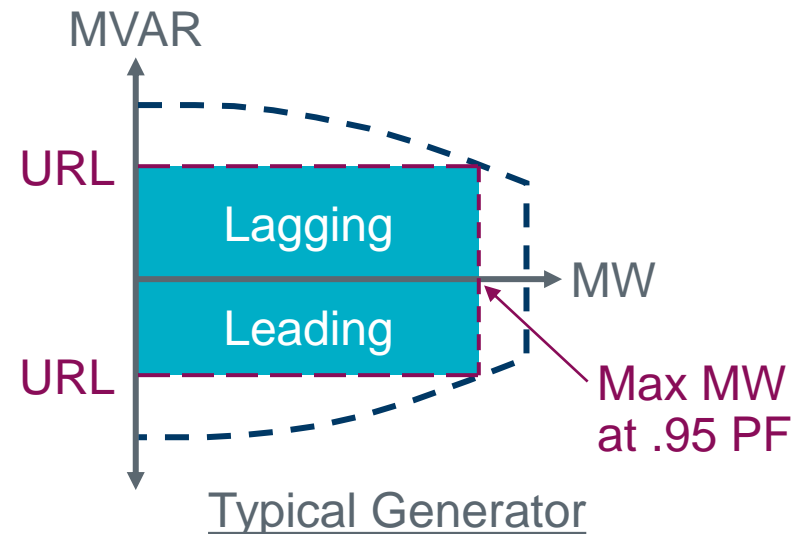

¹ Point of Interconnect

Location

Transmission
Constraints

Subsynchronous
Resonance

Challenges

- Interconnections far from load
- Potential Resonance from loss-compensation systems

**U.R. Nowhere
Power Plant**



Transmission Constraints

Potential constraints highlighted in Full Interconnection Study (FIS)

FIS Study Report includes:

- Nature of constraints
 - Stability
 - Overload
 - Base Case
 - Contingency Case
- Severity of constraints

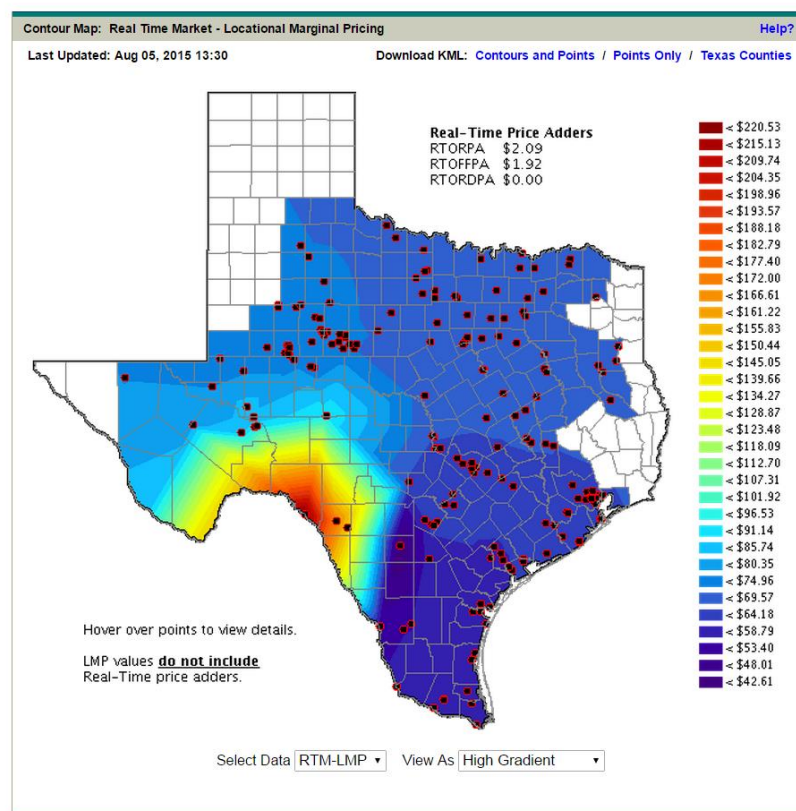

Subsynchronous Resonance

Series compensated lines may cause resonance at frequencies below 60Hz

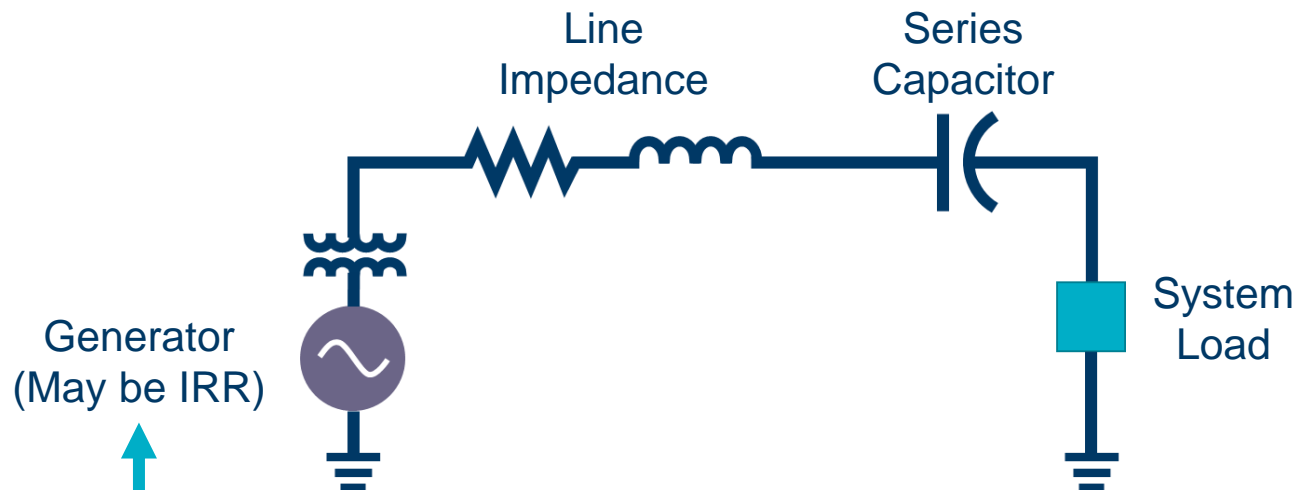

Resonance may damage Generators!

Bad Resonance

Subsynchronous Resonance

New Interconnecting Generation Resources

- Initial SSR¹ screening by ERCOT
- Vulnerability Assessment by TSP if needed



If countermeasures are required,

- Interconnecting Entity responsible
- Must be implemented prior to Initial Synchronization

¹Subsynchronous Resonance

Subsynchronous Resonance

Resources in the Planning Model

- Annual SSR¹ Review by ERCOT
- Vulnerability Assessment by TSP if needed



If countermeasures are required,

- TSP responsible
- Must be implemented by latter of
 1. Completion of transmission project
 2. Initial Synchronization

Module 3

IRR Forecasting

Topics in this module ...

- IRR Hourly Forecasting
 - Wind Generation
 - Photovoltaic Generation
- IRR Ramp Forecasting



IRR Hourly Forecasting



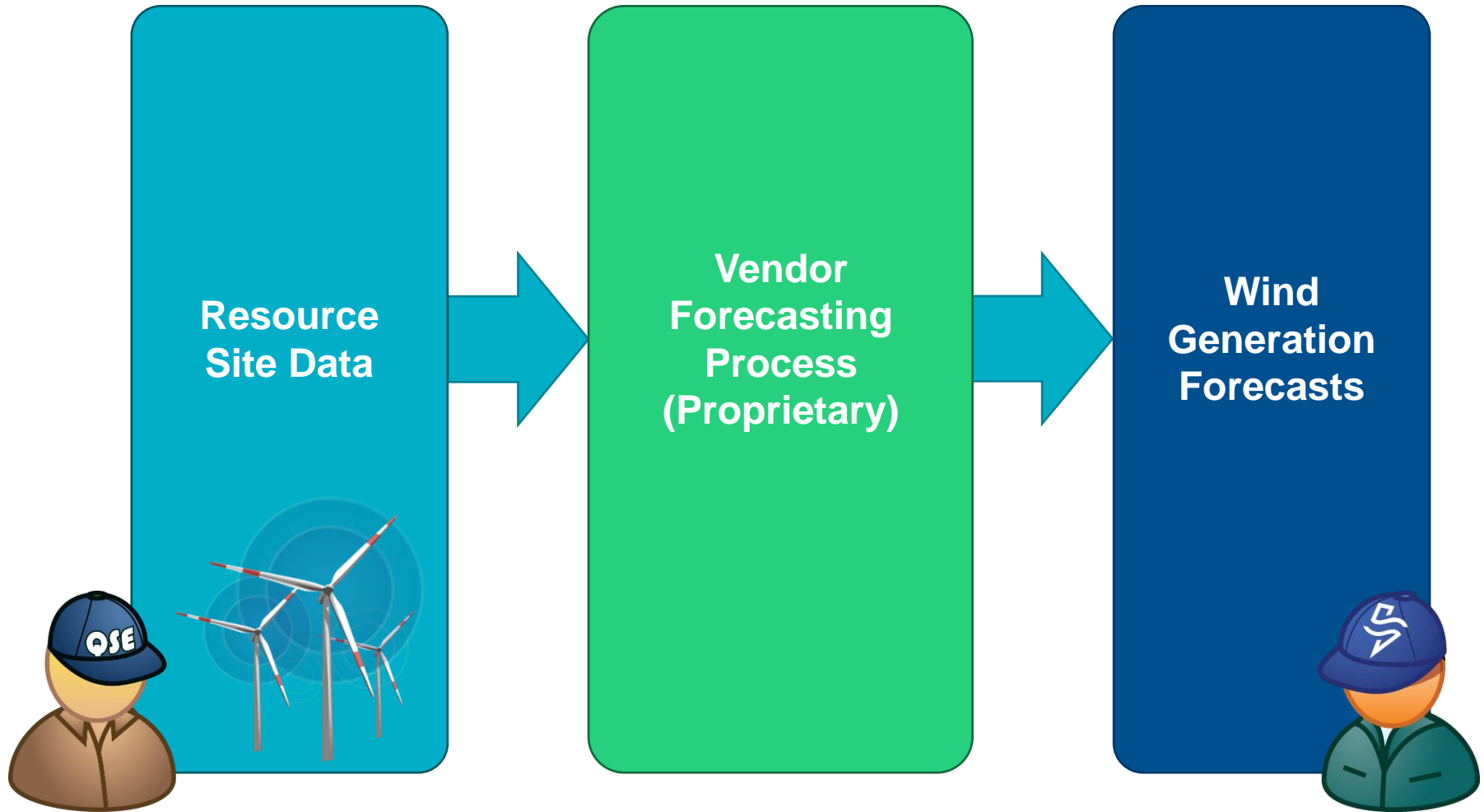

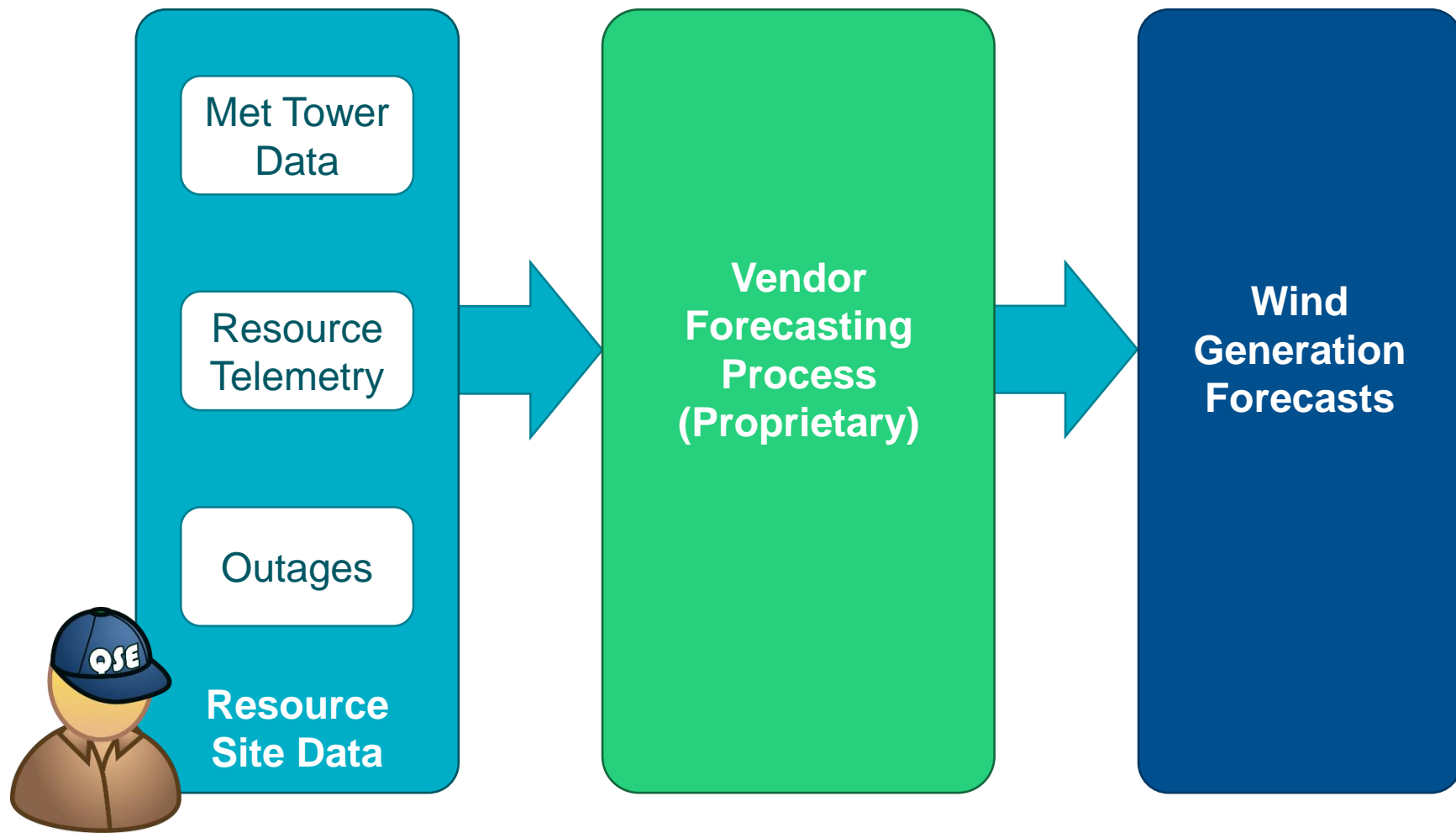

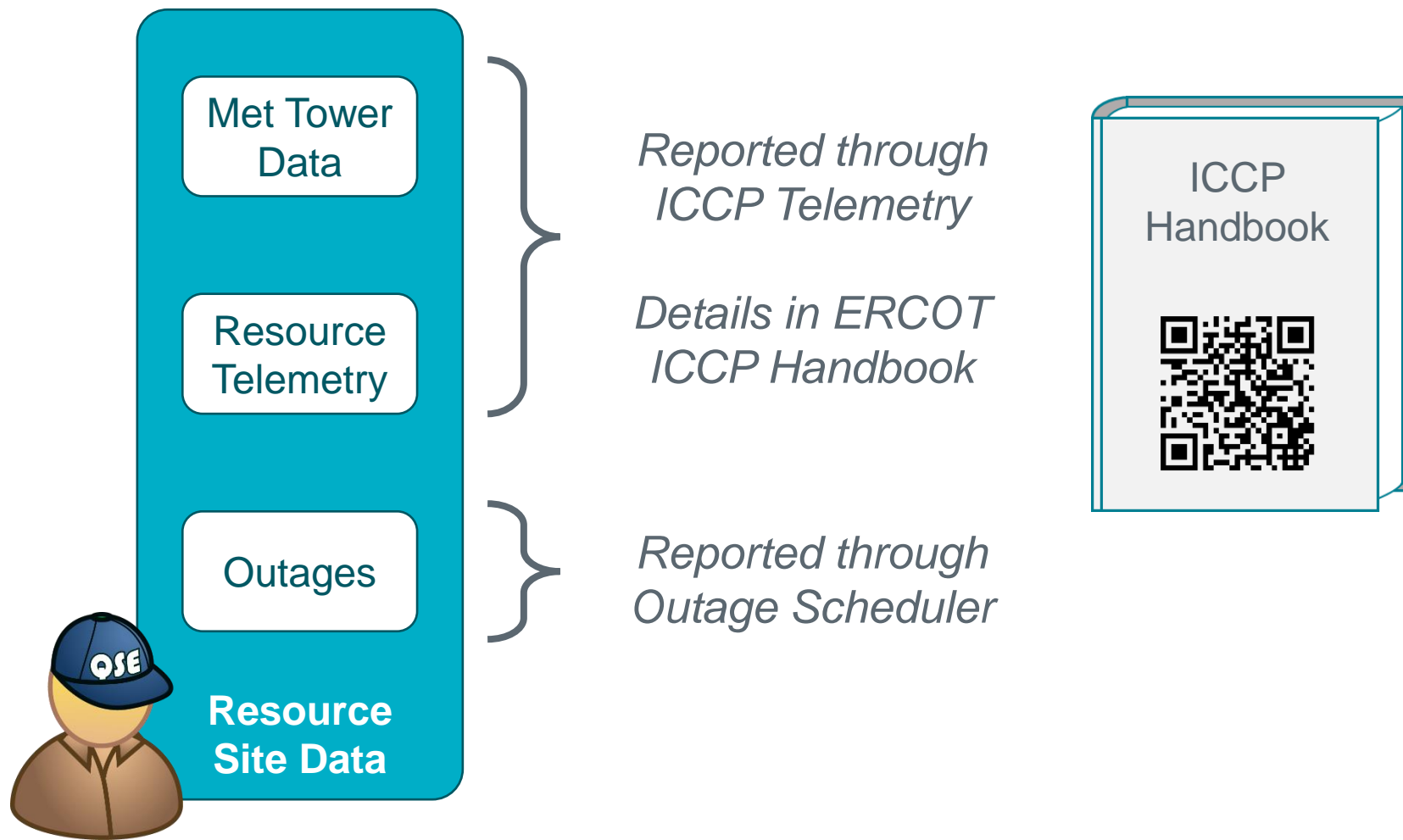

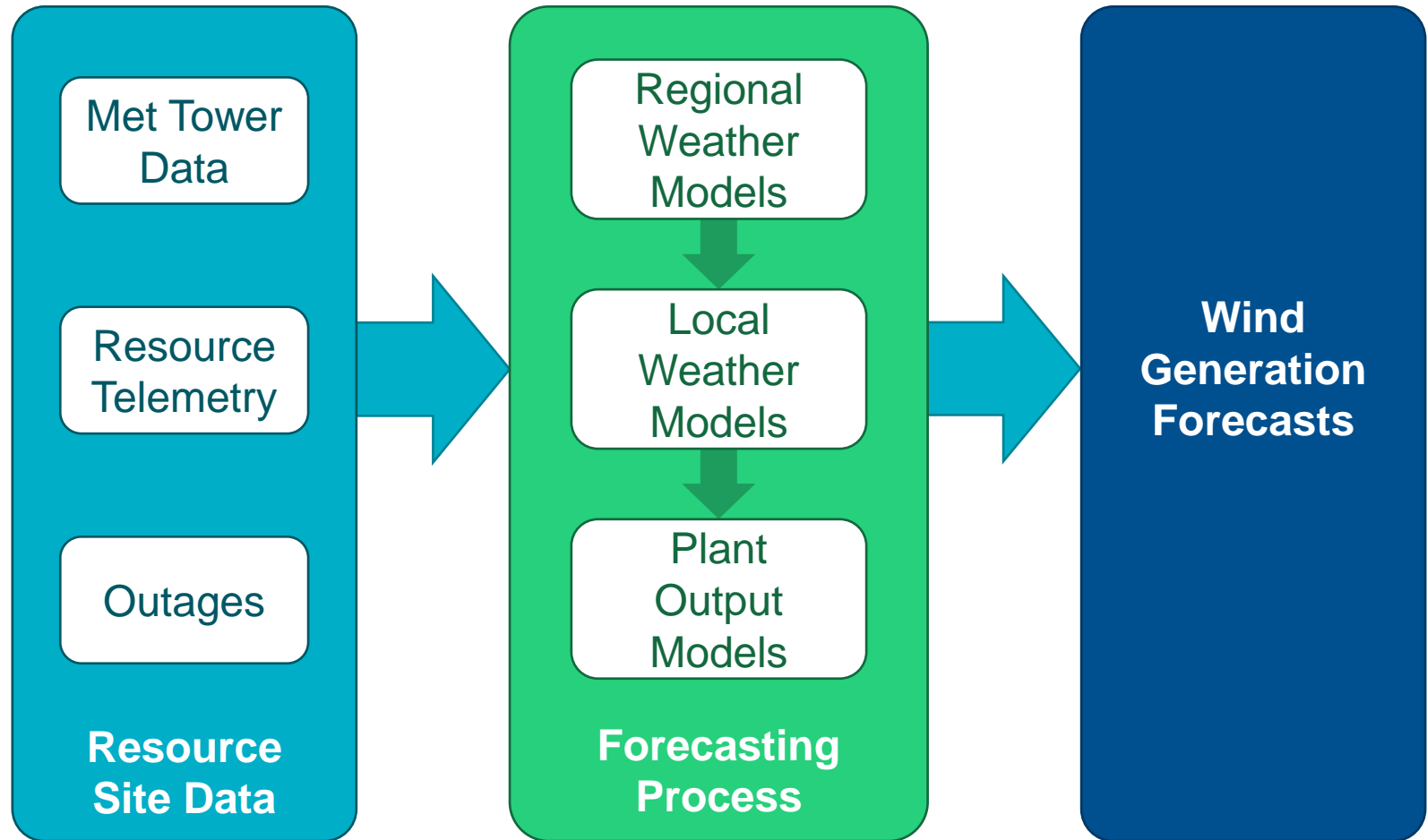

Ensemble of hourly forecasts

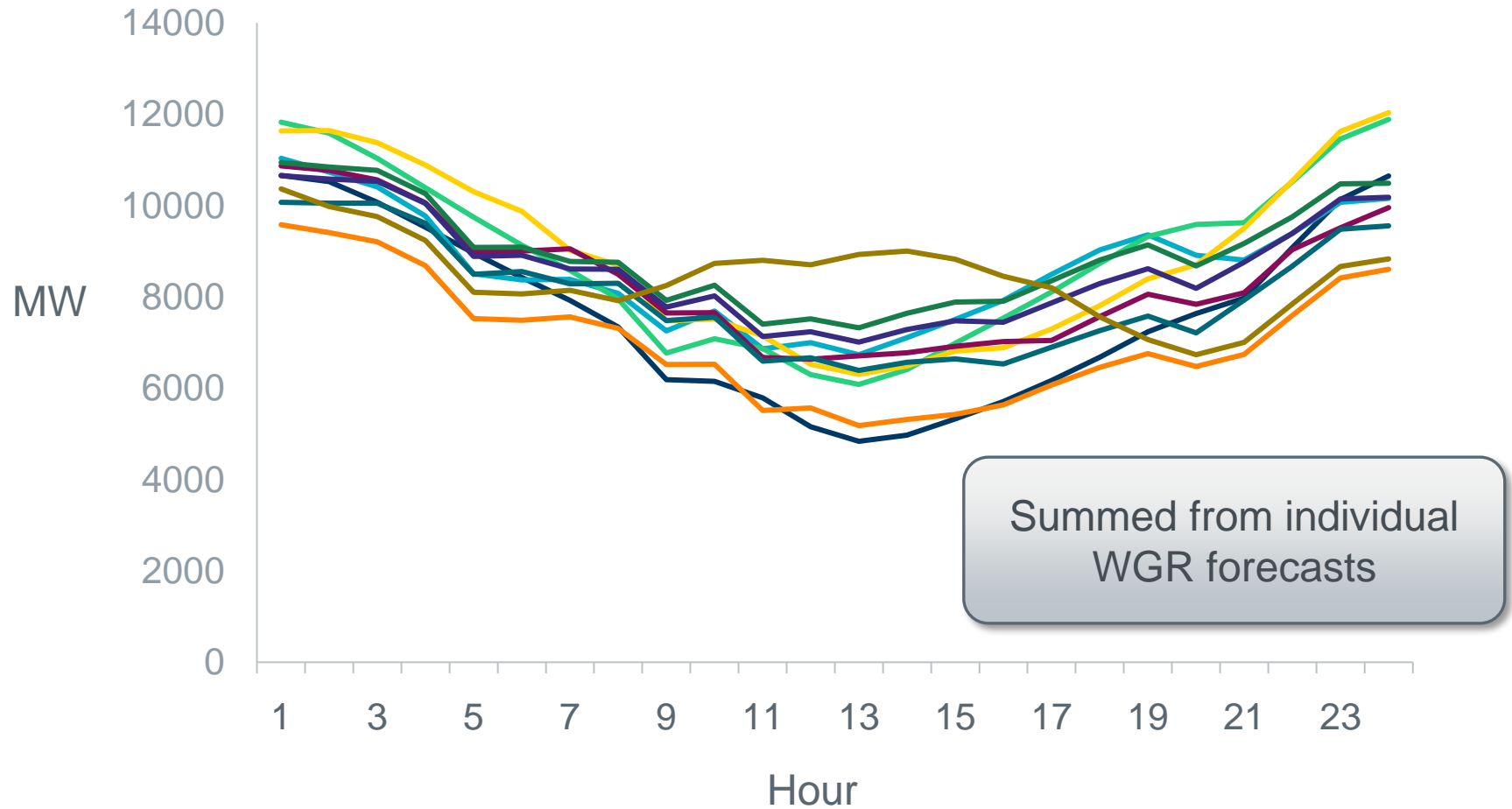

A Tale of Two Forecasts

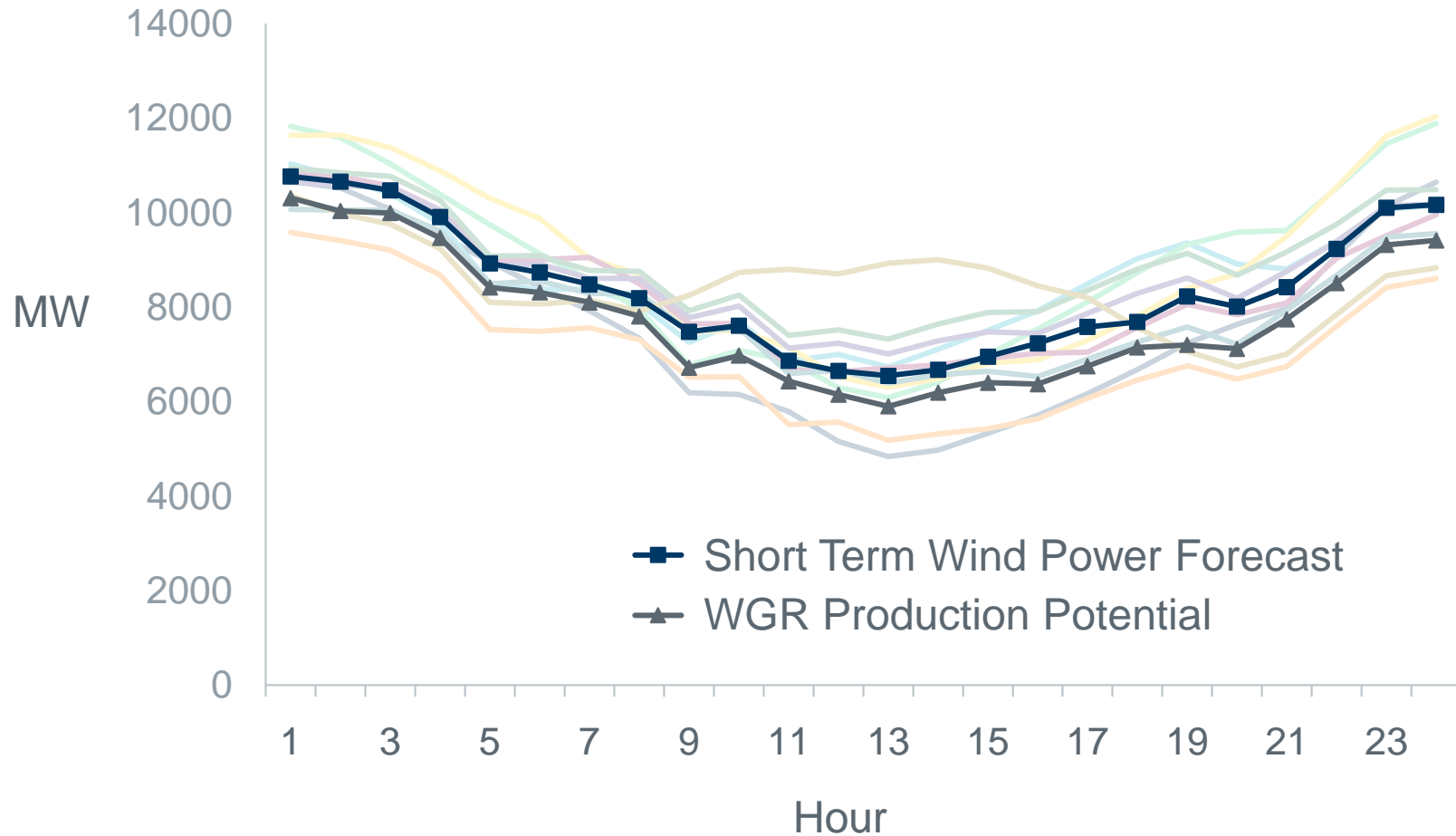



Short-Term Wind Power Forecast

- Rolling 168 hour forecast for each WGR
- Used in Reliability Unit Commitment

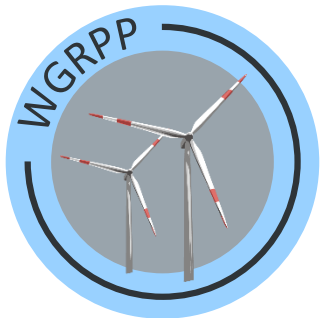

WGR Production Potential

- Rolling 168 hour forecast for each WGR
- Used in Control Room Operations and Planning

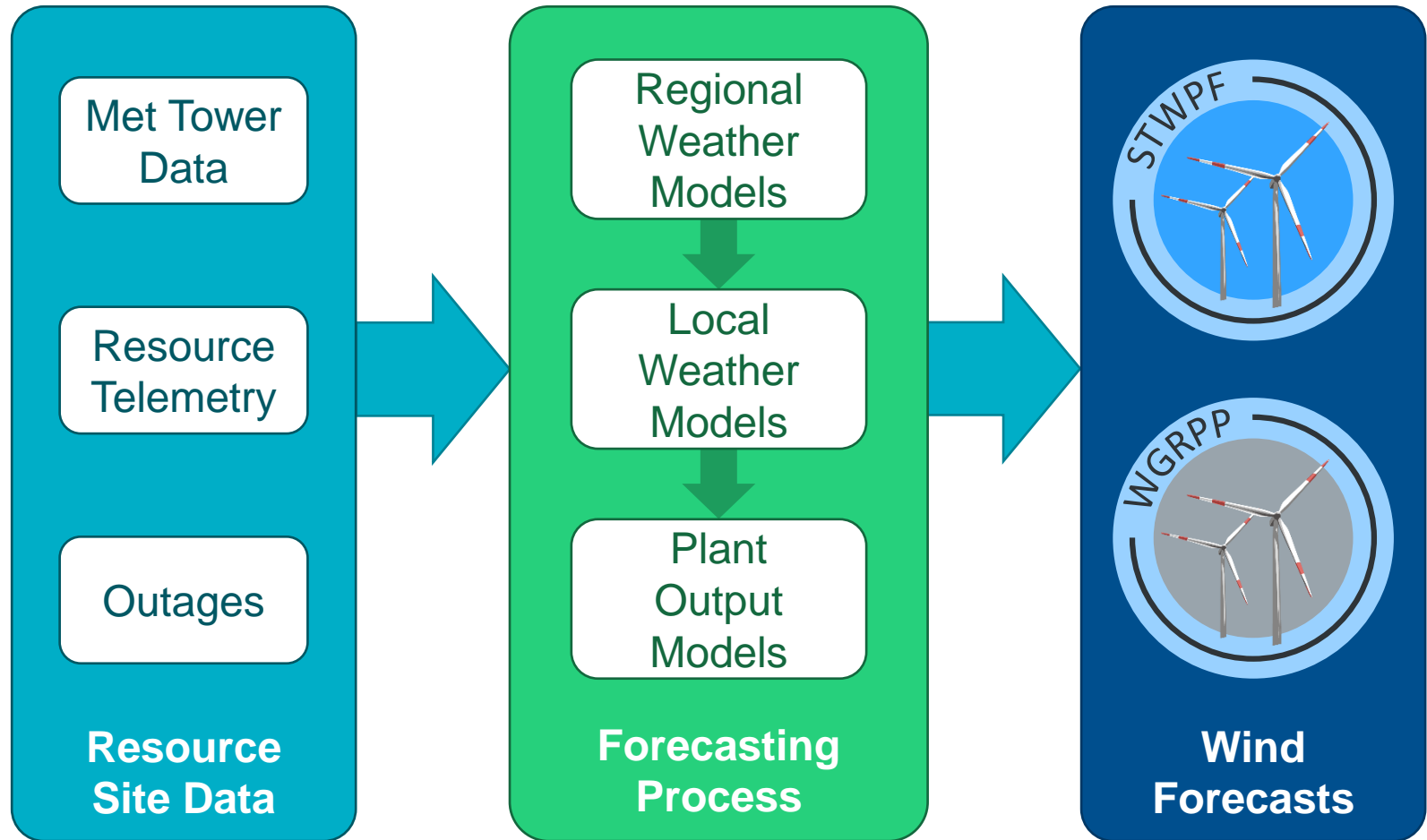

Discussion

WGR Dusty Mesa has just entered commercial operation

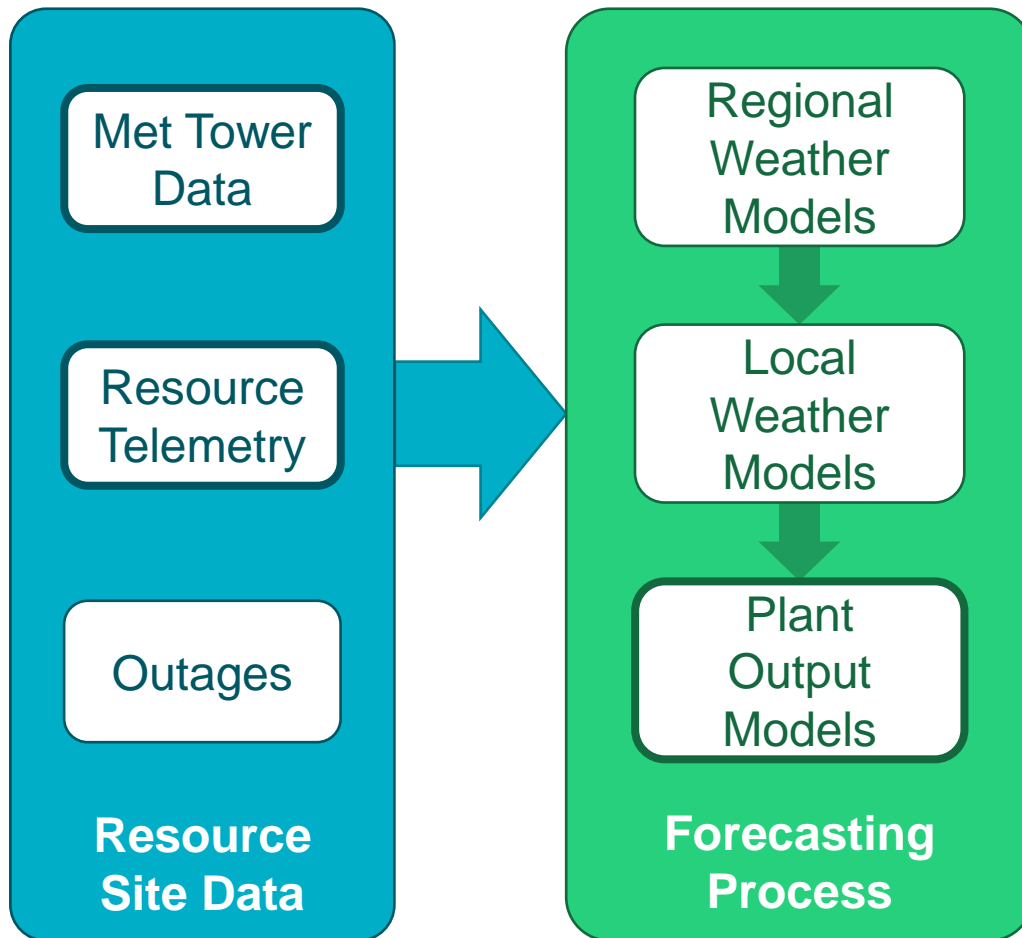

1. *What if telemetered power output is consistently low?*
2. *What if wind speed data is consistently low?*



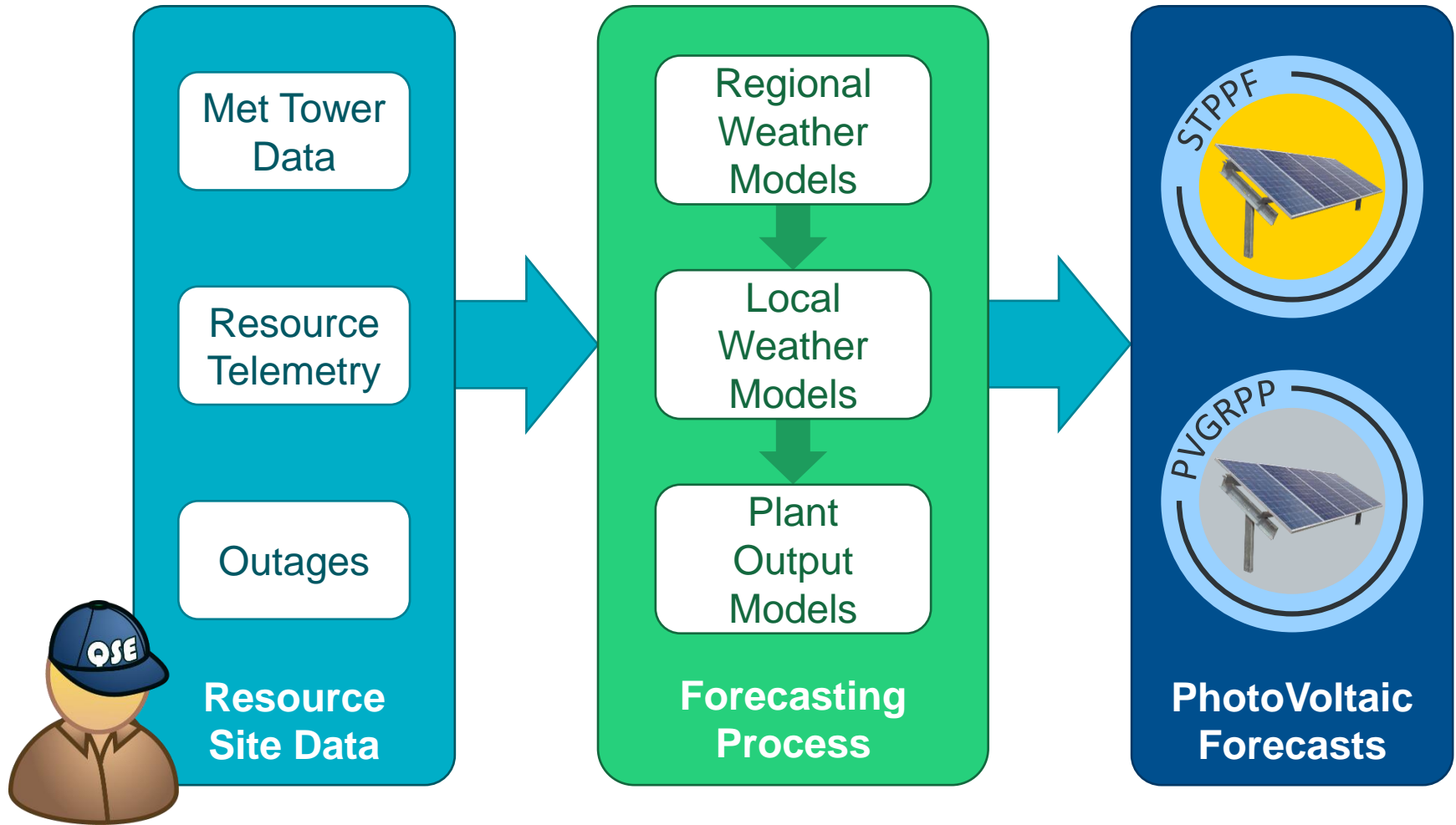

Ensemble of hourly forecasts

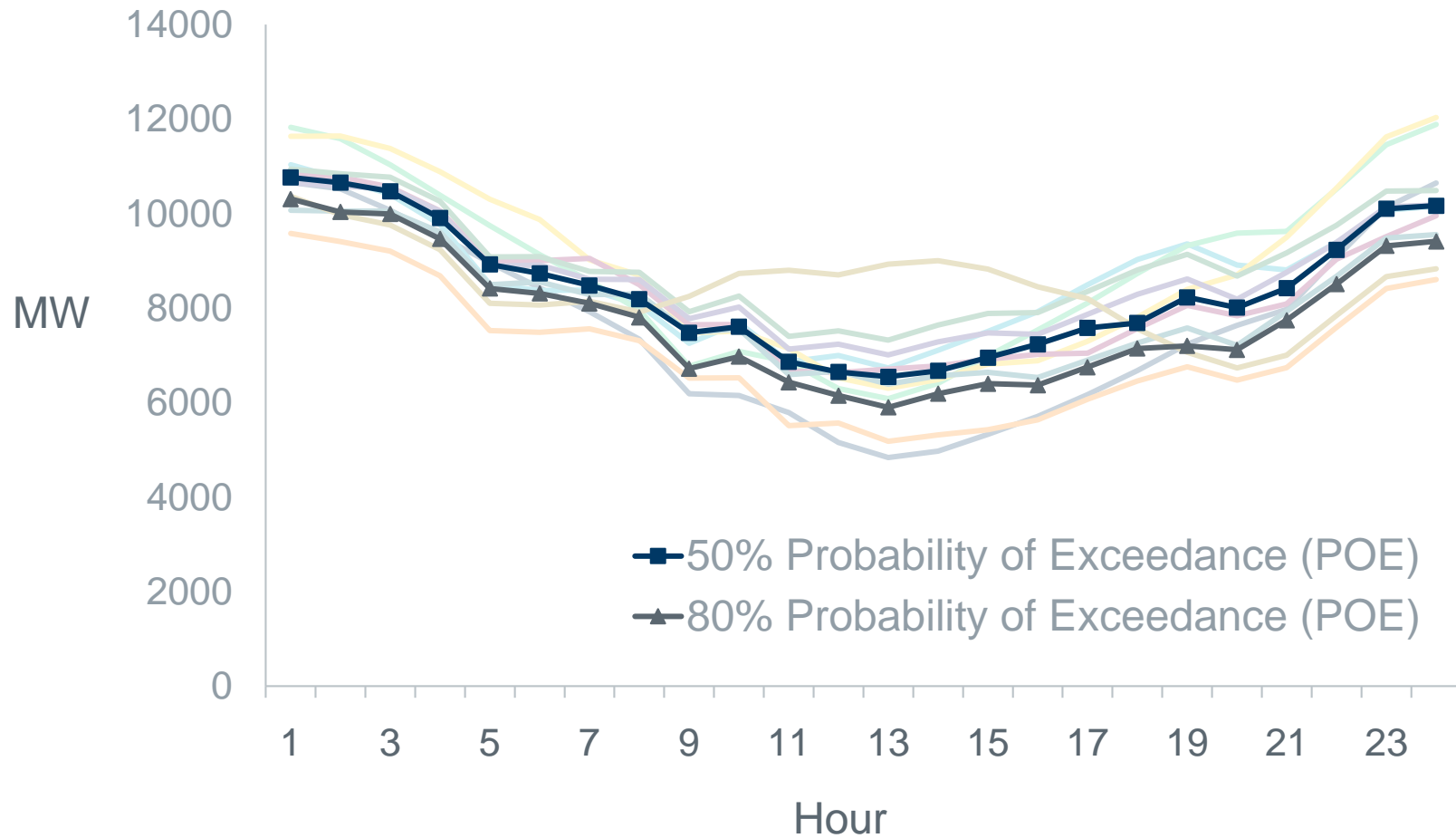



Short-Term Photovoltaic Power Forecast

- Rolling 168 hour forecast for each PVGR
- Used in Reliability Unit Commitment



PVGR Production Potential

- Rolling 168 hour forecast for each PVGR
- Used in Control Room Operations and Planning

Posted on MIS Hourly



- Individual WGR Forecasts
- Individual PVGR Forecasts



- Total WGR Forecasts
- Regional WGR Forecasts
- Total PVGR Forecasts
- Regional PVGR Forecasts

IRR Ramp Forecasting

Net Load = System Load – IRR Output

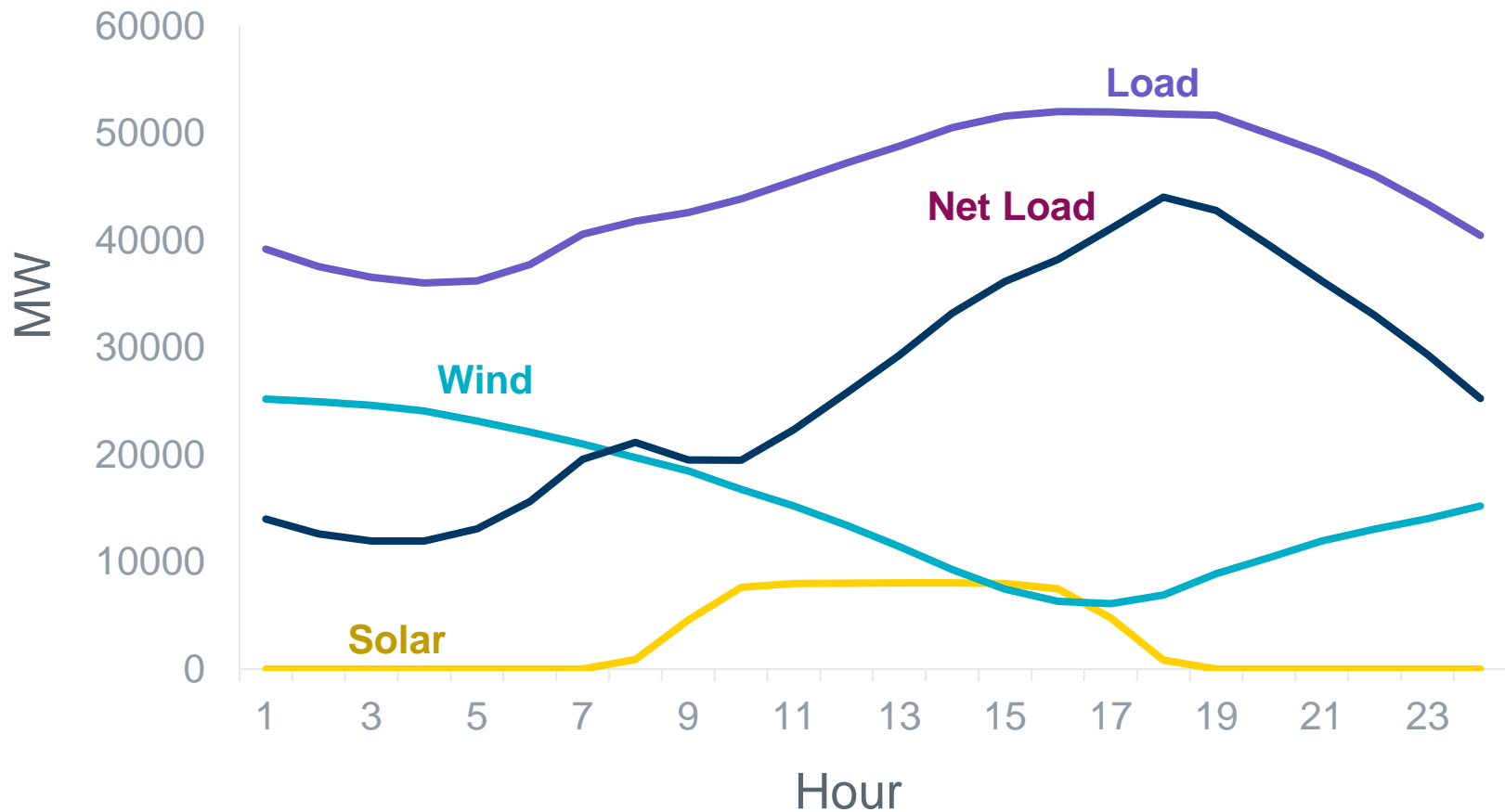

Capacity Available Tool (CAT)

- Assesses risk of large increase in Net Load
- Estimates adequacy of scheduled Generation and Reserves to manage risk

CAT study window
is six hours

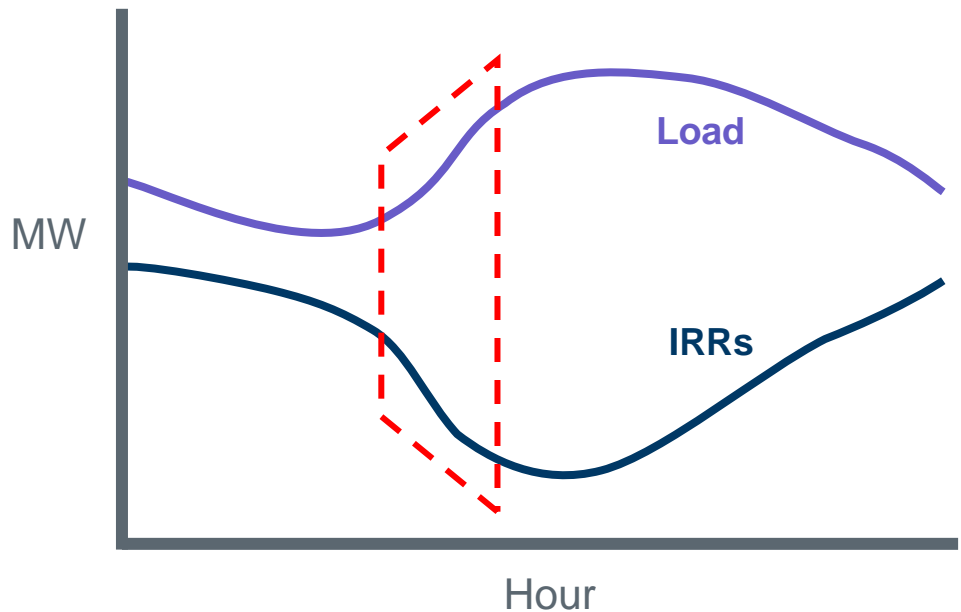

ERCOT Operators run CAT on demand

- Retrieves expected Generation schedules from COPs
- Considers historical forecast uncertainties
 - Wind
 - Solar
 - Load



ERCOT may take action to mitigate ramping risk

- Deploying Non-Spin Reserve
- Procuring additional Non-Spin Reserve
- Committing additional Resources through RUC

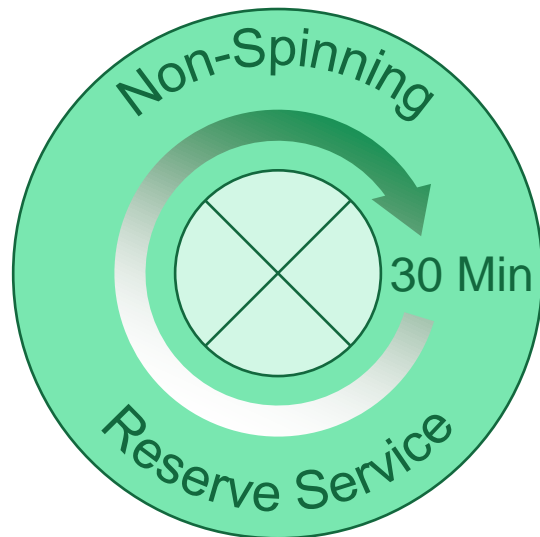

Module 4

IRRs in Market and System Operations

Topics in this module ...

- Preparing for Real-Time Operations
- IRRs during Real-Time Operations
- Dispatch Scenarios



Preparing for Real-Time Operations



Submit Energy Offer Curves



Update Current Operating Plan



Energy Offer Curves for IRRs

- Priced between $-\$250/\text{MWh}$ and SWCAP
- May be submitted or updated until the end of the Adjustment Period

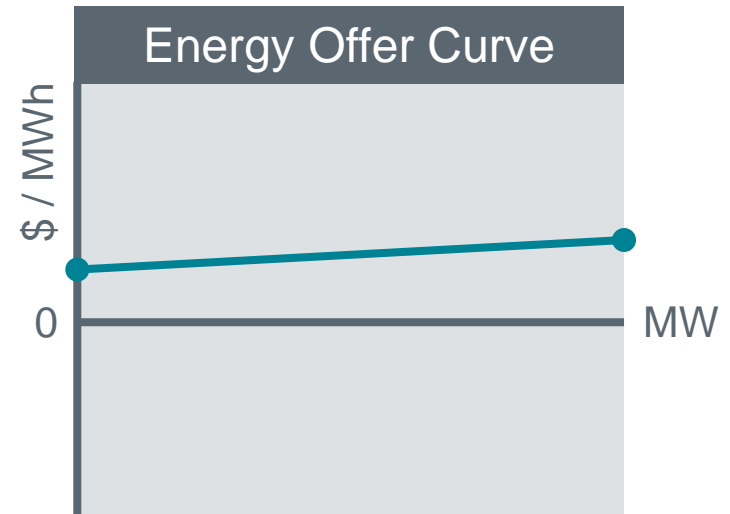

*NPRR 1058 allows updates within the Operating Hour
→ To be implemented 8/22/2024*

Discussion

What MW range should an IRR offer?

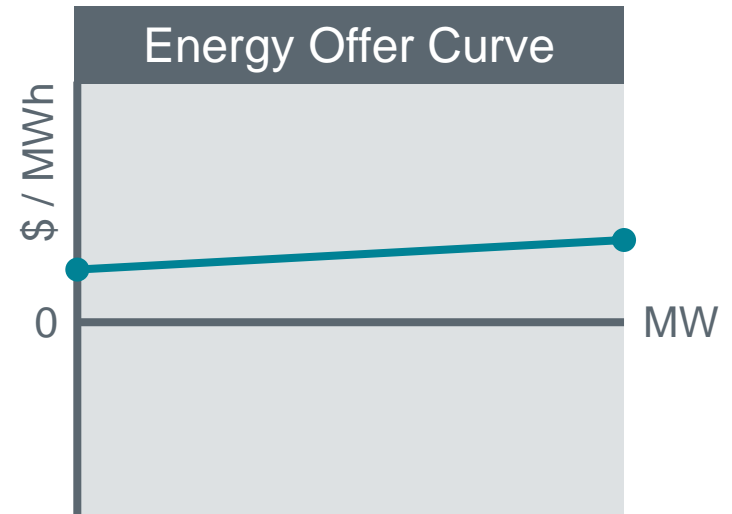



**Submit Energy
Offer Curves**



**Update Current
Operating Plan**



QSE must maintain a Current Operating Plan (COP) for each Resource

- Reflects expected status and capabilities for each hour
- May be updated until the end of the Adjustment Period
- Must be updated within 60 minutes of any event that impacts status or capabilities



Reliability Unit Commitment (RUC) Process

- Which Resources are planned to run
- How much capacity each Resource contributes



Typical COP Statuses for IRRs

- **ON:** QSE has committed to run the Resource
- **OFF:** Resource is offline but available for commitment
- **OUT:** Resource is not available

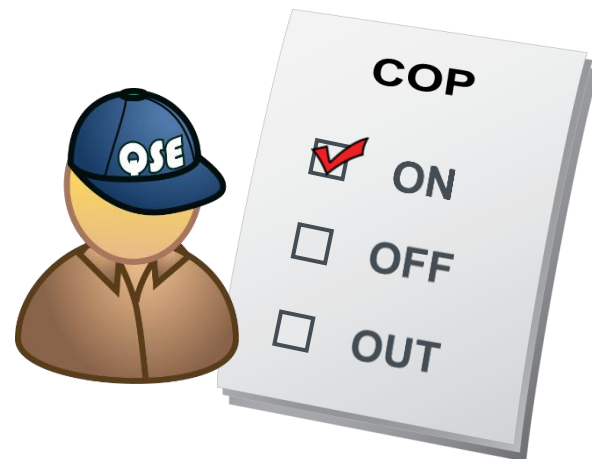

Discussion

What is the expected HSL for an IRR?

Wind-Powered Generation Resource (WGR):



Photovoltaic Generation Resource (PVGR):



IRRs During Real-Time Operations

Goals of SCED

- Manage reliability
 - Resolve Transmission Constraints
 - Match generation with demand
- Operate the system at least cost

SCED dispatches all available Resources in a way that achieves these goals

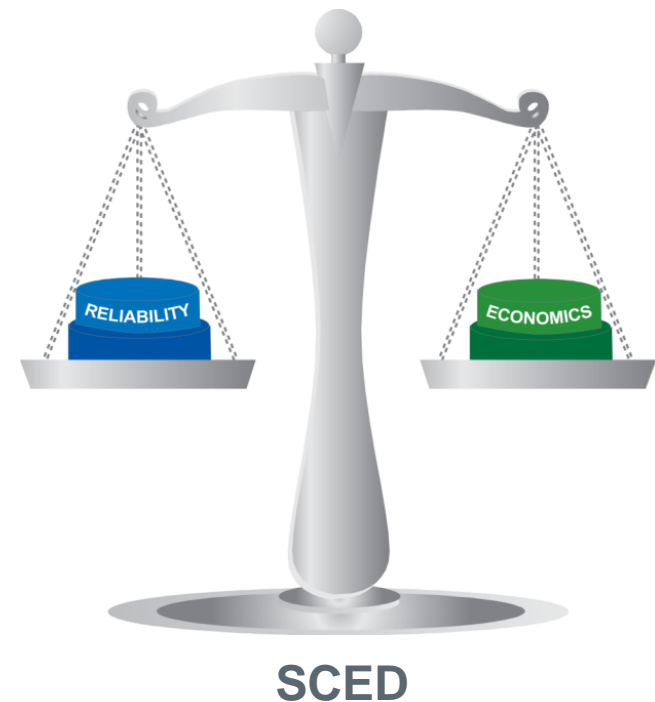

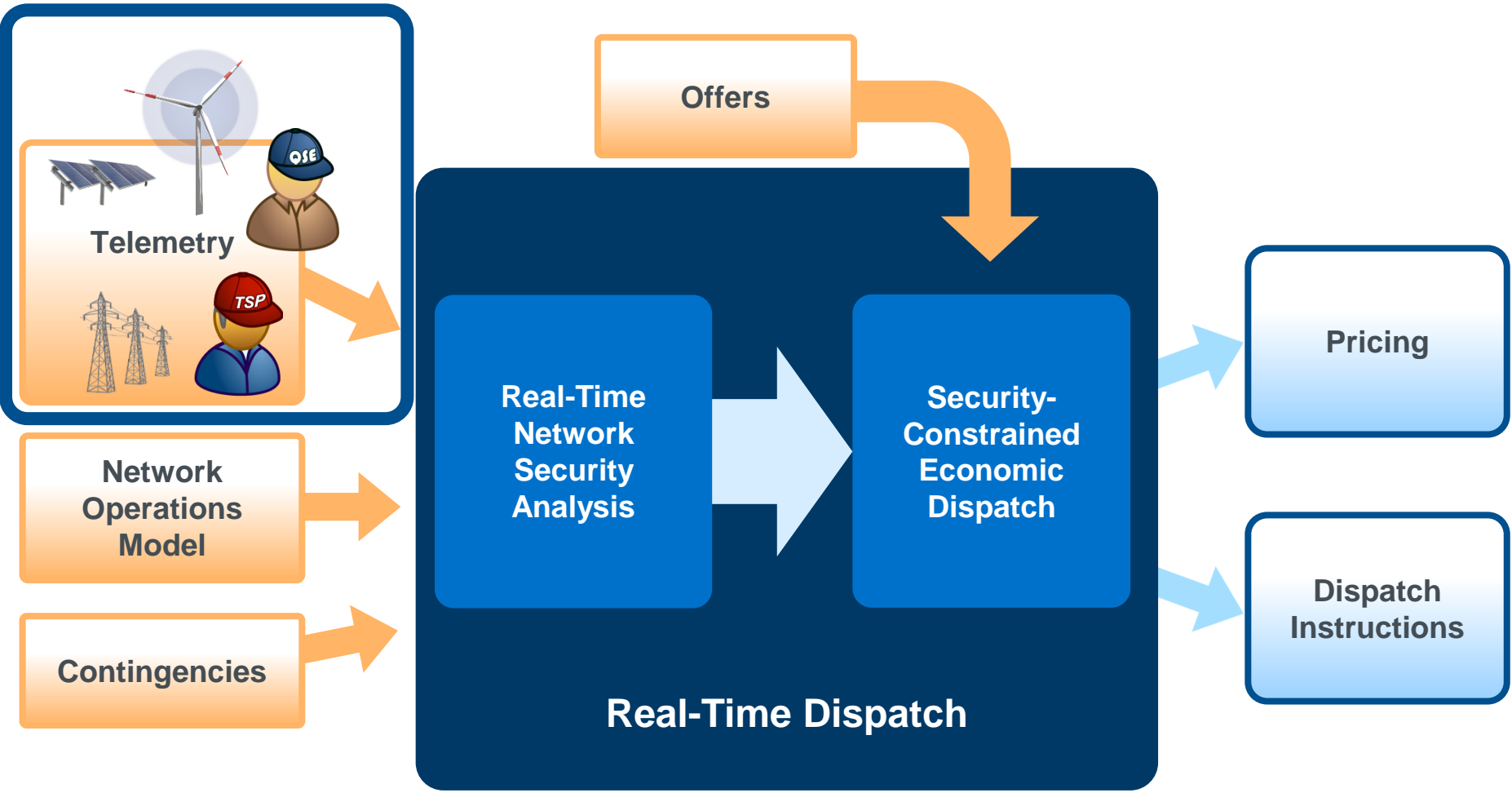

QSE Telemetry

- High Sustained Limit (HSL)
- Low Sustained Limit (LSL)
- Power Output
- Ramp Rates

Resource Limit Calculator

- High Dispatch Limit (HDL)
- Low Dispatch Limit (LDL)

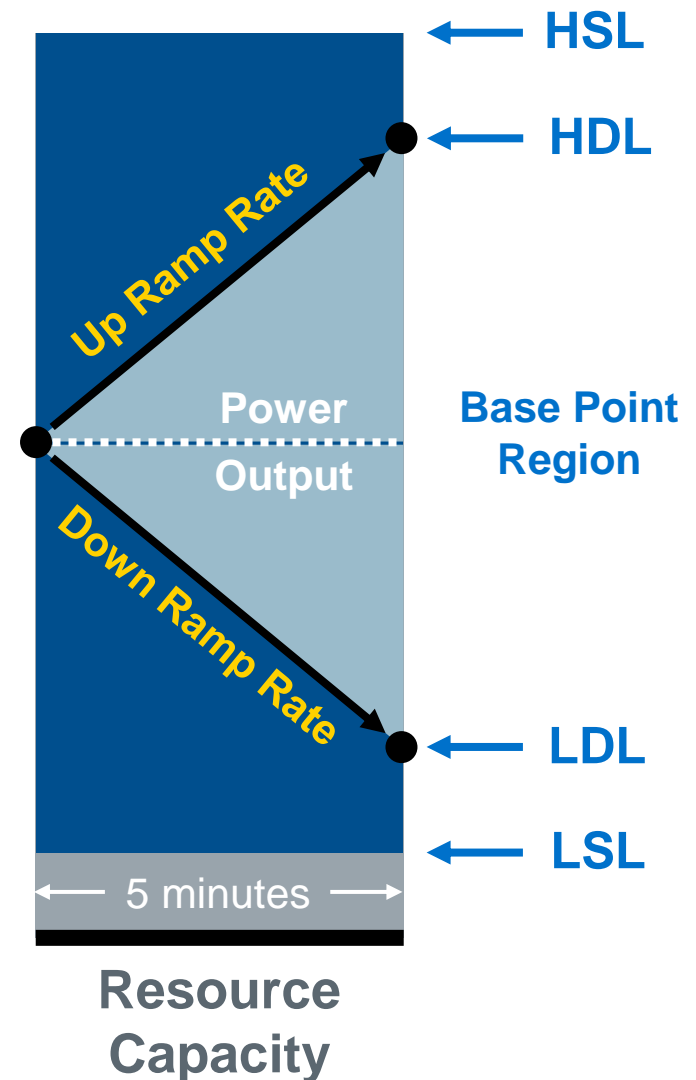

High Sustained Limit is not ...

- Nameplate rating
- Max output under ideal conditions

High Sustained Limit is ...

- Current net output capability
- Based on current conditions
 - Wind / Irradiance
 - Turbines / Inverters online



Goals of IRRs

1. Dispatch to follow energy supply
2. Operate at max capability

Goals of SCED

1. Dispatch to manage reliability
2. Operate the system at the least cost



Are IRR's goals competing
with SCED's goals?

Discussion

Fitting a square peg into a round hole?

1. *How does a QSE tell SCED how much the IRR has to offer?*
2. *How can a QSE make SCED take everything the IRR has to offer?*



Dispatch Scenarios

Scenarios

Real Time Dispatch of IRRs

1. IRR with Energy Offer Curve
2. Curtailed IRR with Energy Offer Curve
3. IRR is released from curtailment



Scenario 1

IRR is available for dispatch and not impacted by any binding constraints

- IRR runs at HSL
- IRR is a “Price-Taker”
- Base Point follows HSL

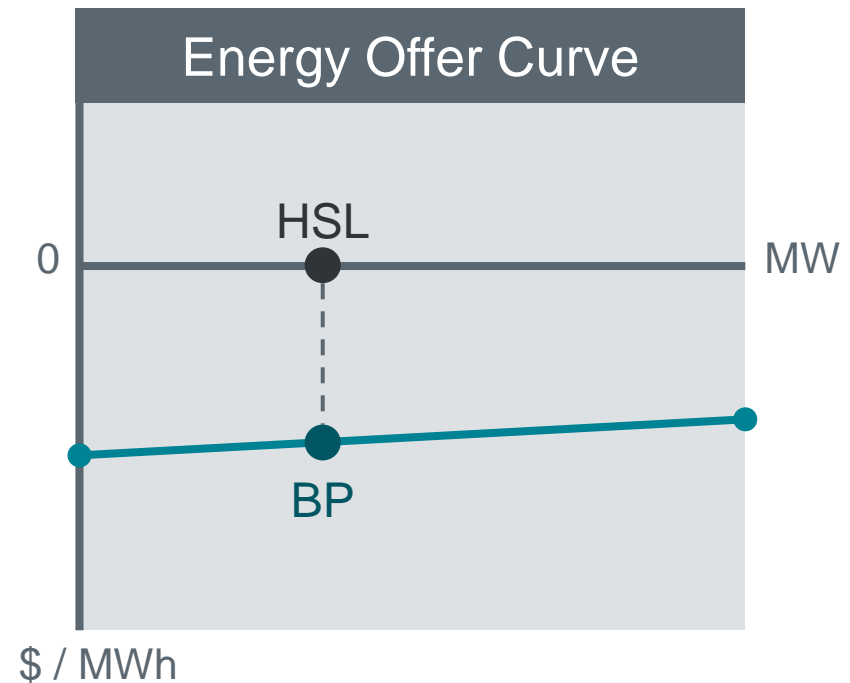

Scenario 2

IRR has positive shift factor on a binding constraint and must be curtailed

- Base Point is less than HSL
- IRR Energy Offer Curve sets LMP
- IRR must comply with Base Point

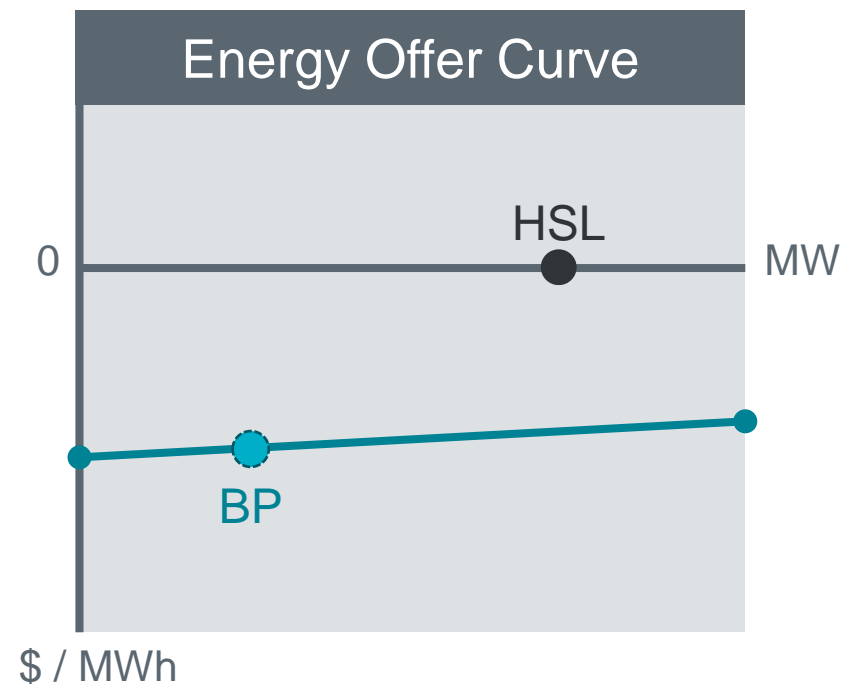

Scenario 2

IRR has positive shift factor on a binding constraint and must be curtailed

- SCED can move IRR from full output to any lower output in five minutes
- IRR must limit ramping to 20% of nameplate per minute

While curtailed, HSL should still represent current net output capability

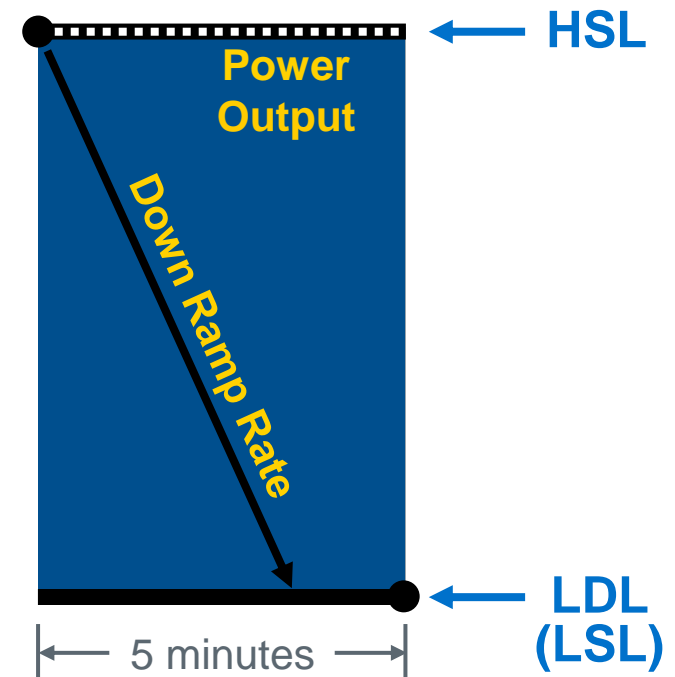

Scenario 3

IRR has been curtailed because of a constraint. Curtailment is now lifted.

- IRR becomes a “Price Taker” once again
- SCED will set Base Point to HSL again

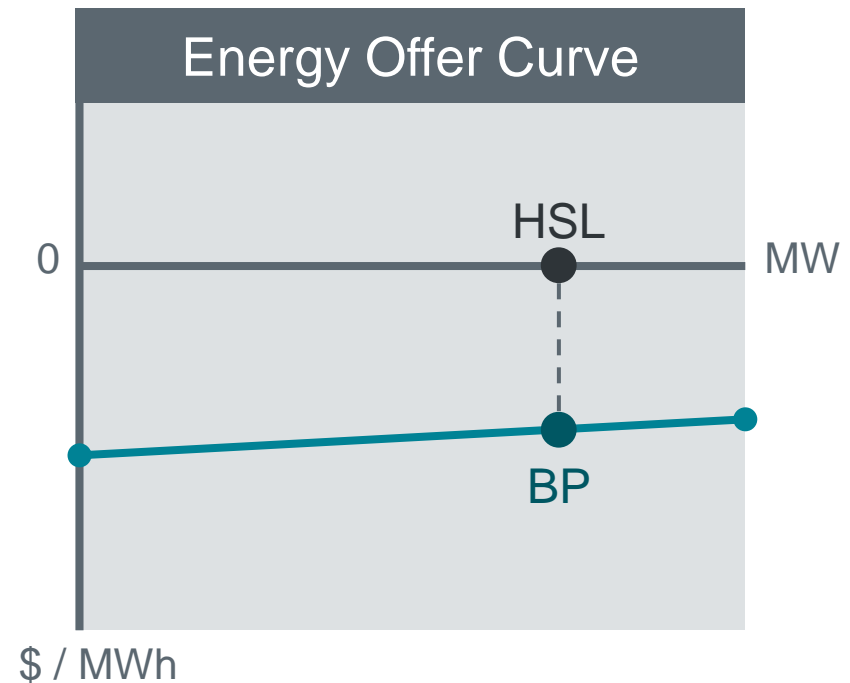

Scenario 3

IRR has been curtailed because of a constraint. Curtailment is now lifted.

- SCED can move IRR from curtailed output to full output in five minutes
- IRR must limit ramping to 20% of nameplate per minute

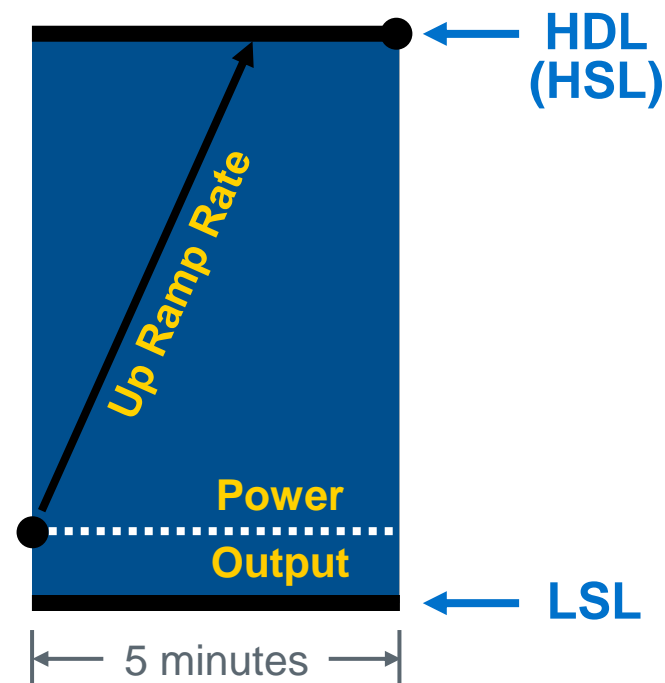

Module 5

Financial Settlements of IRRs

Topics in this module ...

- Real-Time Energy Imbalance
- Base Point Deviation Charge



Real-Time Energy Imbalance

Real-Time Energy Imbalance at a Resource Node:

$$\begin{aligned} & (-1) \left(\left(\begin{array}{c} \text{DAM Energy Purchases} \\ + \\ \text{Trade Energy Purchases} \end{array} \right) - \left(\begin{array}{c} \text{DAM Energy Sales} \\ + \\ \text{Trade Energy Sales} \end{array} \right) \right) * \text{RTSPP} \\ & + (-1) \left(\text{Metered Generation} \right) * \text{RTRMPR} \end{aligned}$$

At a Resource Node,

RTSPP is used to settle financial transactions

$$\text{RTSPP} = \text{RTRSVPOR} + \text{RTRDP} + \text{Time-Weighted Average} \left(\text{LMPs} \right)$$

RTSPP	Real-Time Settlement Point Price
RTRSVPOR	Real-Time Reserve Price for On-Line Reserves
RTRDP	Real-Time On-Line Reliability Deployment Price



At a Resource Node,

RTRMPR is used to settle physical energy production

$$\mathbf{RTRMPR} = \mathbf{RTRSVPOR} + \mathbf{RTRDP} + \text{(Base-Point * Time) Weighted Average} \left(\text{LMPs} \right)$$

RTRMPR	Real-Time Resource Meter Price
RTRSVPOR	Real-Time Reserve Price for On-Line Reserves
RTRDP	Real-Time On-Line Reliability Deployment Price



Scenario 4

QSE Schedules Energy Trades on their IRR, Solaris Ventum

- 100 MW nameplate rating
- On-line continuously in Real-Time
- Trade Energy Sale of 40MW during Hour 1600
- During Interval 1515
 - Produces 10 MWh
 - RTSPP = \$30.00
 - RTRMPR = \$30.02

Scenario 4

Real-Time Energy Imbalance for Interval 1515:

$$\begin{aligned}
 (-1) & \left(\left(\begin{array}{c} \text{DAM Energy Purchases} \\ + \\ \text{Trade Energy Purchases} \end{array} \right) - \left(\begin{array}{c} \text{DAM Energy Sales} \\ + \\ \text{Trade Energy Sales} \end{array} \right) \right) * \text{RTSPP} \\
 & + (-1) \left(\text{Metered Generation} \right) * \text{RTRMPR}
 \end{aligned}$$

Which simplifies and re-arranges to . . .

$$(-1) * \left(\begin{array}{c} \text{Metered} \\ \text{Generation} \end{array} * \text{RTRMPR} - \left(\begin{array}{c} \text{DAM Energy Sales} \\ + \\ \text{Trade Energy Sales} \end{array} \right) * \text{RTSPP} \right)$$

Trades in Real-Time Energy Settlements

- Energy Trades are reported as hourly MWs
- Real-Time is settled as 15-minute MWs

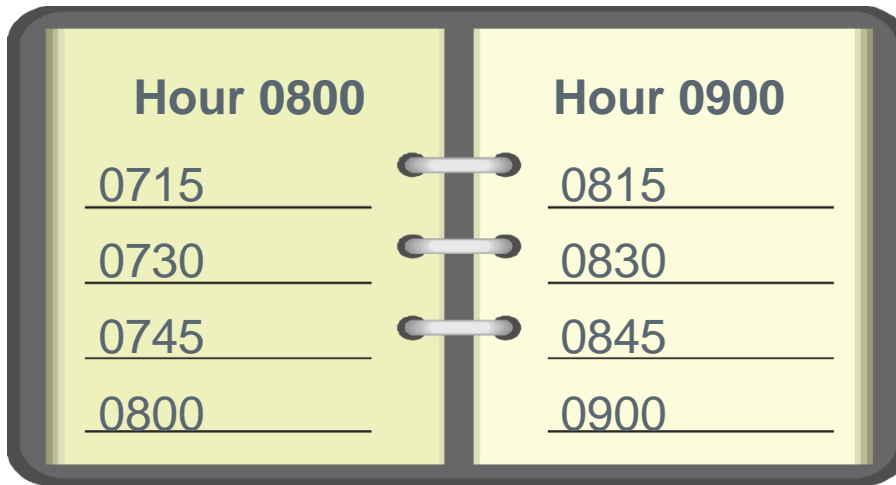

Hour 0800	Hour 0900
<u>0715</u>	<u>0815</u>
<u>0730</u>	<u>0830</u>
<u>0745</u>	<u>0845</u>
<u>0800</u>	<u>0900</u>

Trades must be multiplied by $\frac{1}{4}$ hour

Scenario 4

Real-Time Energy Imbalance for Interval 1515:

$$(-1) * \left(\text{Metered Generation} * \text{RTRMPR} - \left(\begin{array}{c} \text{DAM Energy Sales} \\ + \\ \text{Trade Energy Sales} \end{array} \right) * \text{RTSPP} \right)$$

$$(-1) * \left(\quad ? \quad \right) = ?$$

Base Point Deviation Charge

Key Differences between Intermittent Renewable Resources (IRRs) & other Resources

IRR must be Curtailed

- Curtailment Flag

IRR must be Over-Generating

- Telemetered generation
- Instructed Base Point



When are IRRs exposed to deviation charges?

	IRR output <u>within</u> 5% acceptable range	IRR output <u>exceeds</u> 5% acceptable range
Curtailement Flag is not set	No Charge	No Charge
Curtailement Flag <u>is</u> set	No Charge	<u>Charge</u>

IRR Groups are assessed as an aggregate

Scenario 5

IRR Solaris Ventum is curtailed. How is the QSE settled?

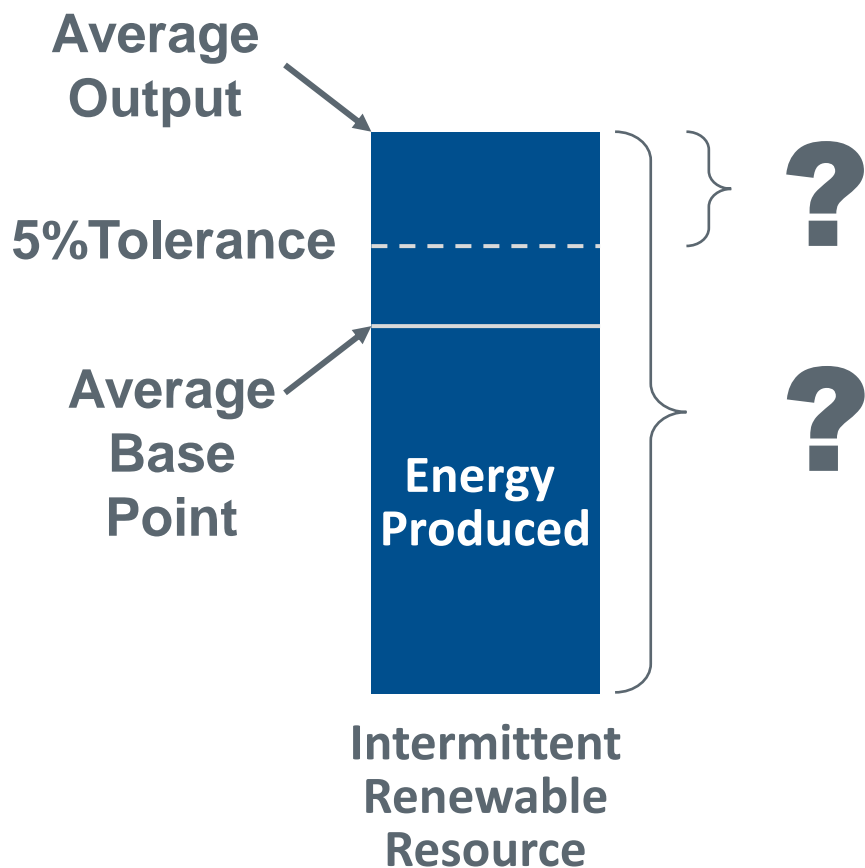

Course Wrap-Up

[Home](#) > [Grid Information](#) > [Generation](#)

Generation

This page provides current information on Generation Resources, including forecast and actual generation for Wind and PhotoVoltaic (Solar) Generation Resources; Resource Outages; Reliability Unit Commitment (RUC) constraints; Reliability Must Run (RMR) Resource deployments; Fuel Type; and aggregate High and Low Dispatch Limits (HDL, LDL) in the ERCOT region. The Key Documents section provides links to supporting documents related to resource asset registration, Outage scheduling, and monthly ERCOT Wind Integration Reports.

Intermittent Renewable Resources

[Aggregated Solar Resource Power Potential Forecast](#)

This report is posted every hour and includes System-wide STPPF and PVGRPP for On-Line PVGRs for the rolling future 168-hour period.

[Hourly System-wide and Regional STWPF and WGRPP by Forecast Model](#)

This report is posted every hour and includes system-wide and regional STWPF and WGRPP values produced by each forecast model for On-Line WGRs for the rolling future 168-hour period and also indicates which forecast model is used for each region to populate COPs.

[Intra-Hour Wind Power Forecast By Geographical Region](#)

Intra-Hour Wind Power Forecast (IHWPF) by wind region that provides a rolling two hour, five minute forecast of ERCOT-wide wind production potential.

[Solar Power Production - Actual 5-Minute Averaged Values](#)

This report is posted every 5 minutes and includes System-wide actual 5-minute averaged solar power production for On-Line PVGRs for a rolling historical 60-minute period.

[Solar Power Production - Hourly Averaged Actual and Forecasted Values](#)

This report is posted every hour and includes System-wide actual hourly averaged solar power production, STPPF, PVGRPP, and COP HSLs for On-Line PVGRs for a rolling historical 48-hour period as well as the System-wide STPPF, PVGRPP and COP HSLs for On-Line PVGRs for the rolling future 168-hour period.

[Wind Power Production - Actual 5-Minute Averaged Values](#)

This report is posted every 5 minutes and includes System-wide and Regional actual 5-minute averaged wind power production for a rolling historical 60-minute period.

[Wind Power Production - Hourly Averaged Actual and Forecasted Values](#)

This report is posted every hour and includes System-wide and Regional actual hourly averaged wind power production, STWPF, WGRPP and COP HSLs for On-Line WGRs for a rolling historical 48-hour period as well as the System-wide and Regional STWPF, WGRPP and COP HSLs for On-Line WGRs for the rolling future 168-hour period.

[Home](#) > [Grid Information](#) > [Generation](#) > Wind and Solar Integration Reports

Wind and Solar Integration Reports

These reports provide a system-wide overview of wind and solar generation at ERCOT. The reports and their contents are listed below.

Dashboards

[Combined Wind and Solar](#)

Combined Wind and Solar is a graphical representation of the most recent estimated wind and solar power production amounts for the Current Operating Day (COP).

Reports

[IRR Forecasting Process](#)

Describes the process used to forecast IRR capacity on a rolling 168 hour basis.

[PVGR Integration Report](#)

Contains high-level statistical highlights of solar generation and penetration, including daily peak load and solar penetration during that hour, as well as daily and all-time peak solar generation and penetration. Also provides graphs displaying: actual solar output vs. actual load, over a day; actual solar output as a percentage of the total installed solar capacity; actual solar output as a percentage of the ERCOT load; and actual solar output vs. ERCOT load, for the week prior to the report's creation.

[Wind Integration Report](#)

Contains high-level statistical highlights of wind generation and penetration, including daily peak load and wind penetration during that hour, as well as daily and all-time peak wind generation and penetration. Also provides graphs displaying: actual wind output vs. actual load, over a day; actual wind output as a percentage of the total installed wind capacity; actual wind output as a percentage of the ERCOT load; and actual wind output vs. ERCOT load, for the week prior to the report's creation.

ERCOT Protocols

<http://www.ercot.com/mktrules/nprotocols/>

ERCOT Training

<http://www.ercot.com/services/training/>

ERCOT Account Management Services

ErcotAccountManagers@ercot.com

ERCOT Market Education Contact

Training@ercot.com

Scan this QR code to take the course survey!

<https://www.surveymonkey.com/r/ERCOTILT>

