



Item 8: Panhandle Regional Planning Group Project

Jeff Billo

Senior Manager, Transmission Planning

Board of Directors Meeting

ERCOT Public

December 8, 2015

Background

History

- 2010: ABB Competitive Renewable Energy Zone (CREZ) Reactive Study identified future need for synchronous condensers in the Panhandle
- 2012: Long-Term System Assessment (LTSA) found potential for large wind generation build out in the Panhandle
- 2013: ERCOT conducted Panhandle Study to identify future transmission upgrade needs in the Panhandle to support continued generation development
 - Regional Planning Group (RPG) held synchronous condenser workshop
 - ERCOT completed study in spring 2014
 - Study found that synchronous condensers and addition of second circuit on the Panhandle “loop” would be the next upgrades
- 2014: DATC proposed synchronous condenser project to RPG
- 2015: PUCT asked ERCOT to perform Panhandle Study
 - PUCT identified second circuit addition as needed under CREZ order
 - Sharyland Utilities submitted project proposal to RPG

ERCOT Independent Review

Study

- 4,304 MW of wind generation expected in Panhandle by the end of 2017
 - Includes existing plants plus those that meet Planning Guide Section 6.9 requirements for inclusion in the planning models as of September 2015
- ERCOT performed reliability (transient stability) and economic congestion analysis

Scenario	Transmission Options	Upgrade Cost Assumption (M\$)	Annual Production Cost Savings / Capital Cost	Pass Economic Criteria (3)?
0	N/A	0	N/A	N/A
1	PH Second Circuit	80	21% (1)	Yes
2	PH Second Circuit + SC(4) at Alibates and Tule Canyon	64.25 (SCs only)	34% (2)	Yes

(1) Compared to Scenario 0

(2) Compared to Scenario 1

(3) Per Protocol Section 3.11.2 (5) the projected annual production cost savings of a project must be greater than or equal to the first year annual revenue requirement of a project which is assumed to be 15% of the capital cost of the project

(4) SC = Synchronous Condenser

ERCOT Recommendation

Conclusions

1. The transmission upgrades will improve system strength and voltage stability in Panhandle.
2. Synchronous Condensers at Alibates and Tule Canyon pass the ERCOT economic planning criteria.
3. The Panhandle second circuit is considered a CREZ project but would also pass the ERCOT economic planning criteria.

ERCOT recommends the Board endorse the following project:

- Synchronous condensers at Alibates and Tule Canyon
 - Each synchronous condenser modeled in this study is based on a generic assumption of a 150 MVA capacity providing 1,050 Ampere (A) of three-phase fault current to the 345 kV system.
- The cost estimate is \$64.25 million.
- TAC voted to endorse the project and to stipulate that the synchronous condensers contemplated in the ERCOT recommendation cannot be used to offer into any competitive market services.

Appendix

Panhandle Transmission Map

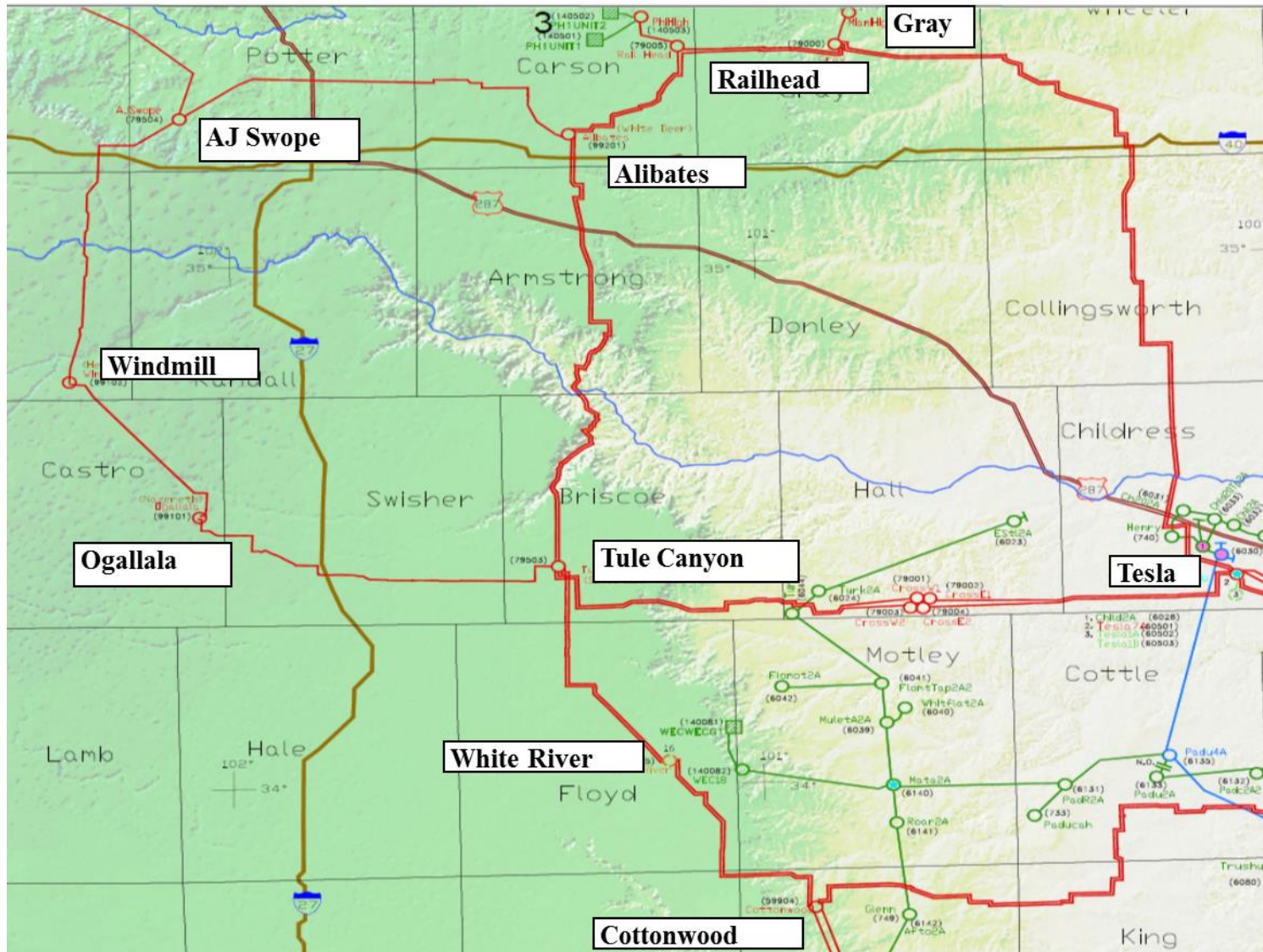

Item 8
ERCOT Public



Date: December 1, 2015
To: Board of Directors
From: Jeff Billo, ERCOT Sr. Manager, Transmission Planning
Subject: Panhandle Regional Planning Group (RPG) Project

Issue for the ERCOT Board of Directors

ERCOT Board of Directors Meeting Date: December 8, 2015

Item No.: 8

Issue:

Whether the Board of Directors (Board) of Electric Reliability Council of Texas, Inc. (ERCOT) should accept the recommendation of ERCOT staff to endorse the need for the Panhandle Regional Planning Group (RPG) Project in order to meet the economic requirements for the ERCOT System, which ERCOT staff has independently reviewed and recommended improvements, and which the Technical Advisory Committee (TAC) has voted to endorse and to stipulate that the synchronous condensers contemplated in the ERCOT recommendation cannot be used to offer into any competitive market services.

Background/History:

The Panhandle region of the ERCOT grid is a prime location for wind generation development. This development is accompanied by potential export limitations due to the operation of wind resources under weak grid conditions as described in the April 2014 Panhandle Renewable Energy Zone Study Report. As of September 9, 2015, 4,304 MW of wind capacity in the Panhandle satisfy the requirements of ERCOT Planning Guide Section 6.9 (PG 6.9), Addition of Proposed Generation Resources to the Planning Models. The total capacity of Panhandle wind resources with a signed interconnection agreement exceeds 7,000 MW, which includes the 4,304 MW that satisfies PG 6.9.

The following independently submitted Regional Planning Group (RPG) proposals identify Panhandle area upgrades to improve system strength and increase Panhandle export limits.

- Duke-American Transmission Company - Phoenix Project.
- Sharyland Utilities - Panhandle Loop Project.

ERCOT performed one combined independent review to identify transmission upgrades that increase Panhandle export limits while meeting the ERCOT economic planning criteria. The installation of a second 345 kV circuit on the Alibates-AJ Swope-Windmill-Ogallala-Tule Canyon transmission line (AAWOTC line) is under the CREZ Order or PURA §39.904(g) per the PUCT Open meeting on September 24, 2015. Based on the result of the independent review, ERCOT concluded that additional transmission upgrades are justified per ERCOT Protocols, Section 3.11.2 as follows.

- Installation of a synchronous condenser connected to the Alibates 345 kV station.
- Installation of a synchronous condenser connected to the Tule Canyon 345 kV station.

The estimated total cost for both synchronous condenser installations is approximately \$64.3 million dollars.



The ERCOT Independent Review of the Panhandle RPG Project is attached as *Attachment A*.

Key Factors Influencing Issue:

- Transmission system improvements that meet economic criteria in the ERCOT System in the Panhandle region.
- The recommended set of improvements will improve the system strength and voltage stability in the Panhandle region.
- TAC voted to endorse the project and to stipulate that the synchronous condensers contemplated in the ERCOT recommendation cannot be used to offer into any competitive market services at its November 19, 2015 meeting.

Conclusion/Recommendation:

ERCOT staff recommends that the Board endorse the Panhandle RPG Project, which ERCOT staff has independently reviewed and recommended improvements, and which TAC has voted to endorse and to stipulate that the synchronous condensers contemplated in the ERCOT recommendation cannot be used to offer into any competitive market services.



ELECTRIC RELIABILITY COUNCIL OF TEXAS, INC.
BOARD OF DIRECTORS RESOLUTION

WHEREAS, after due consideration of the alternatives, the Board of Directors (Board) of Electric Reliability Council of Texas, Inc. (ERCOT) deems it desirable and in the best interest of ERCOT to accept ERCOT staff's recommendation to endorse the Panhandle Regional Planning Group (RPG) Project that meets the economic requirements for the ERCOT System, which ERCOT staff has independently reviewed and recommended improvements, and which the Technical Advisory Committee (TAC) has voted to endorse and to stipulate that the synchronous condensers contemplated in the ERCOT recommendation cannot be used to offer into any competitive market services;

THEREFORE, BE IT RESOLVED, that ERCOT is hereby authorized and approved to endorse the Panhandle RPG Project that meets the economic requirements for the ERCOT System, which ERCOT staff has independently reviewed and recommended improvements, and which TAC has voted to endorse.

CORPORATE SECRETARY'S CERTIFICATE

I, Vickie G. Leady, Assistant General Counsel of ERCOT, do hereby certify that, at its December 8, 2015 meeting, the ERCOT Board passed a motion approving the above Resolution by _____.

IN WITNESS WHEREOF, I have hereunto set my hand this ____ day of December 2015.

Vickie G. Leady
Assistant General Counsel



ERCOT Independent Review of Proposed Panhandle Transmission Upgrades

ERCOT System Planning

Document Revisions

Date	Version	Description	Author(s)
11/03/2015	1.0	Final Draft	John Schmall, Shun-Hsien (Fred) Huang
		Reviewed by	Jeff Billo
11/19/2015	1.1	Add previous study reference	Shun-Hsien (Fred) Huang

TABLE OF CONTENTS

1. Executive Summary	1
2. Introduction.....	2
3. Criteria, Study Assumptions and Methodology	4
3.1 Study Criteria	4
3.2 Study Assumptions and Methodology.....	4
4. Analysis Results.....	8
5. Conclusion and Recommendation.....	9
6. Designated Provider of Transmission Facilities.....	9

1. Executive Summary

Duke-American Transmission Company (Duke) and Sharyland Utilities LP (Sharyland) have submitted Regional Planning Group (RPG) proposals for Panhandle area upgrades to improve system strength and increase Panhandle export limits. For the two RPG proposals submitted, ERCOT has conducted one combined independent review to identify transmission upgrades that increase Panhandle export limits while meeting the ERCOT Protocol economic planning criteria.

The installation of a second 345 kV circuit on the Alibates-AJ Swope-Windmill-Ogallala-Tule Canyon transmission line (AAWOTC line) is under the CREZ Order or Public Utility Regulatory Act (PURA) §39.904(g) as discussed at the Public Utility Commission of Texas' (Commission) Open Meeting on September 24, 2015. Based on the result of the independent review, ERCOT concludes that additional transmission upgrades are justified per ERCOT Protocols, Section 3.11.2 as follows:

- Installation of a synchronous condenser connected to the Alibates 345 kV station.
- Installation of a synchronous condenser connected to the Tule Canyon 345 kV station.

For purposes of this review, each synchronous condenser was assumed to provide typical dynamic response with 150 MVAR of reactive capacity and 1,050 Ampere (A) of three-phase fault current to the 345 kV system. ERCOT recommends that the designated provider for the transmission upgrades consult with ERCOT if different specifications of the synchronous condensers are considered for implementation. The estimated total cost for both synchronous condenser installations is approximately \$64.25 million dollars. The estimate may vary as the designated provider of the new transmission facilities performs more detailed cost analysis.

2. Introduction

The Competitive Renewable Energy Zone (CREZ) transmission improvements were endorsed by the Commission in 2008 in order to accommodate an incremental 11,553 MW of wind generation capacity in west Texas. Also, at the time the Commission ordered the CREZ transmission projects to be constructed there were no generation plants with signed generation interconnection agreements (SGIA) for connection to the proposed Panhandle CREZ transmission facilities. ERCOT, in conjunction with the CREZ Transmission Service Providers (TSPs), commissioned the CREZ Reactive Power Study¹ to identify the size, type, and location of equipment needed to control, condition, and route the power flowing through the CREZ transmission projects. The study was completed in 2010 and the reactive equipment necessary to support the export of power from the Panhandle was implemented for 2,400 MW of wind generation capacity, even though the transmission lines were constructed to accommodate a much larger thermal capacity. This decision was made because the size and location of any additional equipment would be dependent upon the size and location of the wind generation that actually developed in the Panhandle area.

As of 2013, there was over 4 GW of wind generation capacity with SGIAs in the Panhandle and more than 10 GW of additional wind generation capacity progressing through the interconnection process to connect to the Panhandle. Recognizing the potential challenges associated with connecting a large amount of wind generation in the Panhandle, ERCOT initiated the Panhandle Renewable Energy Zone study² in early 2013. When completed in April 2014, the study identified the potential system constraints and transmission upgrade needs for the Panhandle to accommodate wind generation projects that may exceed the existing designed Panhandle export capability.

The Panhandle area, depicted in Figure 2.1, is a prime location for wind generation development. This development is accompanied by potential export limitations due to the operation of wind resources under weak grid conditions as described in the April 2014 Panhandle Renewable Energy Zone Study Report. As of September 9, 2015, 4,304 MW of wind capacity in the Panhandle satisfied the requirements of ERCOT Planning Guide Section 6.9 (PG 6.9), Addition of Proposed Generation Resources to the Planning Models. The total capacity of Panhandle wind resources with SGIAs, including 4,304 MW that satisfy PG 6.9, exceeds 7,000 MW.

In response to the Commission's April 17, 2015 Open Meeting request, ERCOT conducted Panhandle Transfer Capability Analysis³ to evaluate transmission solutions (including reactive equipment) for the Panhandle. Note that the installation of a second 345 kV circuit on the AAWOTC line is under the CREZ Order or PURA §39.904(g) as discussed at the Commission's Open meeting on September 24, 2015.

¹ Available at <http://www.ercot.com/content/news/presentations/2011/CREZ%20Reactive%20Power%20Compensation%20Study.pdf>

² Available at <http://www.ercot.com/content/news/presentations/2014/Panhandle%20Renewable%20Energy%20Zone%20Study%20Report.pdf>

³ See Item 58, ERCOT'S SUBMISSION OF THE PANHANDLE TRANSFER CAPABILITY ANALYSIS, in PUC Project No. 42647, *ERCOT Planning and System Costs Associated with Renewable Resources and New Large DC Ties*.

The two Entities below independently submitted RPG proposals that identify Panhandle area upgrades to improve system strength and increase Panhandle export limits:

- Duke-American Transmission Company - Phoenix Project
- Sharyland Utilities LP - Panhandle Loop Project

For the two RPG proposals submitted, ERCOT has conducted one combined independent review to identify transmission upgrades that increase Panhandle export limits while meeting the ERCOT Protocol economic criteria.

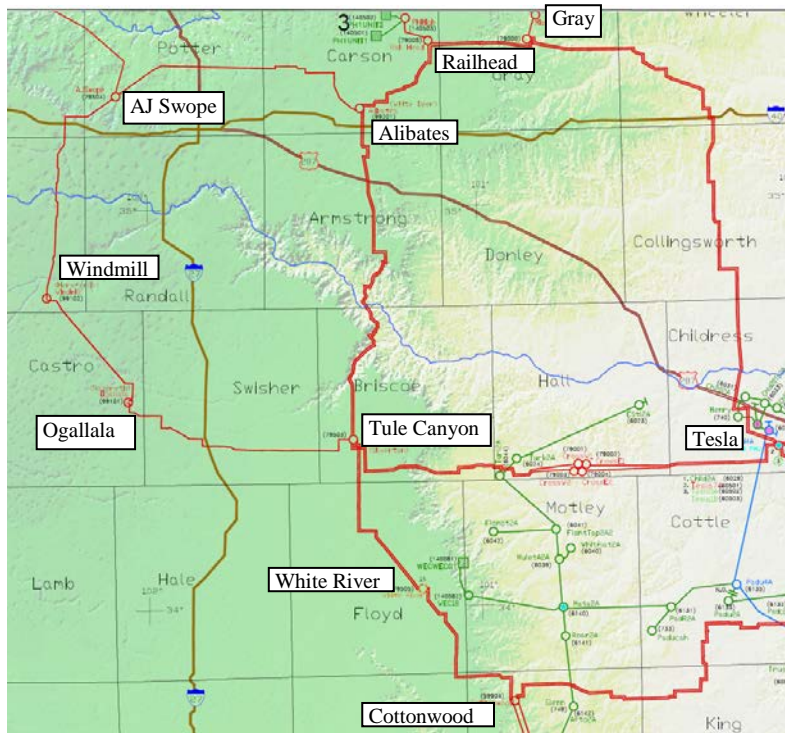

Figure 2.1: Panhandle Area Map

3. Criteria, Study Assumptions and Methodology

ERCOT performed short circuit, reliability and economic analysis to identify and evaluate potential transmission upgrades to increase Panhandle export limits. The study criteria, assumptions and methodology for the ERCOT independent review are described in this section and are consistent with the North American Electric Reliability Corporation (NERC) Reliability Standards, ERCOT Protocols, and ERCOT Planning Guides.

3.1 Study Criteria

The following criteria were applied in this study. Note that short circuit analysis was only used to calculate the weighted short circuit ratio (WSCR) which is considered to be part of the reliability analysis criteria.

Reliability Analysis

- NERC Reliability Standard TPL-001-4 and ERCOT Planning Guide.
- Post dynamic disturbance voltage recovers within the range from 0.9 pu to 1.1 pu.
- Post dynamic disturbance frequency recovers within the range from 59.4 Hz to 60.4 Hz.
- Panhandle System Strength - maintain a WSCR equal to or greater than 1.5 under normal system conditions.

Economic Analysis

- Thermal: 100% rate A for base case and 100% rate B for contingency analysis.
- Interface: 90% of identified reliability limit for consistency with typical real-time implementation.
- Economic Criterion: The annual production cost savings of a transmission project must be greater than or equal to the first year annual revenue requirement for the transmission project. The first year annual revenue requirement for a transmission project is assumed to be 15% of the estimated capital cost of the project.

3.2 Study Assumptions and Methodology

3.2.1 Study Base Case

The Dynamics Working Group (DWG) 2016 High Wind Low Load (HWLL) case was used as the starting base case for the reliability analysis. The collector systems and dynamic models provided by the Resource Entities through Resource Asset Registration Forms (RARFs) or Full Interconnection Study (FIS) stability reports were used to represent Panhandle wind generation projects. This study considered all Panhandle generation projects that satisfy the requirements of PG 6.9 as of September 9, 2015. Table 3.1 includes a summary of wind generation capacity that satisfies PG 6.9 connected to each Panhandle transmission network station. Conventional generation resources in west Texas, including Oklaunion, Permian Basin, Antelope/Elk, and Morgan Creek were de-committed to simulate the most stressed system condition from a voltage stability and system strength perspective. All of the CREZ series capacitors were modeled in-

service except for Rocky Mound⁴. When simulating Panhandle output at less than full capacity (to identify reliability limits), the output of all Panhandle resources was proportionally reduced.

The 2017 UPLAN case from the 2014 Regional Transmission Plan⁵ was used as the starting base case for economic analysis to identify the Panhandle annual generation output, curtailment if any, and annual production costs for the entire ERCOT Region. A System Protection Working Group (SPWG) 2016 case was used as the starting base case for short circuit analysis. Case modifications and assumptions applied for the economic and short circuit analyses were consistent with those applied for the reliability analysis (as identified above).

Table 3.1: Panhandle Wind Generation by Transmission Station

Panhandle Transmission Station	Wind Generation Capacity (MW)
Cottonwood	299.25
White River	701.6
Tule Canyon	509.85
Ogallala	299.48
Windmill	499.6
AJ Swope	354.95
Alibates	751.44
Railhead	400
Gray	488.6
Tesla	0
TOTAL	4304.77

3.2.2 Study Methodology

Because system reliability can be maintained by managing the output of Panhandle Wind Generation Resources, the purpose of this independent review is to determine whether transmission reinforcements can be justified based on ERCOT economic criteria. Based on the submitted RPG proposals and previous analysis referenced above, maintaining a WSCR greater than or equal to 1.5 is identified as the limiting constraint. Therefore, the Panhandle output limit based on the WSCR calculation was determined for various upgrade scenarios by proportionally reducing the output with respect to the capacity of all Panhandle Wind Generation Resources. Then, economic analysis identified the annual production cost savings relative to the capital cost of the transmission upgrade. Finally, dynamic simulations were performed to confirm that no reliability violations were observed for conditions where Panhandle wind generation output was at least as high as the WSCR Panhandle export limit.

The WSCR is an index based on short circuit levels for the strength of a cluster of buses where inverter-based resources are connected to the system. The determination of these buses in the Panhandle (effectively, the Panhandle interface) is based on short circuit analysis to identify a

⁴ See Item 600, Joint Notification of CREZ Project Update, in PUC Project No. 38517 in which ERCOT and Oncor Electric Delivery Company LLC (Onco) notified the Commission that the Rocky Mound reactive compensation project is on-hold until further notice to permit additional study of SSO in ERCOT.

⁵ http://www.ercot.com/content/news/presentations/2015/2014_Regional_Transmission_Plan_public.zip

“weak grid” boundary between weaker network buses and stronger network buses. If generation output in the Panhandle were to be high such that the WSCR were to fall below 1.5, it could lead to control system instability in the Panhandle under contingency conditions.

Figure 3.1 shows the contour map with a one-line diagram of the Panhandle transmission system based on three-phase to ground short circuit current level calculated at each bus. The short circuit current level shown in Figure 3.1 is in per unit at base of 10 kA. The short circuit levels at Tesla and Cottonwood are less than 30% greater than the short circuit level at Tule Canyon, while the short circuit levels at Riley, Edith Clarke and Dermott are all more than 70% greater than the short circuit level at Tule Canyon. This significant difference in short circuit levels suggests that generation resources connected at Riley, Edith Clarke and Dermott would not share Panhandle system strength challenges. Therefore, the following 345 kV transmission paths, shown as black dashed lines in Figure 3.1, define the Panhandle interface.

- Tesla-Riley/Jim Treece (double circuits)
- Tesla-Edith Clarke (double circuits)
- Cottonwood-Edith Clarke (double circuits)
- Cottonwood-Dermott (double circuits)

All generation that is delivered to the ERCOT system through this interface is considered Panhandle generation.

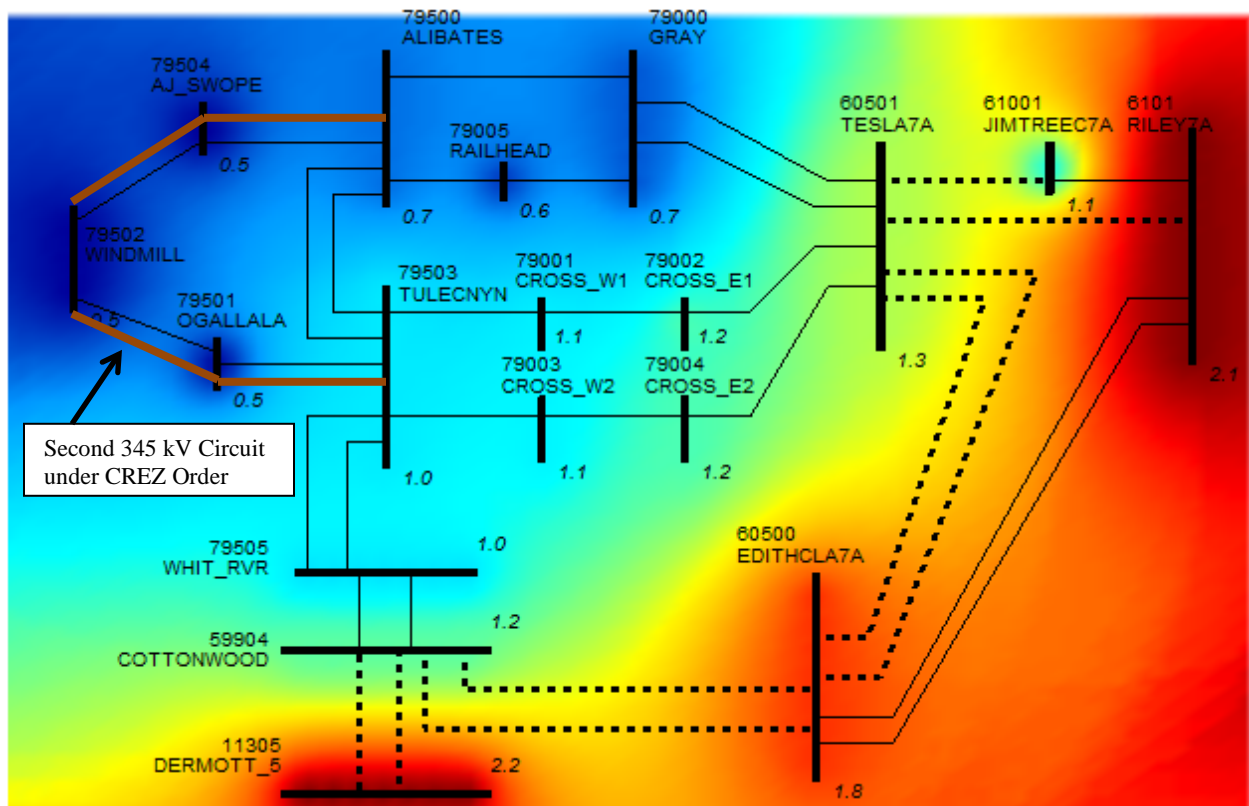

Figure 3.1: Panhandle Transmission System and Interface

3.2.3 Tools

ERCOT utilized the following software tools for the independent review of Panhandle transmission upgrades:

- PSS/e version 32 was used for reliability analysis (short circuit calculations and dynamic simulations)
- UPLAN version 9.0.4.13941 was used to perform security-constrained production cost analysis

3.2.4 Contingencies

As noted above, reliability analysis was performed with conventional generation resources in west Texas de-committed to simulate the most stressed system condition from a voltage stability and system strength perspective. Additionally, a set of 210 contingencies were tested including the loss of single or double circuit lines following a three-phase fault with normal clearing and breaker failure events following a single-line-to-ground fault.

4. Analysis Results

Based on the submitted RPG proposals and previous analysis referenced above, the primary transmission upgrades considered for this review were the AAWOTC line and synchronous condenser installations. Numerous dynamic simulations indicate that installing synchronous condensers at Alibates and Tule Canyon are preferred at this time over other Panhandle locations such as Gray, Windmill, Ogallala, or Cottonwood due to better performance with respect to voltage support and transient response while also providing the required system strength support to maintain a WSCR of 1.5.

Economic analysis was performed by incorporating a Panhandle interface export limit in the base case, increasing the export limit in the transmission upgrade change case, and then comparing the production cost simulation results between the base case and the change case. The transmission upgrade cost estimates were taken from the Sharyland Panhandle Loop Project RPG submittal.

The results, which are summarized in Table 4.1, indicate that installation of the AAWOTC line satisfies the ERCOT economic criteria with annual production cost savings exceeding 15% of the capital cost of the line. Since the AAWOTC line is under the CREZ Order as discussed at the Commission’s Open Meeting on September 24, 2015, economic analysis of the synchronous condenser installations was performed assuming that the AAWOTC line was already installed. Table 4.1 shows that the synchronous condenser installations also satisfy the ERCOT economic criteria. The synchronous condensers modeled in this study (at Alibates and Tule Canyon) were based on a generic assumption of a 150 MVar capacity providing 1,050 Ampere (A) of three-phase fault current to the 345 kV system.

Table 4.1: Economic Analysis Results for 4,304 MW of Panhandle Wind Capacity

Panhandle Wind Capacity (MW)	Transmission Upgrade	Upgrade Cost Assumption (M\$)	Panhandle Export Limit (MW) ⁽¹⁾	Panhandle Operation Export Limit (MW) ⁽²⁾	Annual Production Cost Savings/ Capital Cost
4,304	None	0	3,012	2,711	N/A
4,304	AAWOTC Line	80	3,233	2,910	21% ⁽³⁾
4,304	Synchronous Condensers	64.25 ⁽⁵⁾	3,702	3,332	34% ⁽⁴⁾

Notes:

(1) Determined by WSCR = 1.5, which is the most binding constraint

(2) 90% of export limit identified in (1)

(3) Compared to scenario with no transmission upgrades

(4) Compared to scenario with AAWOTC line

(5) Reflects the estimated installation cost for synchronous condensers only

Acceptable reliability performance for 4,304 MW of Panhandle wind capacity was confirmed with dynamic simulation for each transmission upgrade scenario and associated Panhandle export limit.

5. Conclusion and Recommendation

ERCOT identified an economic justification per ERCOT Protocols Section 3.11.2 for transmission upgrades to increase Panhandle exports. While the installation of the AAWOTC line satisfies the ERCOT economic criteria, the project does not require ERCOT Board endorsement since the project is under the CREZ Order as discussed at the Commission's Open Meeting on September 24, 2015. Additional transmission upgrades are recommended as follows:

- Installation of a synchronous condenser connected to the Alibates 345 kV station.
- Installation of a synchronous condenser connected to the Tule Canyon 345 kV station.
- For purposes of this review, each synchronous condenser was assumed to provide typical dynamic response with 150 MVAR of reactive capacity and 1,050 Ampere (A) of three-phase fault current to the 345 kV system. ERCOT recommends that the designated provider for the transmission upgrades consult with ERCOT if different specifications of the synchronous condensers are considered for implementation.
- The estimated total cost for both synchronous condenser installations is approximately \$64.25 million dollars. The estimate may vary as the designated provider of the new transmission facilities performs more detailed cost analysis.

6. Designated Provider of Transmission Facilities

In accordance with ERCOT Protocols Section 3.11.4.8, ERCOT is to designate TSPs for projects reviewed in the RPG. The default providers will be those that own the end points of the new projects. These providers can agree to provide or delegate the new facilities or inform ERCOT if they do not elect to provide them. If different providers own the two ends of the recommended projects, ERCOT will designate them as co-providers and they can decide between themselves what parts of the recommended projects they will each provide.

Sharyland owns the connection points for the recommended synchronous condenser installations. Therefore, ERCOT designates Sharyland as the designated transmission provider of the synchronous condensers at both Tule Canyon and Alibates.