

Real-Time Overview



Topic Outline

- I. Description and timeline for Real-time activities**
- II. Overview of System Implementation**

Presentation Objective

Using the information in this presentation...

...you will be able to understand

- Timeline and processes of the Operating Period
- Inputs and outputs related to Real-Time Operations
- Load Frequency Control process
- Ancillary Service deployments



I. Description and Timeline for Real-Time Activities

Real-Time Operations

The Operating Period Activity Timeline

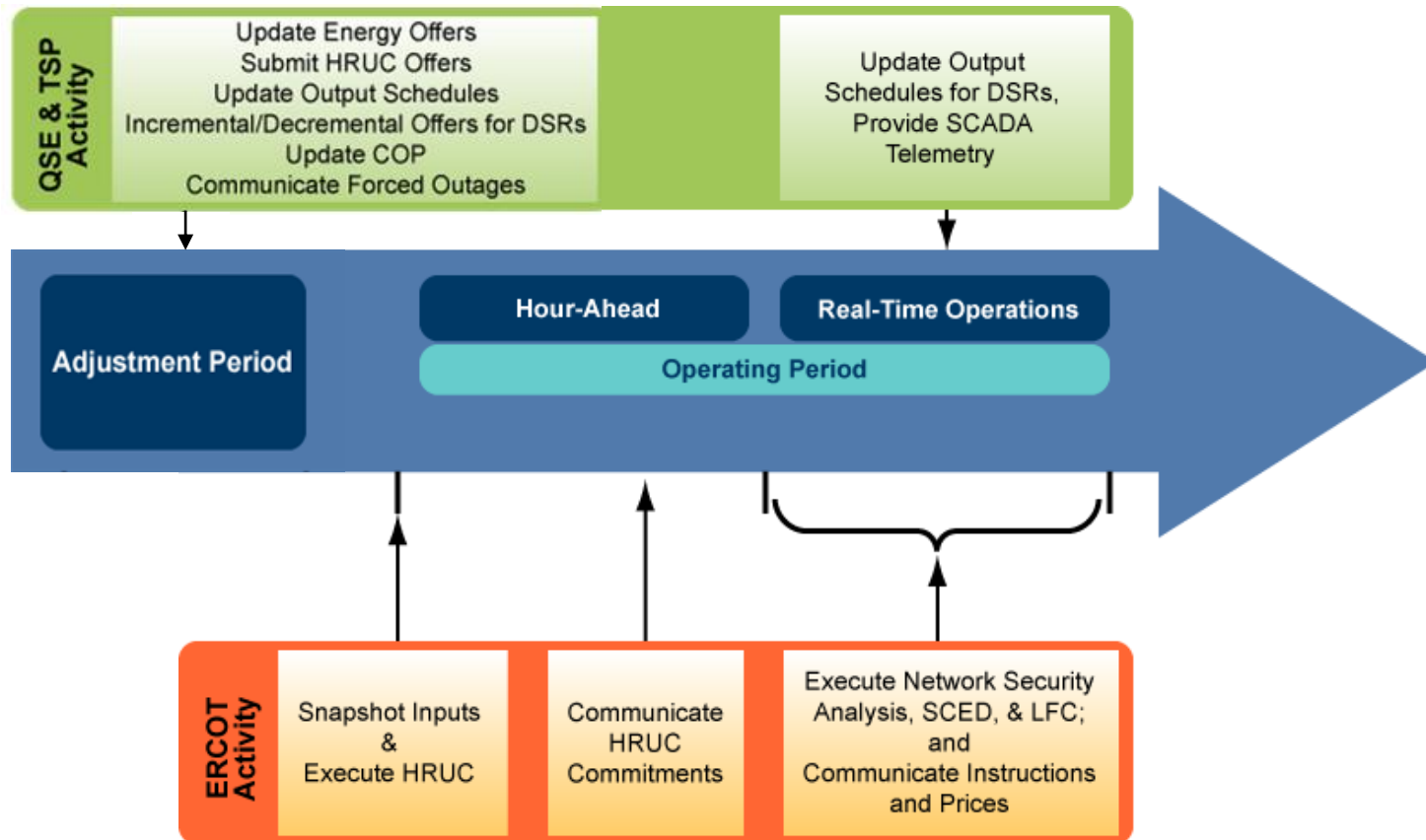

Real-Time Operations

Energy Dispatch

Real-Time Operations balances reliability and economics.

During Real-Time Operations, ERCOT will simultaneously:

- Achieve power balance (minimizing the use of Regulation Service).
- Manage congestion while operating within the constraints of the system at least-cost dispatch.

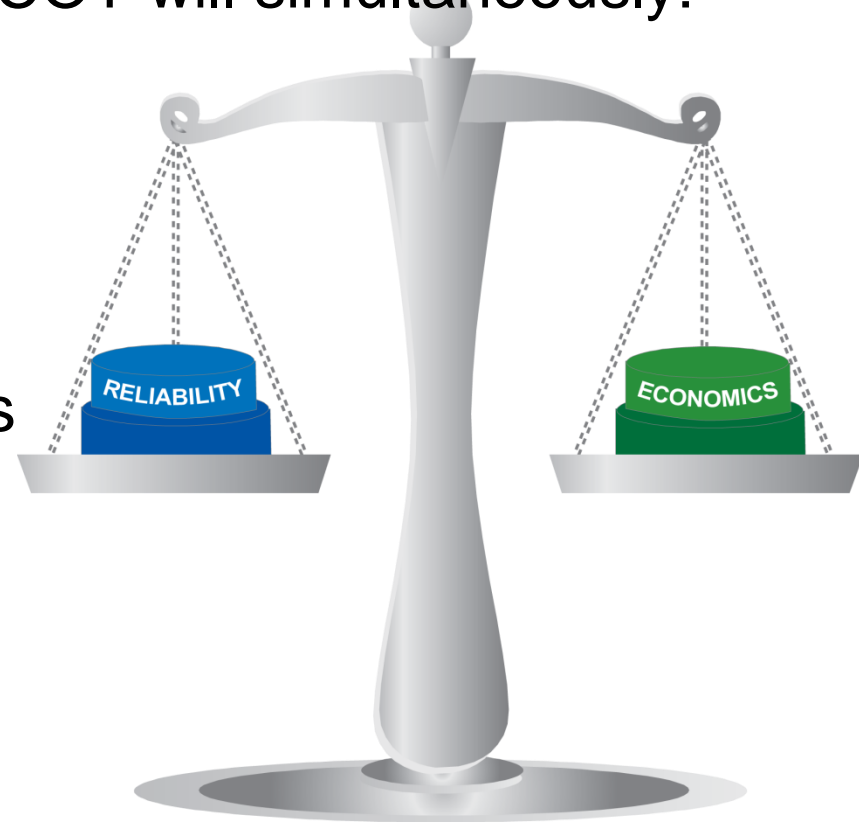

Energy Dispatch

Energy Dispatch

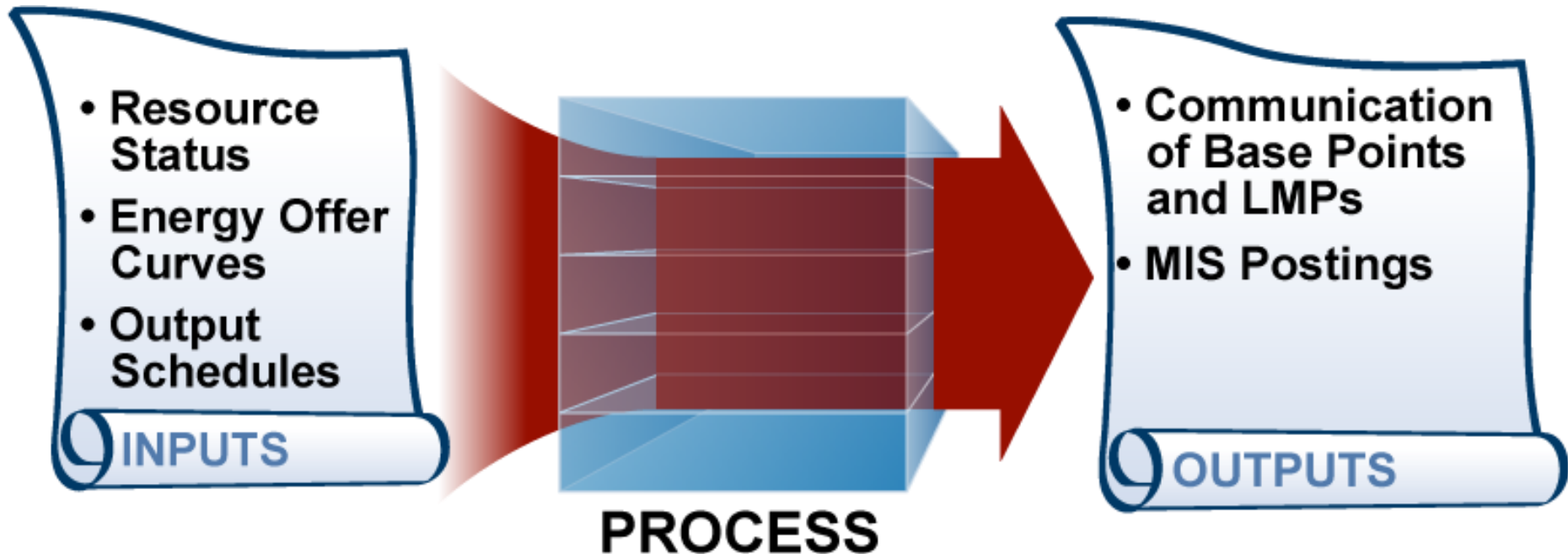

Security Constraint Economic Dispatch Inputs

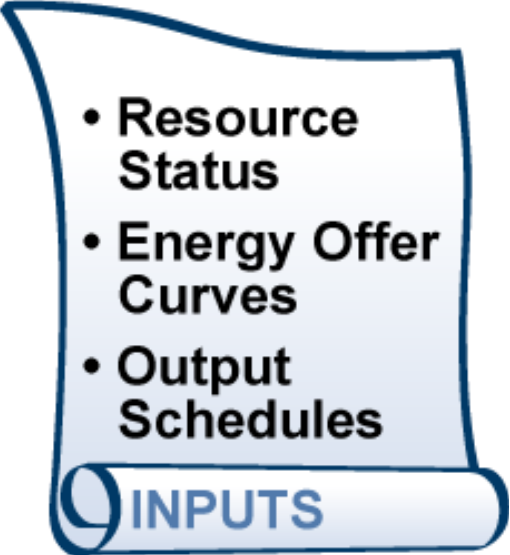
- 
- **Resource Status**
 - **Energy Offer Curves**
 - **Output Schedules**

INPUTS

Telemetry...

- **Resource Status** is communicated via real-time telemetry
- **Resource Limits** are calculated using the real-time telemetered MW consumption and Ancillary Service schedules

Offers available to SCED...

- **Energy Offer Curve** represents the QSE's offer to sell energy at or above a certain price and at a certain quantity for an On-Line Resource (\$) (MW)
- **Output Schedule** - QSE's desired MW level for a Resource for every five-minute interval (MW)
- **Incremental / Decremental Curve**

Energy Dispatch Inputs

QSE Data to ERCOT

Telemetered Data includes:

- Generation Resource
 - Real net and reactive power output
 - High and Low Sustained Limits
- Load Resource
 - Real power consumption
 - Low and Maximum Power Consumption limits

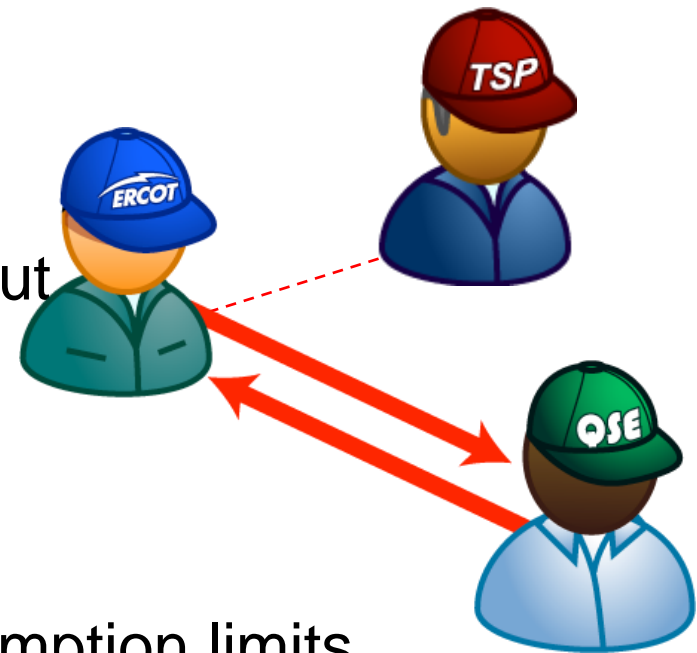

Energy Dispatch Inputs

QSE Data to ERCOT

Telemetered Data (continued):

- Resource breaker switch status
- Ancillary Service Resource Responsibility
- Ancillary Service Schedule
- Current configuration of combined-cycle Resources

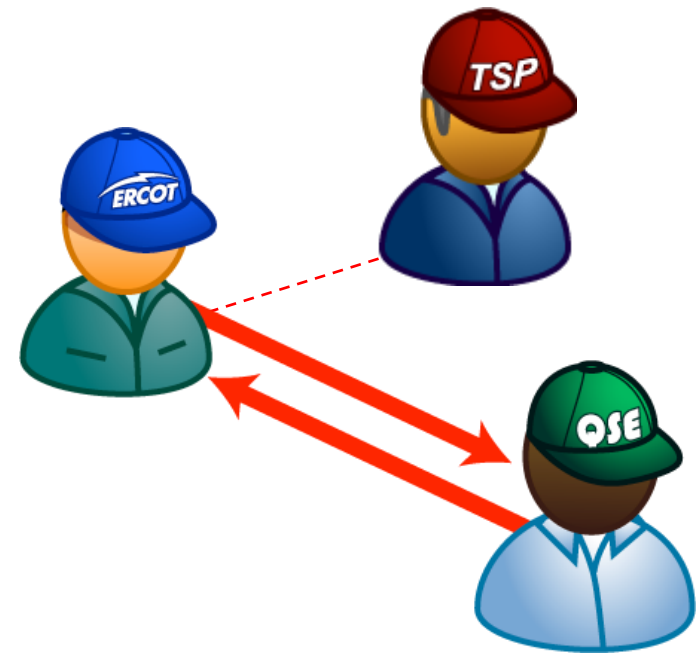

Energy Offer Curve

Proxy Curve-Extension to LSL and HSL

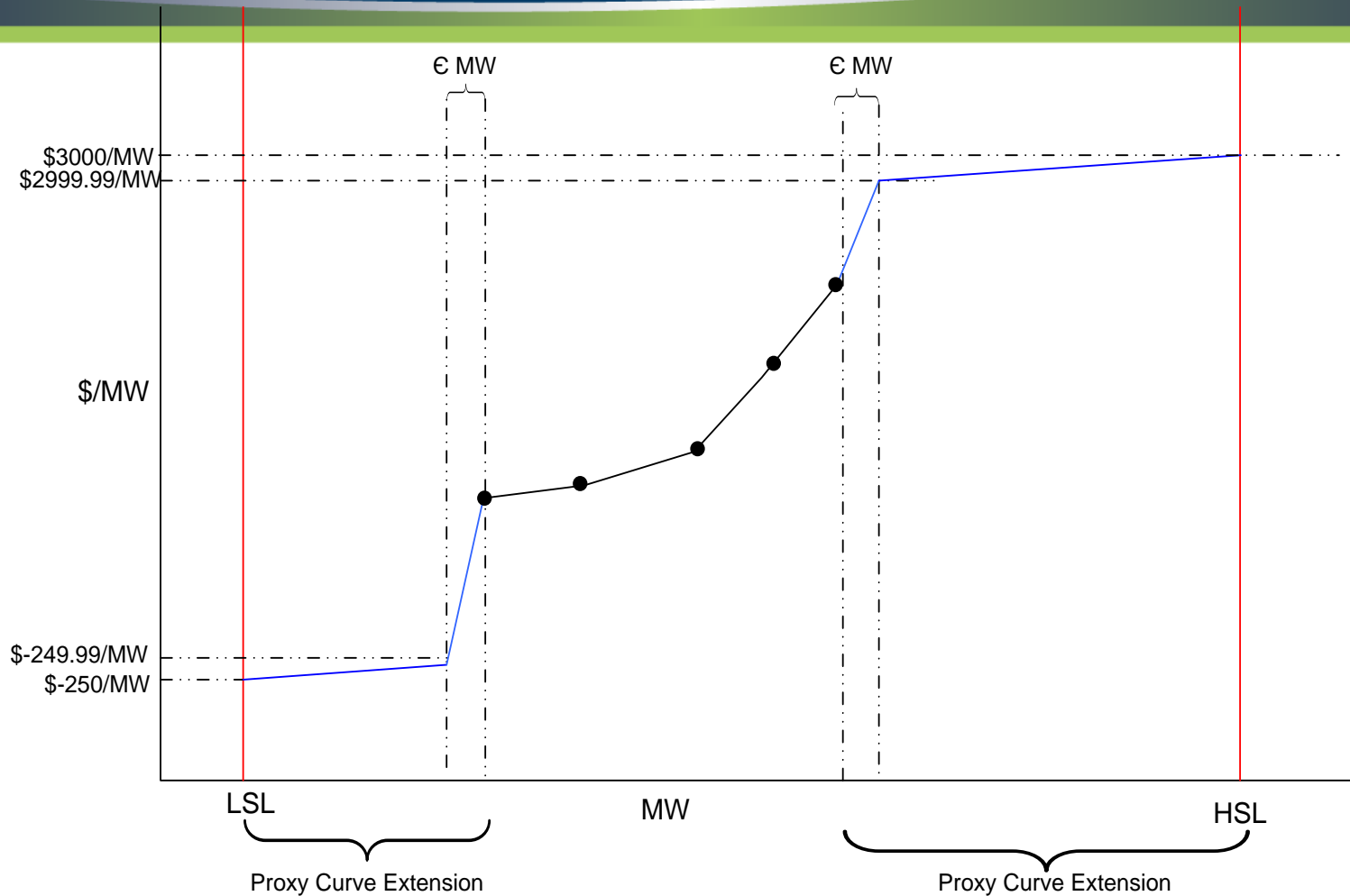

Output Schedule (for non-Wind Resources) Proxy Curve-Extension to LSL and HSL

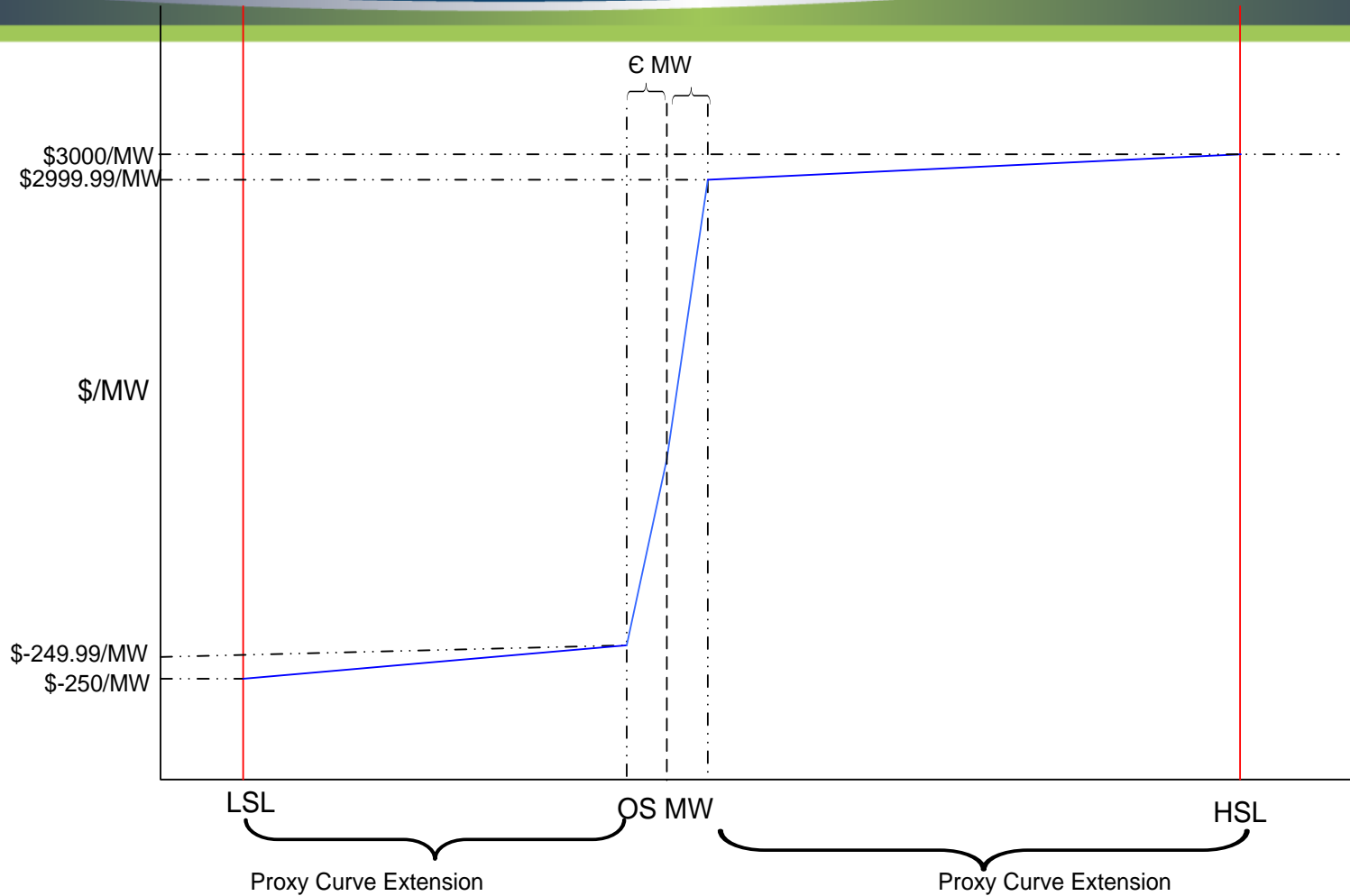

Energy Dispatch Inputs

Reminder of COP importance

ERCOT uses telemetry to automatically gather important QSE resource information. However, QSEs are still responsible for updating their Current Operating Plan (COP).

- The COP must also be updated for any affected intervals or operating periods.



Energy Dispatch Inputs

Requesting Resource Decommittments

For self-committed units:

To start the process, the QSE verbally/COP requests that ERCOT decommit a Resource.

- Request can be made for any Interval that is not RUC-committed.



Energy Dispatch Inputs

Requesting Resource Decommitments (continued)

ERCOT then performs HRUC study to determine if ERCOT will remain reliable at n-1 with that Resource Off-Line.



ERCOT grants request if analysis indicates the Resource Outage contingency results in no additional active constraints for SCED



ERCOT denies requests that impact reliability
- becomes RUC_committed

Energy Dispatch Inputs

Communicating Forced Outages

In the event of an outage, the telemetered status of the Resource automatically notifies ERCOT of a Forced Outage. Additionally, the QSE provides ERCOT with:

- Time of expected change in Resource Status or rating
- The nature of the Forced Outage or de-rating
- Expected minimum and maximum duration of the Forced Outage or de-rating

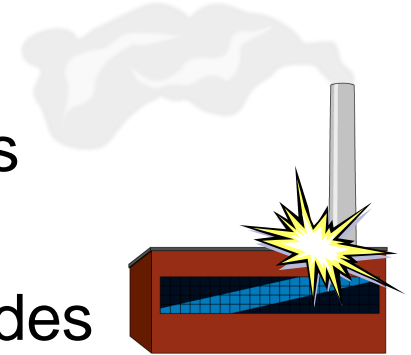

Real-Time Operations

Energy Dispatch Overview

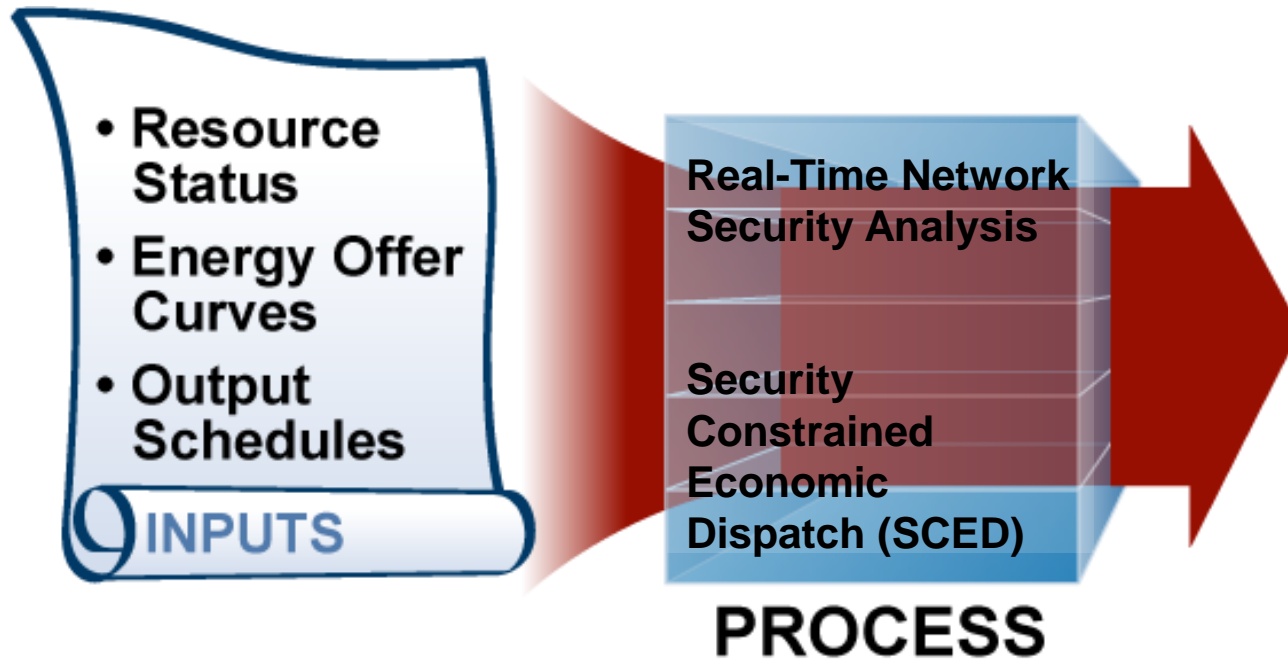

Real-Time Network Security Analysis

Real-Time Network Security Analysis

- Monitors Transmission Elements for limit violations

Outputs:

- List of security violations

Impact:

- SCED will determine Resource dispatch based on security violations.

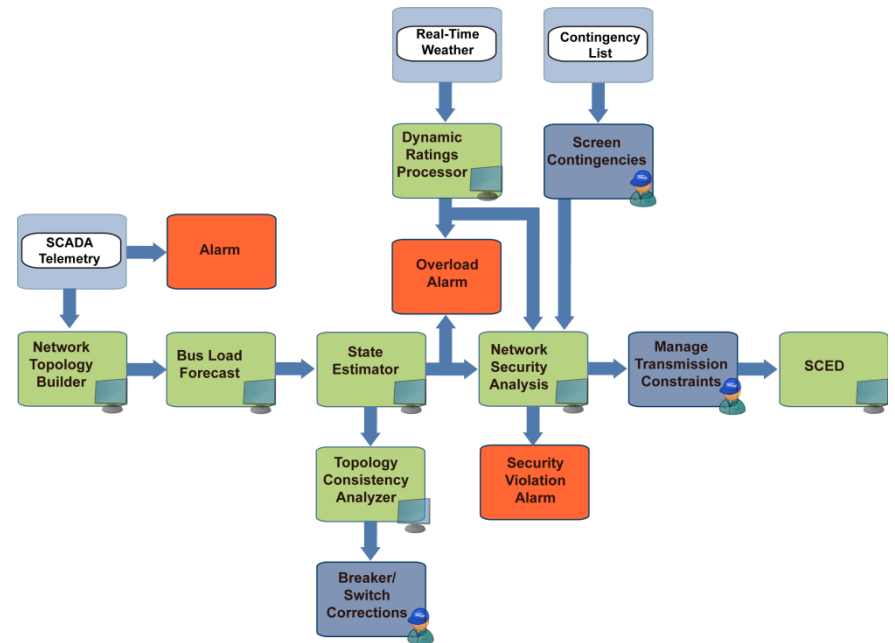

Real-Time Network Security Analysis

Contingencies

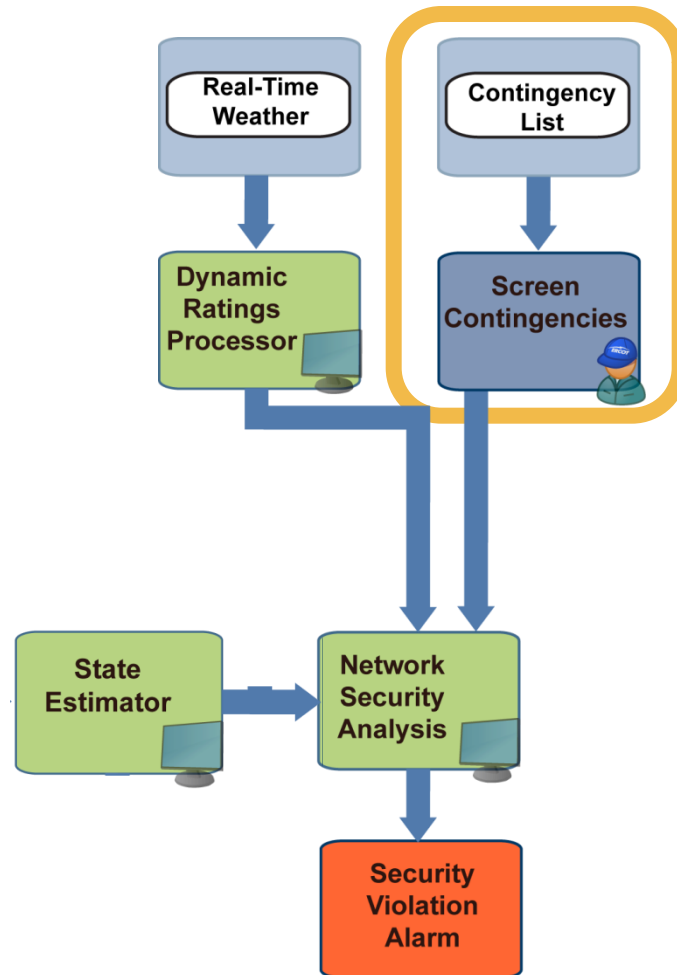

Contingencies are assessed and then compiled for input into the Network Security Analysis.

Real-Time Network Security Analysis

Contingencies

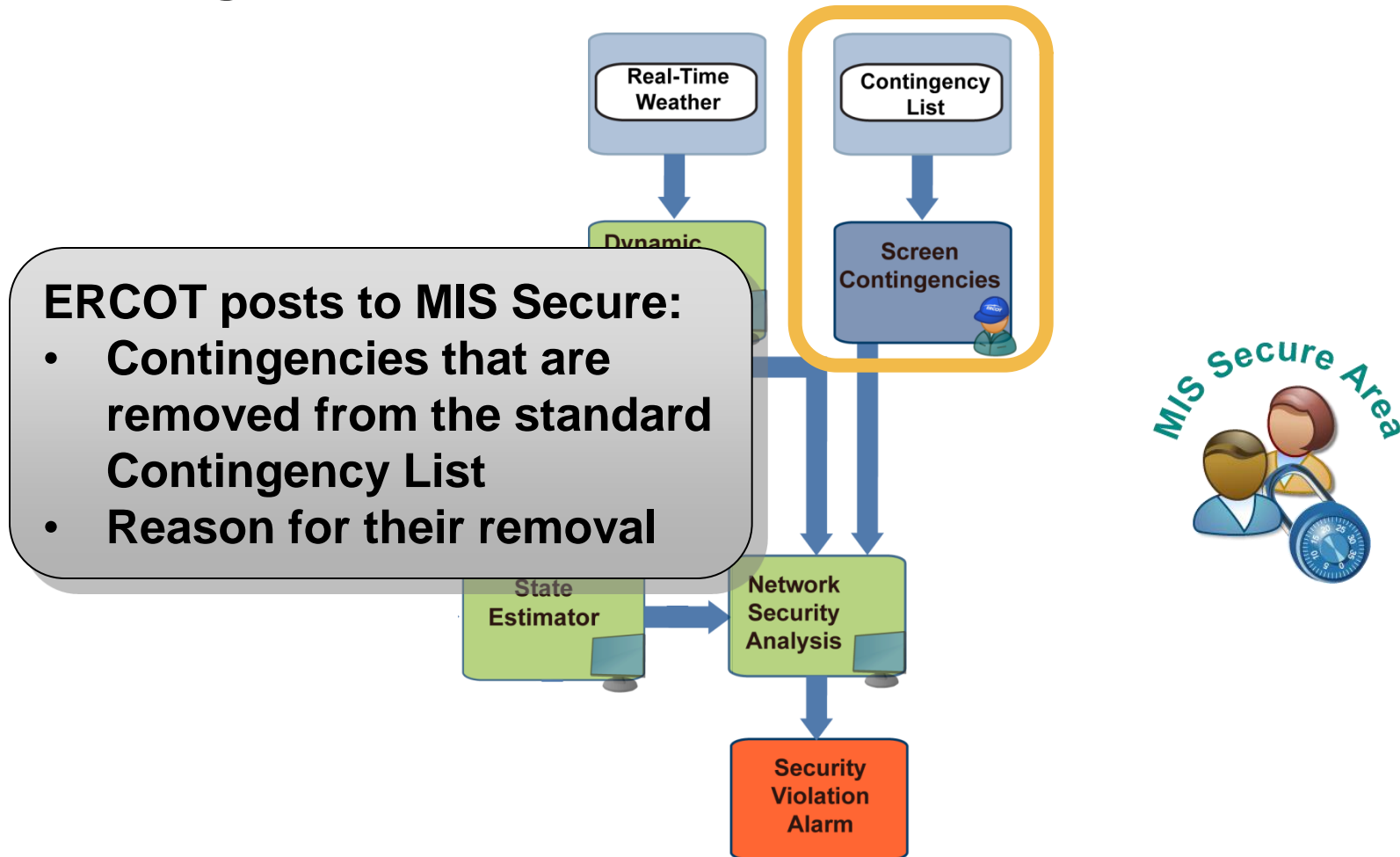

Real-Time Network Security Analysis

Real-Time Network Security Analysis Summary

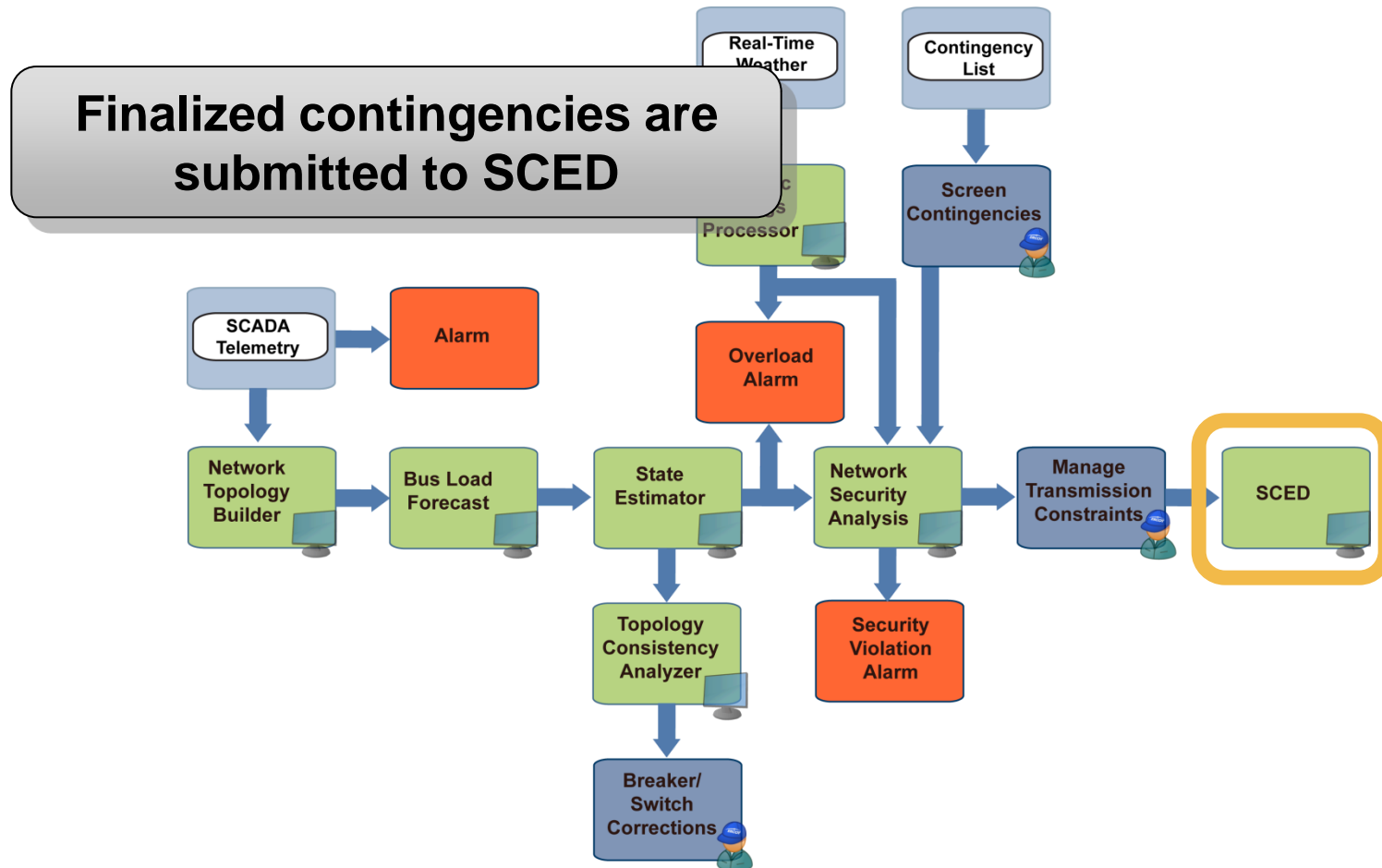

Balancing Reliability and Economics

**Network
Security
Analysis**



**Energy
Offer
Curves**

SCED

Nodal SCED vs Zonal SPD (Real-Time Markets)

	SPD (zonal)	SCED (nodal)
Bids (Offer)	UBES, DBES	Energy Offer Curves, Output Schedules
Interval	15 min	Approx. 5 min
Load Forecast?	Yes	No (GTBD)
No. of Steps	3	2
Solution	Zonal MCPES, QSE Balancing Energy Awards	LMP, Base Points
Dispatch	Portfolio UBES, DBES	Resource Specific
Congestion Management	Zonal (Directly Assigned) and Local (Uplifted)	Locational (Directly assigned)

Two Steps in SCED

Step One:

- Uses the Energy Offer Curves for all On-Line Generation Resources
- Observes the line limits of the Competitive Constraints only
 - Non-Competitive Constraints are ignored
- Determines “Reference LMPs”

Step Two:

- Observes limits of both Competitive Constraints and Non-Competitive Constraints
 - Offer curves are capped at the greater of the Reference LMP or the Mitigated Offer Cap and bounded at the lesser of the Reference LMP or the Mitigated offer floor

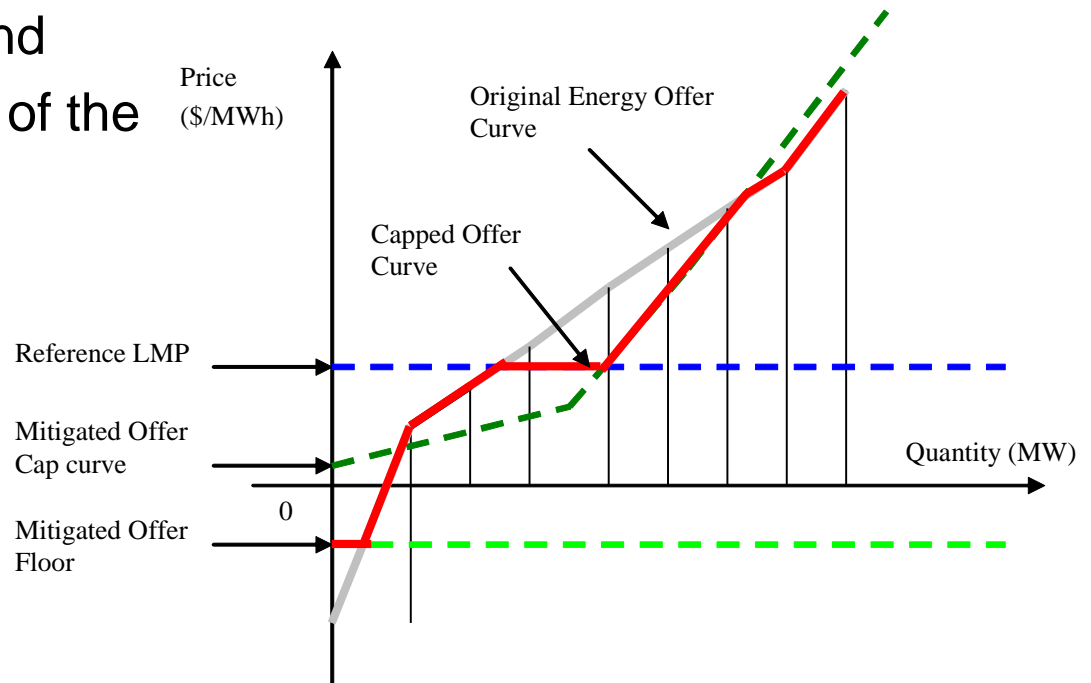

SCED

The SCED Process

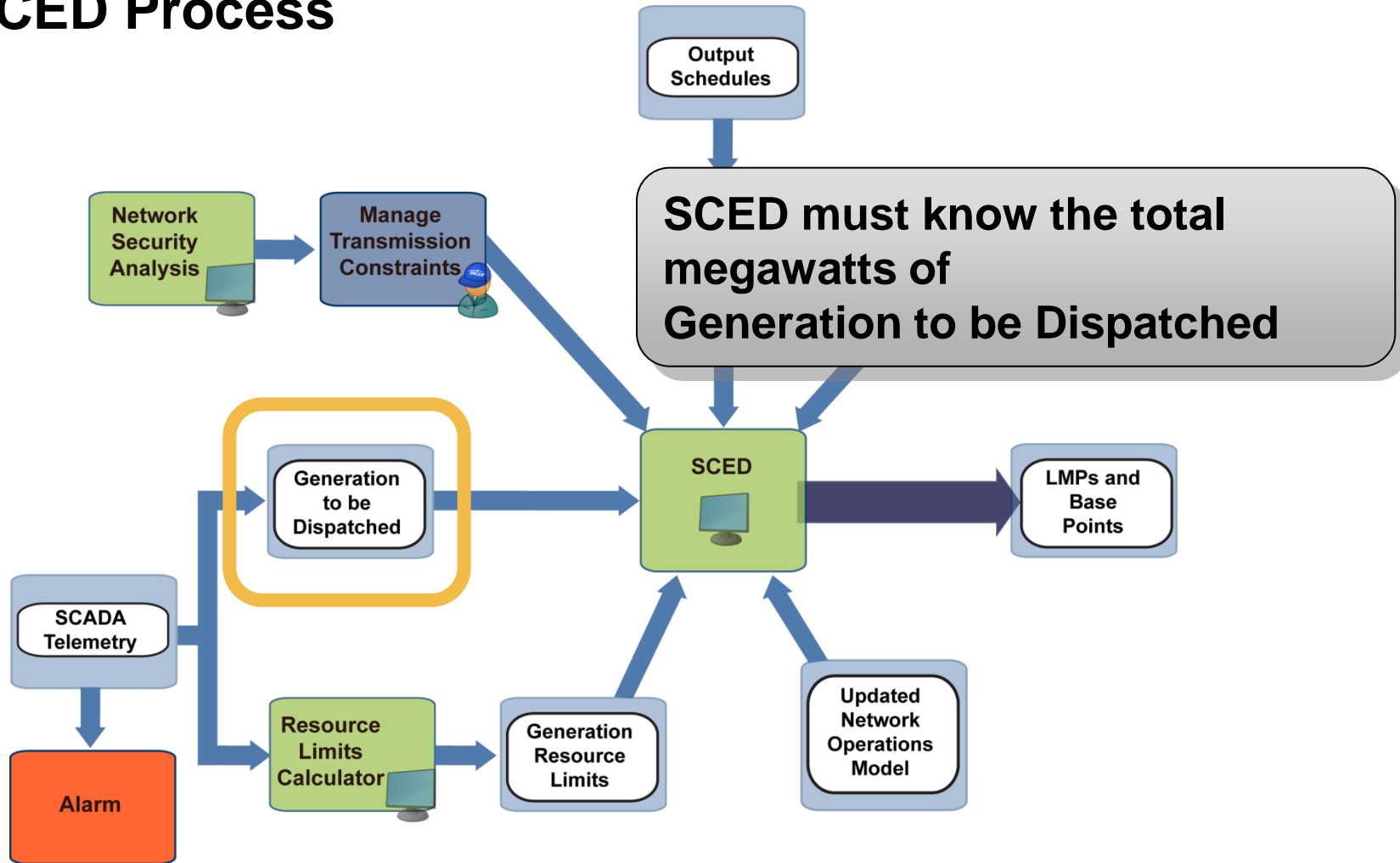

SCED

SCED Timeline

SCED is executed:

- At minimum, every five minutes (not on clock time)
- May be initiated more often by an ERCOT operator or other ERCOT systems.

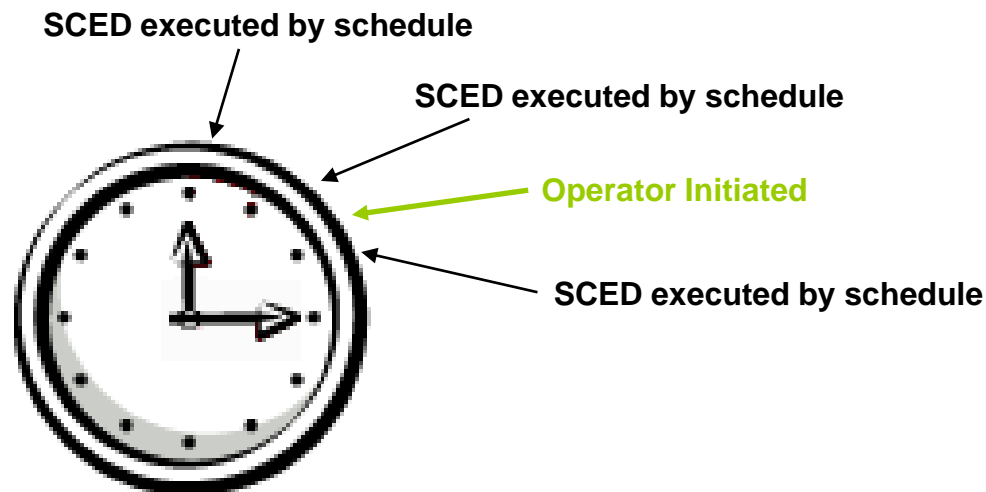

LMPs and Resource Specific Base Points

SCED will produce:

LMPs

- Offer-based marginal cost of serving the next increment of Load at an Electrical Bus

Resource-Specific Base Points

- The MW output level for a Resource produced by the SCED process.

Resource Specific Base Points

When SCED issues Energy Dispatch instructions to QSEs, the information will include:

- Resource Name
- MW level of energy for Generation Resources
 - Includes energy as well as AS dispatch

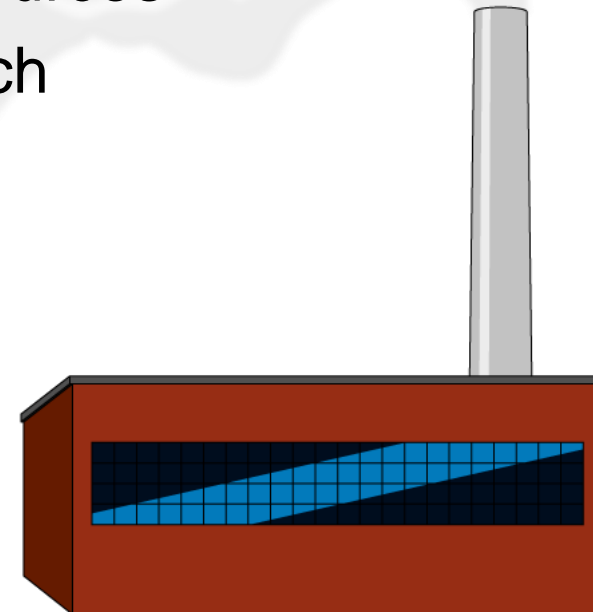

Energy Dispatch Outputs

Energy Dispatch Outputs Overview

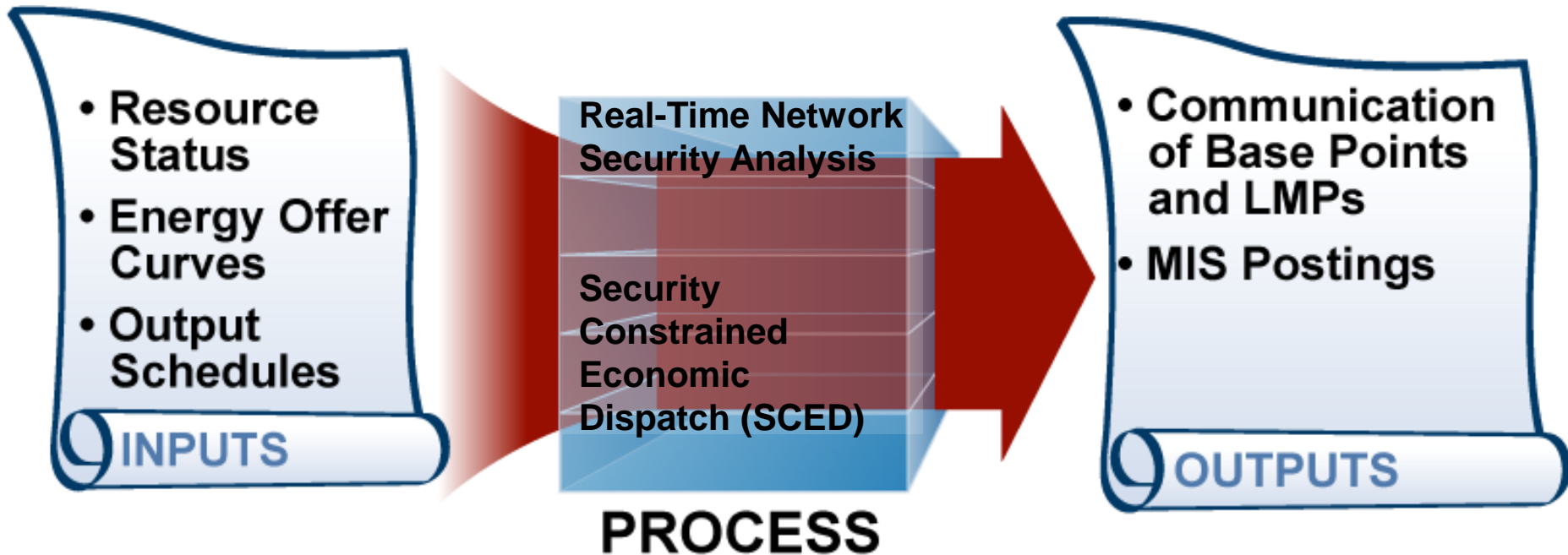

Energy Dispatch Outputs

MIS Postings After SCED

Upon completion of an execution of SCED, ERCOT posts:

- LMPs for each Electrical Bus
- SCED Shadow Prices
- Settlement Point Prices for each Settlement Point immediately following the end of each Settlement Interval
- Active Binding Transmission Constraint by Transmission Element name
- Nodal MIS is active <https://mis.ercot.com/pps/tibco/mis/>

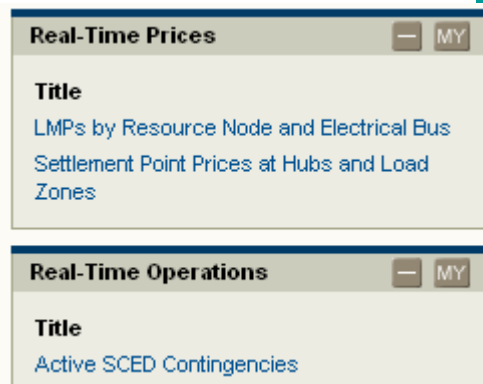

Energy Dispatch Outputs

MIS Hourly Postings

At the beginning of each hour, ERCOT will post:

- Changes in ERCOT system conditions
- Updated system load forecasts and distribution factors
- Total ERCOT System Demand for each Settlement Interval



Load Frequency Control

Load Frequency Control Overview

- Maintains system frequency
- Provides a control signal to each QSE
 - Every 4 seconds
 - Regulation
 - Responsive Reserve

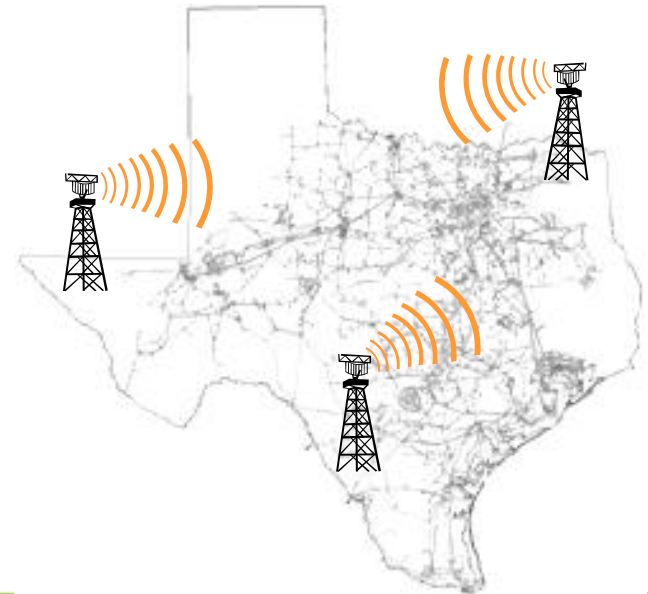

Load Frequency Control

Load Frequency Control Overview

In a 15-minute Interval, SCED is executed 3 times.

In a 15-minute Interval, LFC is executed at least 225 times.

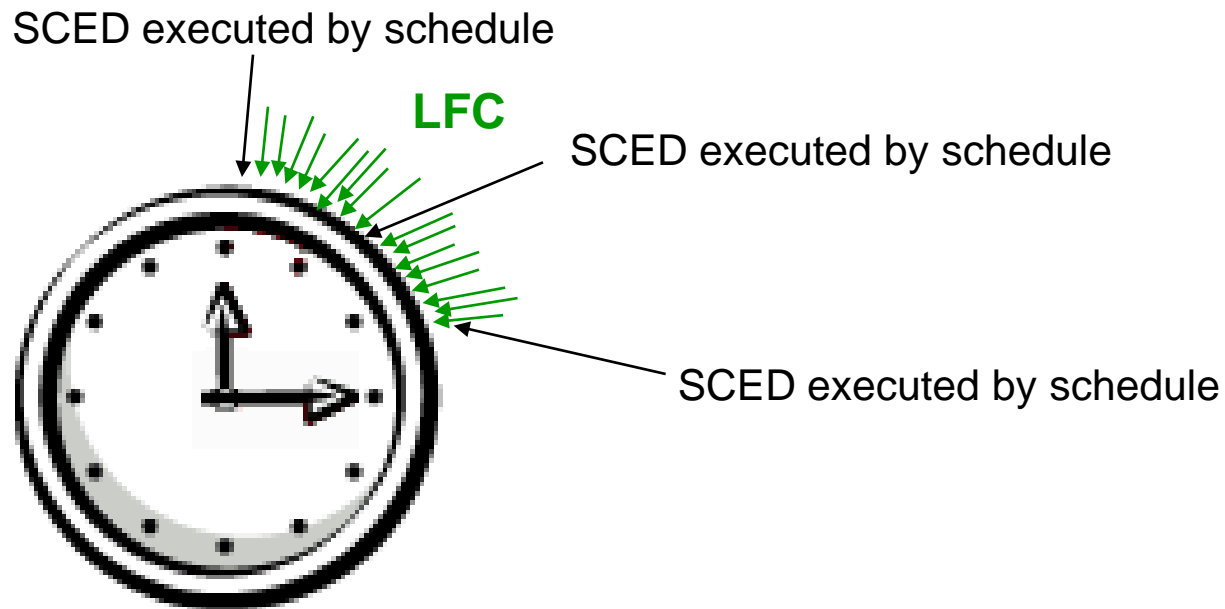

Load Frequency Control

Load Frequency Control Outputs

LFC produces several critical outputs.

- The MW correction needed to return system frequency to scheduled frequency
- Deployment of Resources that provide:
 - Up Regulation (Reg-Up)
 - Down Regulation (Reg-Down)
- Updated Desired Base Point

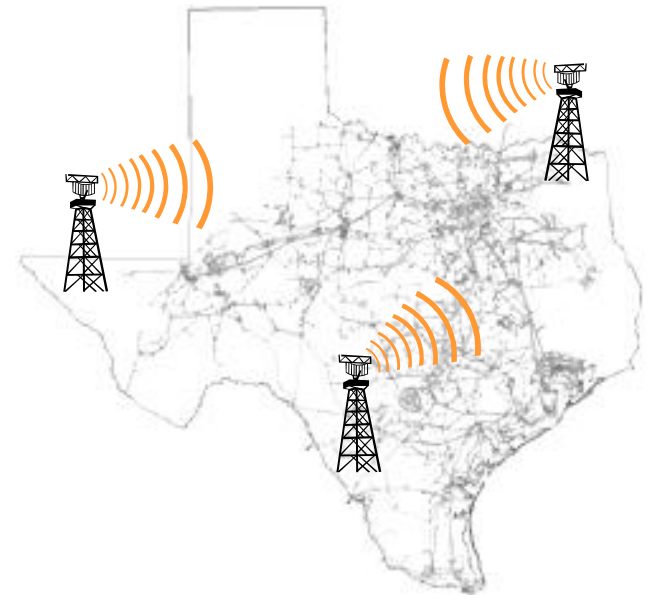

Load Frequency Control

Load Frequency Control Outputs



Posted on MIS Secure Area:.

- Total amount of deployed Reg-Up and Reg-Down energy in each Settlement Interval from the previous day.

Settlement:

- Net energy for a 15-min settlement interval is captured in the Resource's metered generation.
- Net Energy paid at the Real-Time Settlement Point Price.

Ancillary Services

Voltage Support

Regulation

Responsive Reserve

Non Spin



Voltage Support Service

What is Voltage Support Service Dispatch?

- Maintains transmission and distribution voltages within acceptable limits.
- Required by any on-line resource above 20 MVA



Voltage Support Service

Voltage Support Service Dispatch

Unpaid Service

- Online Resource provides VSS up to Unit Reactive Limit.

Paid Services

- Online Resource provides VSS beyond Unit Reactive Limit.
- Online Resources reduce real power output to provide additional reactive power.

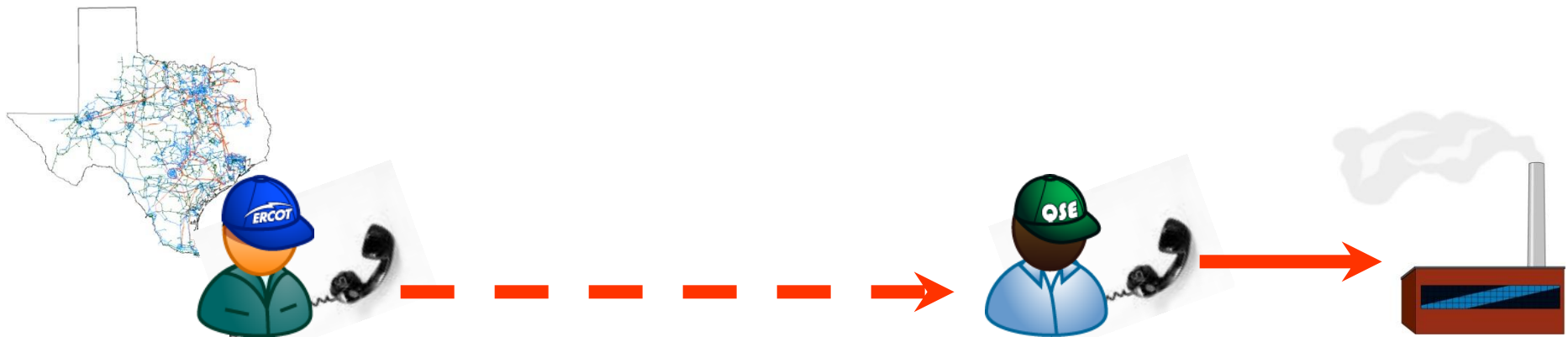

Regulation Service Deployment

Regulation Service Communications



ERCOT to QSEs providing Regulation:

- Control Signals
- Every 4 seconds
- Over ICCP data link or SCADA

QSEs to ERCOT:

- AS Resource Responsibility
- Status indicators for Regulation Up and Regulation Down
- Participation Factor of each Resource providing Regulation



Regulation Service Deployment

- It does not change the SCED base point signal. LFC base point is separate from SCED base point.
- LFC updates Regulation deployment based on calculated ACE and previous Regulation deployment.
- LFC requires participation factors for each resource to calculate and monitor base point deviation.

Responsive Reserve Service Deployment

Responsive Reserve Overview

ERCOT may deploy Responsive Reserve:

- When the goal of restoring frequency to normal within 10 minutes exceeds the Reg-Up ramping capability
- When there is insufficient capacity available for SCED to dispatch

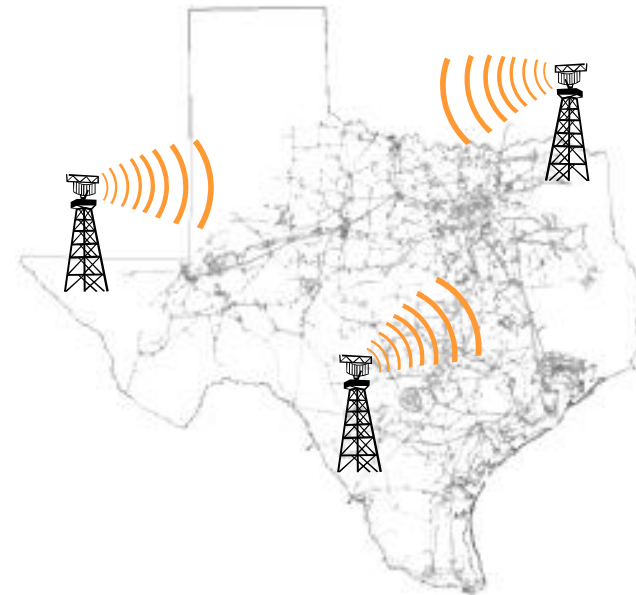

Responsive Reserve Deployment

Responsive Reserve Communications



ERCOT to QSEs providing Responsive Reserve:

- Control Signals
- Every 4 seconds
- Over ICCP data link or SCADA for Generation and Controllable Load Resources
- XML for non-Controllable Load Resources

QSEs to ERCOT:

- AS Resource Responsibility
- AS Schedule by Resource

For Responsive Reserve:

AS Schedule = AS Resource Responsibility – AS Deployment



Responsive Reserve Deployment

Responsive Reserve Deployment

ERCOT allocates deployment proportionally among QSEs providing Responsive Reserve through LFC.



QSE adjusts each Resource's AS Schedule to reflect the Responsive Reserve deployment.

SCED is triggered and energy from Resource is dispatched by SCED.



Resource Limit Adjustment during AS Deployments.

When AS is deployed, SCED will receive adjusted HASL.

Below example shows the case when RRS is deployed from a resource.

NOTE: When RRS is deployed, Emergency Ramp Rates are used.

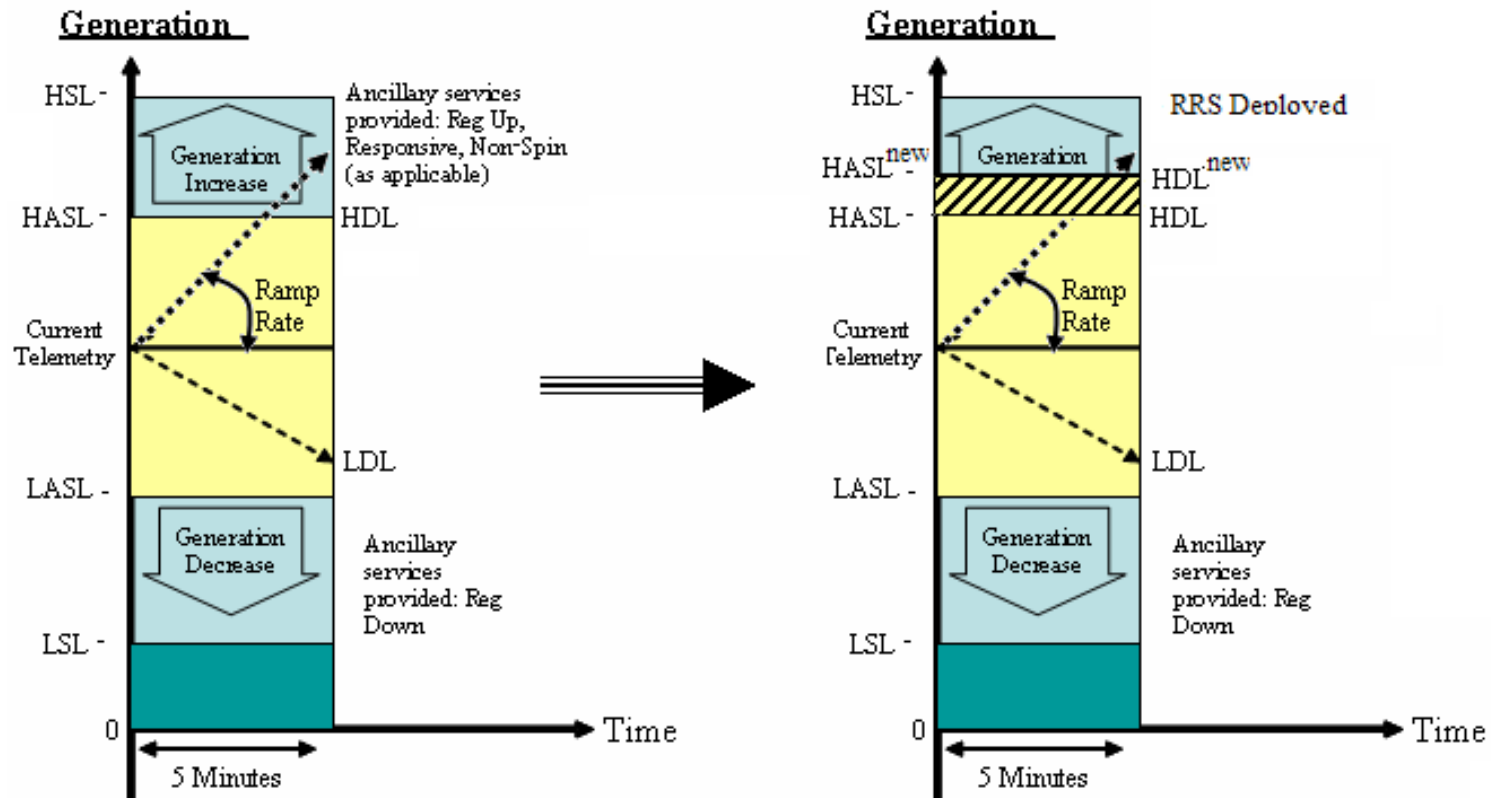

Non-Spinning Reserve

Non-Spinning Reserve Deployment

Resource	Dispatch	Requirements	Misc.
Off-Line Generation Resource	-XML message for deployment -SCED dispatches energy	25 minutes deadline to reflect resource status online and telemetered generation at LSL	Base Points include Non-Spin and other energy dispatched as a result of SCED
Non-Controllable Load Resource	XML message Operator Dispatch Instruction	<p>Traditional Non-spin is supplied by Off-line Generation Resources that can be synchronized and ramped to a specific output level within 30 minutes. Deployment is communicated through Operator Dispatch Instruction.</p>	
On-Line Generation Resource and Controllable Load Resources	-XML message -QSE AS Schedule Decreased -SCED dispatches energy		include Non-Spin and other energy dispatched as a result of SCED

Non-Spinning Reserve

Non-Spinning Reserve Deployment

Resource	Dispatch	Requirements	Misc.
Non-Controllable Load Resource	<ul style="list-style-type: none"> -XML message -Operator Dispatch Instruction 	30 minutes to respond between 95% and 150% of MW deployment	
Off-Line Generation Resource	<ul style="list-style-type: none"> -XML message for deployment -SCED dispatches energy 	25 minutes deadline to reflect resource status online and telemetered generation at LSL	Base Points include Non-Spin energy and other energy dispatched as a result of SCED
On-Line Generation Resource and Controllable Load Resources	<ul style="list-style-type: none"> -XML message -QSE AS Schedule Decreased -SCED dispatches energy 	Within 20 minutes update AS Schedule.	Base Points include Non-Spin energy and other energy dispatched as a result of SCED

Non-Spinning Reserve

Non-Spinning Reserve Deployment

Resource	Dispatch	Requirements	Misc.
On-Line Generation Resource and Controllable Load Resources	<ul style="list-style-type: none"> -XML message -QSE AS Schedule Decreased -SCED Dispatches energy 	Within 20 minutes update AS Schedule.	Base Points include Non-Spin and other energy dispatched as a result of SCED
Non-Controllable Load Resource	<ul style="list-style-type: none"> -XML message -Operator Dis 		
Off-Line Generation Resource	<ul style="list-style-type: none"> -XML message for deployment -SCED dispatches energy 	resource status online and telemetered generation at LSL	

Non-Spinning Reserves may also be provided from On-Line Resources and deployed through SCED

Non-Spin Deployment Example

- $HDL/LDL = RT\ Gen \ +/- \ (RR*5)$
- $Sum\ HASL/LASL = Sum\ HSL/LSL \ +/- \ Sum\ AS$
- $Sum\ HDL \ approaching\ Sum\ HASL$

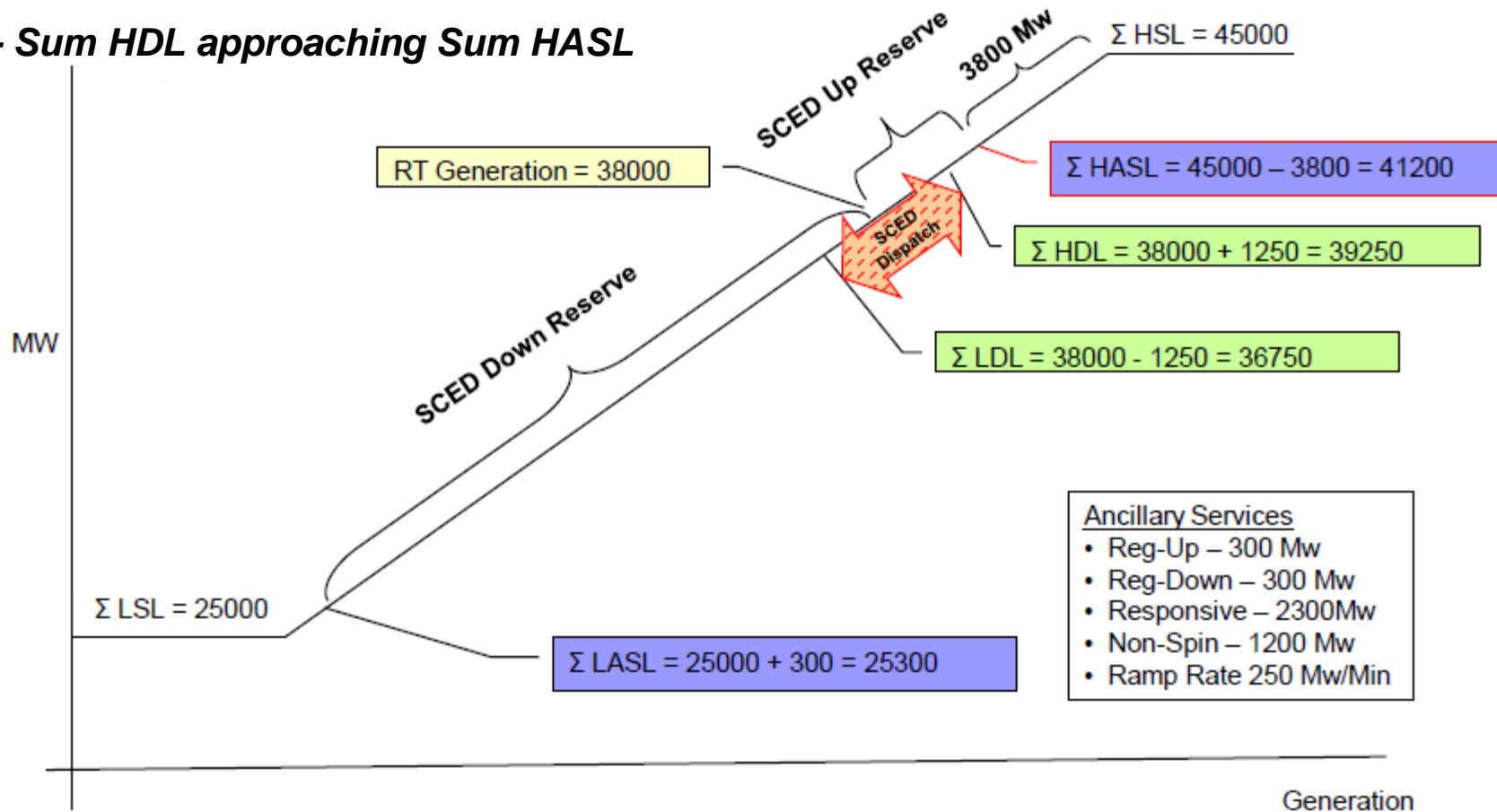

Non-Spin Deployment Example

- NSRS Deployed
- AS Schedules Reduced
- HASL modified by change in AS Schedules
- SCED able to deploy energy

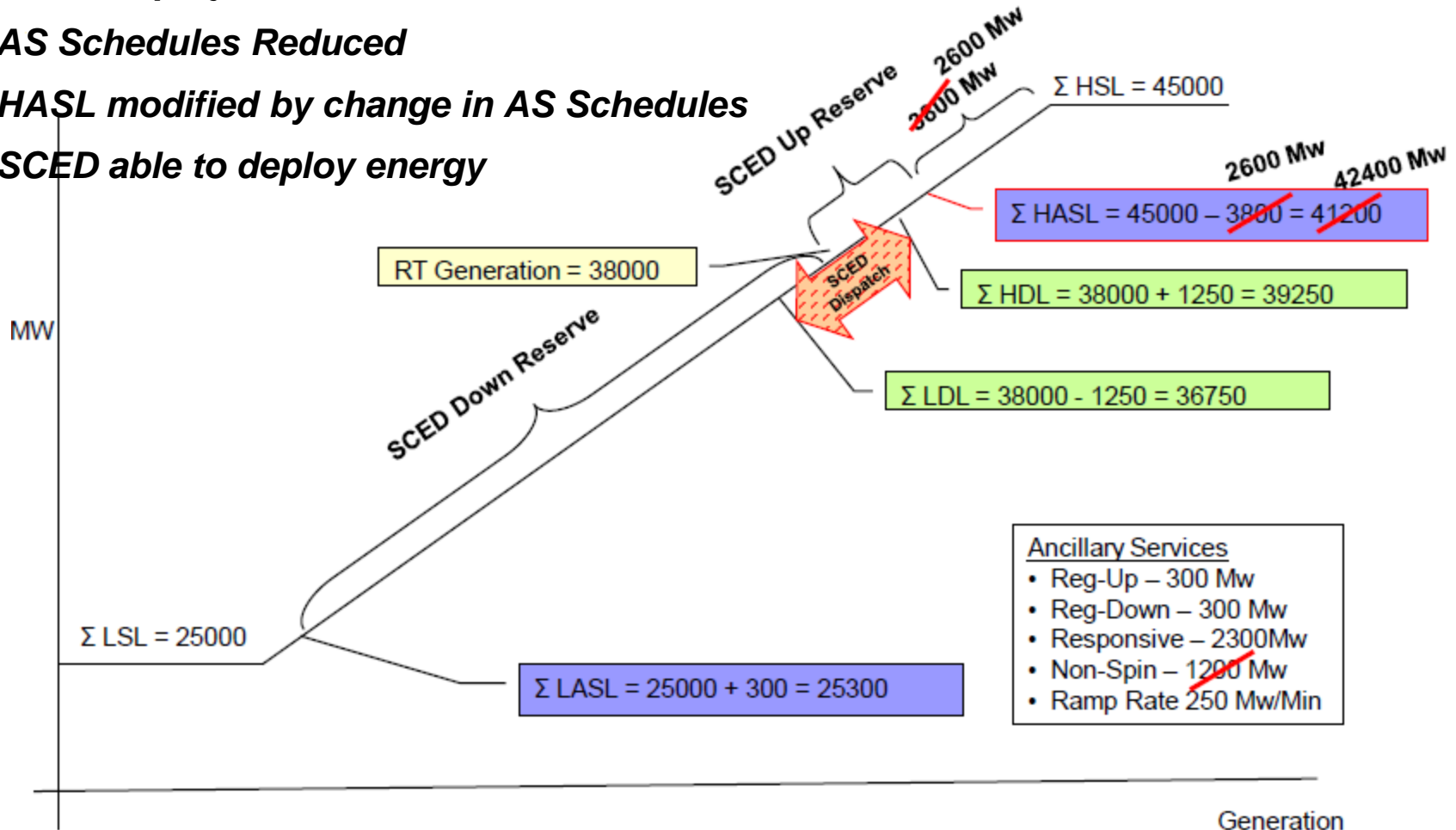

II. Overview of System Implementation

C. Implementation: Testing Overview

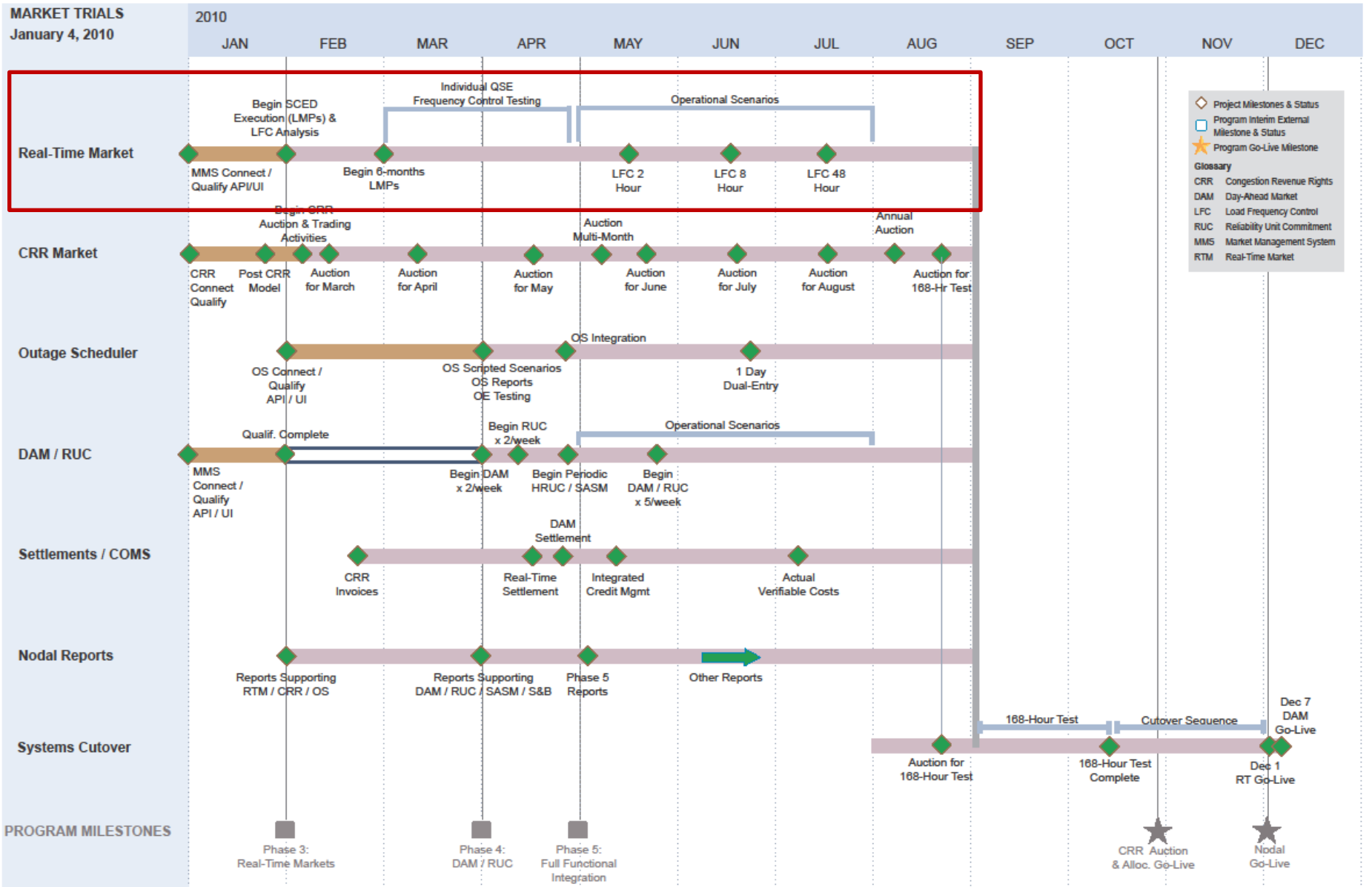

Implementation: Testing Overview

Testing

- Feb – SCED execution begins
- March 1 – 6 Months of LMP
- March-April – Individual LFC Testing for QSE with A/S
- May – 2 Hour Load Frequency Control closed loop test
- June – 8 Hour Load Frequency Control closed loop test
- July – 48 hour Load Frequency Control closed loop test

Available Resources, Documentation, Sources

- [Market Trials Handbook for Real-Time](#)
- [Explanation of Market Submission items](#) – describes transactions and submissions inputs to the market system
- [MMS Real-Time Requirements](#)
- [MMS White Papers](#) – Special topics for SCED such as RRS deployment
- [System Implementation Guide whitepapers](#) – Special topics such as combined cycle dispatch

General:

- [Web Services interface specification](#)
- [Market Manager User Interface user guide](#)

Settlements Workshops Schedule

Settlements Workshops 2010 – Tentative

Workshop Type	Date(s)	Location
RUC/Real Time	February 23	Met Center, Austin
RUC/Real Time	March 9	Garland
RUC/Real Time	March 23	Calpine, Houston