

Texas Regional Entity Report

HR & Governance Committee
Meeting

December 11, 2007

First 6 Months of Operation

- Staffing
- Auditor training
 - Need for continuous improvement
- Ongoing development of processes and procedural changes
 - Handling of violations of NERC Reliability Standards and imposition of penalties
 - NERC Policies and Procedures
 - Audit guidelines
- Organization registration

Potential Challenges in 2008

- Staffing
- Completing scheduled audits
- Auditor training and continuous improvement
- Developing a budget and staff that adequately addresses requirements
- Increasing and unknown workload
 - Events requiring Compliance Investigations
 - Appeals of violations and/or penalties
- Addressing remaining Organization Registration issues
- Relationship with the ERCOT ISO
- Functional vs. Structural separation from the ERCOT ISO

Texas RE Staffing

- 22 budgeted positions in 2007
 - 16 positions filled
 - 6 positions vacant but posted
 - Director of Compliance
 - Executive Assistant
 - Sr. Financial Analyst
 - Standards Development Coordinator
 - Compliance Engineer/Analyst (2)
- 3 additional positions in 2008 budget
 - Sr. Paralegal
 - Compliance Administrator
 - Document Coordinator
- Staffing Adequacy

Texas RE Organization Chart

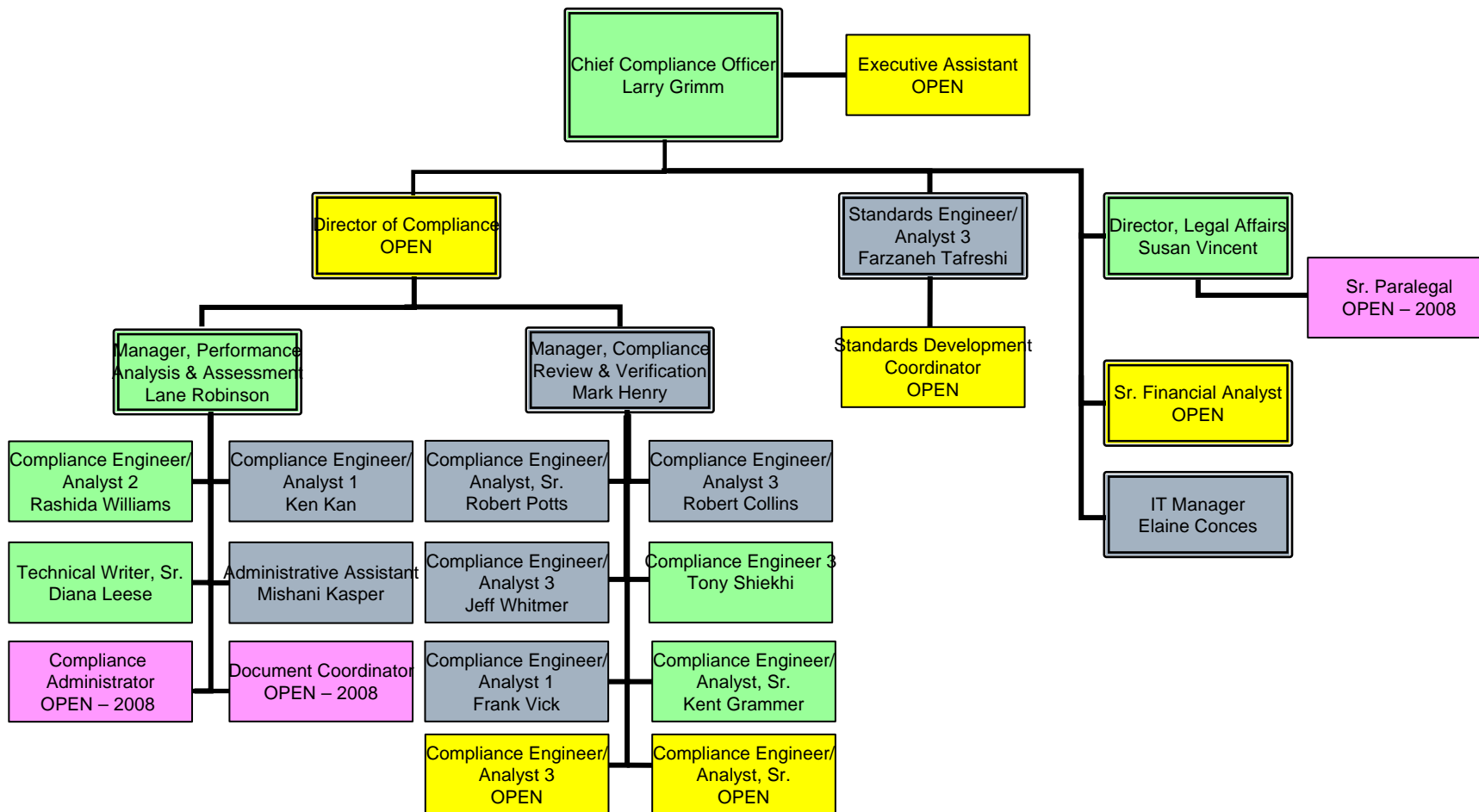

Staffing Concerns

- Aging workforce and lack of skilled workers – Concern throughout the industry (NERC Reliability Issue Survey)
 - Rated by survey respondents as the most important issue affecting the reliability of the bulk power system
 - Considered by many to be a reliability risk
- Recruiting difficulties for power system engineers
 - Many entities competing for the same resources – FERC, NERC, ISOs, RTOs, Market Participants, Regional Entities, Consultants.....
 - Many universities no longer offer a curriculum in power systems engineering
 - Competitive salary – attracting & retaining qualified staff
- Office space

Increasing Workload

- 228 functions currently registered in the ERCOT Region
- Purchasing-Selling Entity (PSE) Registration
 - Initially, registration notices sent to 33 entities
- Likely increase in Joint Registration relationships
 - TOP Function – ERCOT ISO & Transmission Owners
 - GOP Function – QSEs registered as Generator Operators & Generator Owners
 - Increases the number of entities to be monitored and compliance enforcement becomes more complex, especially compliance audits
- Increasing number of Reliability Standards – currently 83 FERC-approved; likely to be >150
- Unknowns
 - Compliance Investigations?
 - Appeals?
- More rigorous compliance monitoring and enforcement requirements

2008 Audits

- 36 individual audits currently scheduled
 - 16 table top
 - 20 on-site
- The number of audits may increase as additional Joint Registration relationships are established
- NERC “prefers” that 4 RE staff participate on each audit
 - Texas RE plans to use 3 to 4 staff on audits depending on each entity’s registration and size
 - Currently developing estimates of staff-hours per audit on average based on current known requirements
 - Planning and preparation
 - Actual audit
 - Report & violation notice generation
 - Follow-up

Relationships

- Market Participants – Appears to be generally good
- ERCOT ISO – Appears to be as good as can be expected but somewhat strained at times
- PUCT – Have met Pam Whittington, new Division Director of the Oversight and Enforcement Division
 - Will work with her and other PUCT Staff to revise ERCOT Compliance Process
 - Have worked with PUCT Legal Staff on processes and procedures
- NERC – Continuous communication with NERC Staff; NERC and the Regions are all working closely and well together
 - Regional Entity Compliance Managers
 - Regional Entity Management Group
- FERC – Appears good, but not much interaction with FERC Staff to date
 - Sense that FERC is keeping an eye on independence between ERCOT ISO and Texas RE
 - Attending and/or participating in Technical Conferences

Texas RE Governance Relationship

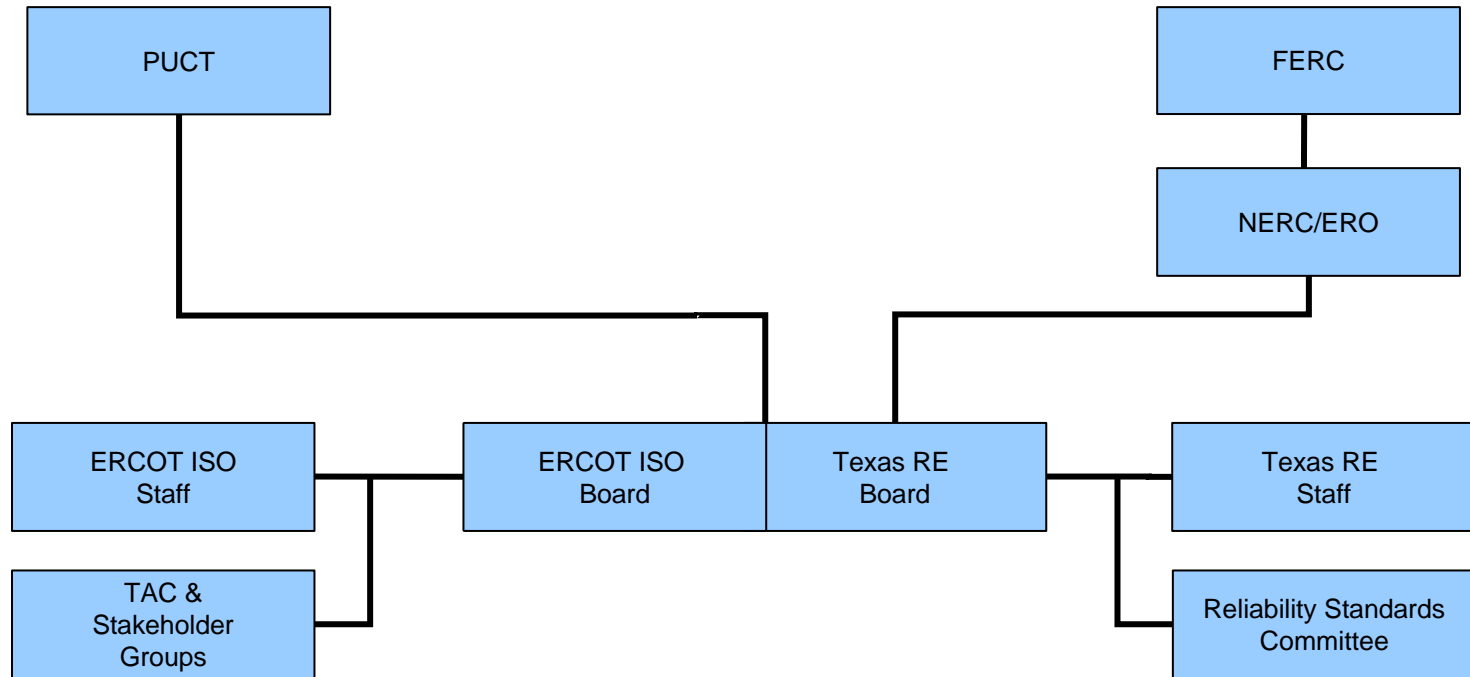

Compliance Reporting

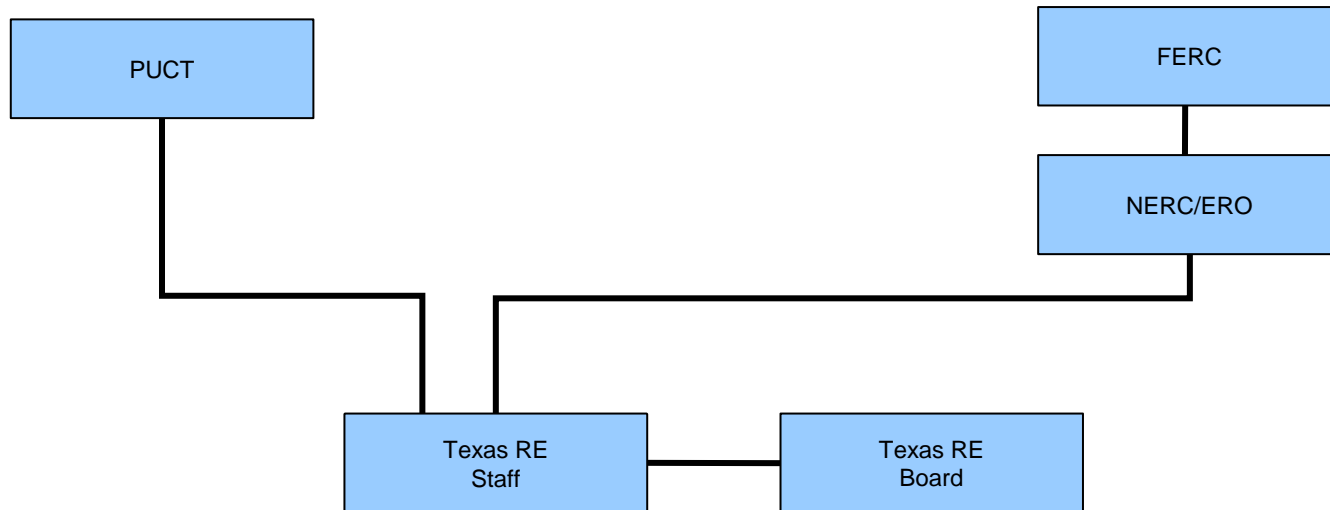

Texas RE Website & Domain

- New @TexasRE.org email addresses
 - Previous @ercot.com addresses still work
- Contracted with a local designer to design Texas RE Website and Logo
 - Planned design completion – end of December or early January
- Helps to reflect greater independence from ERCOT